

## FEATURES

- 750 - 1250 MHz
- SMA Connectorized
- Ultra High Isolation, 107 dB Typical
- High Intercept Performance
- 6.4 mA at +5 VDC



MODEL NO.  
DSW16282

Switch SPST

SPST

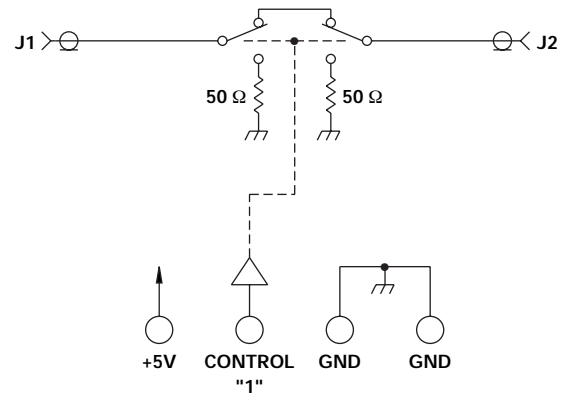
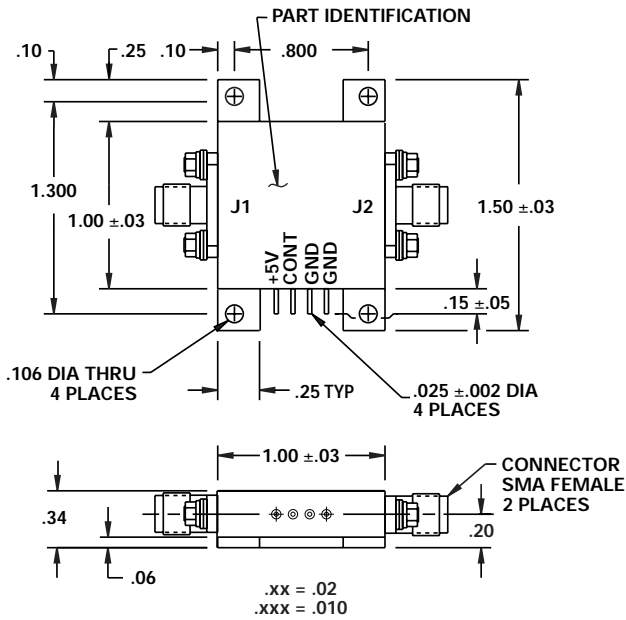

## GUARANTEED PERFORMANCE

Parameter	Min	Typ	Max	Units	Conditions
Operating Frequency	750		1250	MHz	
DC Current		6.4	12	mA	At +5 VDC Supply
Control Type		TTL			Logic "1" = Thru
Control Current		0	±10	µA	VIH = +2.7 V
		0	±10	µA	VIL = +0.5 V
Insertion Loss		1.2	1.5	dB	750 - 1000 MHz
		1.3	2.0	dB	1000 - 1250 MHz
Isolation	80	107		dB	
VSWR		1.12/1	1.3/1		
		1.08/1	1.5/1		
Impedance		50		OHMS	
Switching Speed		.2	3.0	µSec	50% TTL - 90% / 10% RF
Transition (Rise/Fall) Time		.015		µSec	10%/90% or 90%/10% RF
Switching (Video) Transients		40.0		mV	Peak Value
Intercept Points		+70		dBm	750 / 350 MHz
		+50		dBm	375 / 350 MHz
RF Power		+24	+17	dBm	0.1 dB Compression
		+27	+27	dBm	At 750 MHz
Operating Temperature	-20	+25	+50	°C	TA

