

## FEATURES

- Automatically restarts microprocessor after power failure
- Maintains reset for 350 ms after  $V_{CC}$  returns to an in-tolerance condition
- Accurate 5%, 10% or 15% microprocessor 5V power supply monitoring
- Reduces need for discrete components
- Precision temperature-compensated voltage reference and voltage sensor
- Low-cost TO-92 package or surface mount SOT-223 package
- Internal 5 k $\Omega$  pull-up resistor
- Compatible with Motorola 68XXX series and HC16 Microprocessors
- Operating temperature of -40°C to +85°C

## PIN ASSIGNMENT

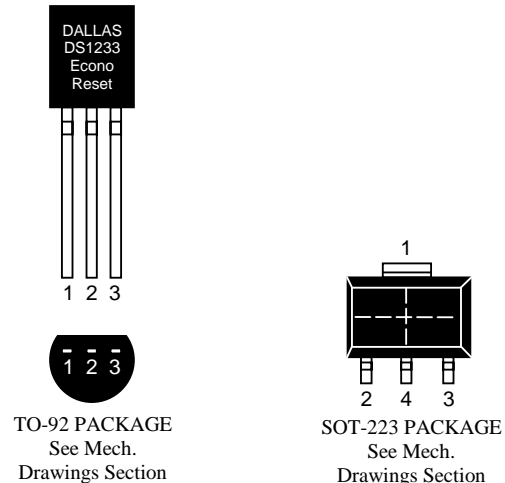

## PIN DESCRIPTION

PIN 1	$\overline{\text{GROUND}}$
PIN 2	$\overline{\text{RESET}}$
PIN 3	$V_{CC}$
PIN 4	$\overline{\text{GROUND}}$ (SOT-223 ONLY)

## DESCRIPTION

The DS1233D EconoReset uses a precision temperature-compensated reference and comparator circuit to monitor the status of the power supply ( $V_{CC}$ ). When an out-of-tolerance condition is detected, an internal power-fail signal is generated which forces reset to the active state. When  $V_{CC}$  returns to an in-tolerance condition, the reset signal is kept in the active state for approximately 350 ms to allow the power supply and processor to stabilize.

## OPERATION - POWER MONITOR

The DS1233D provides the functions of detecting out-of-tolerance power supply conditions and warning a processor-based system of impending power failure. When  $V_{CC}$  is detected as out of tolerance as defined by the tolerance of the part selected, the  $\overline{\text{RST}}$  signal is asserted. On power-up,  $\overline{\text{RST}}$  is kept active for approximately 350 ms after the power supply has reached the selected tolerance. This allows the power supply and microprocessor to stabilize before  $\overline{\text{RST}}$  is released.

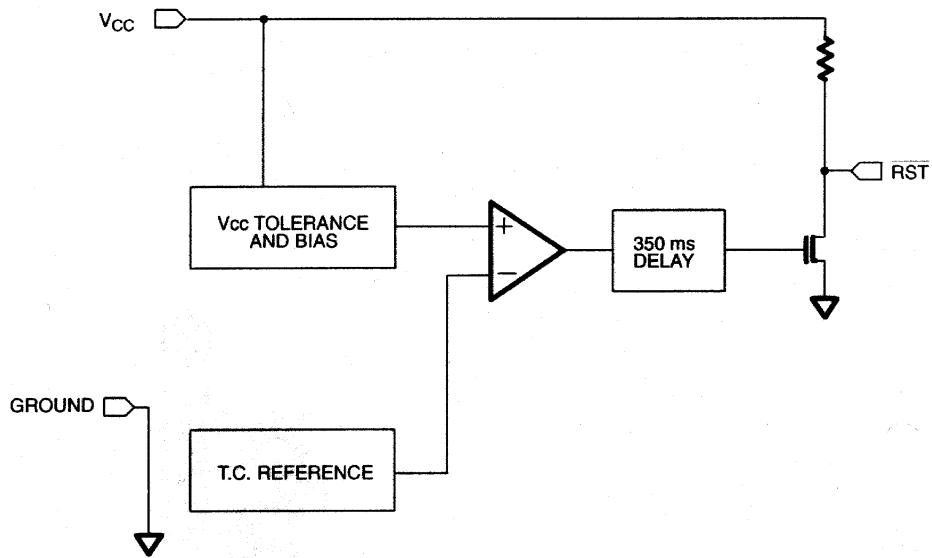
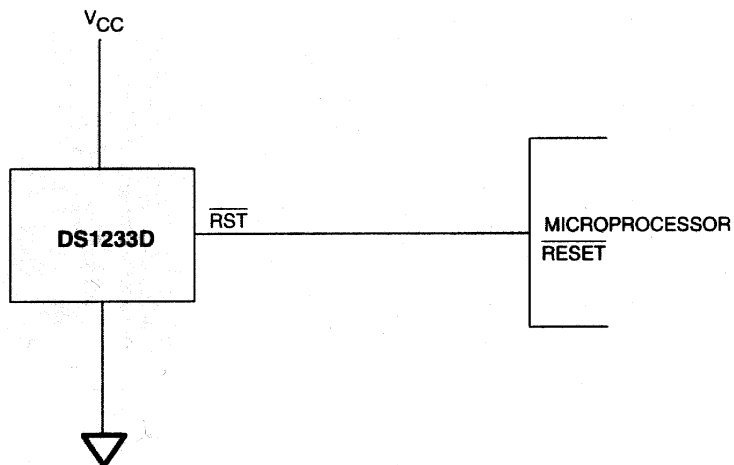
**BLOCK DIAGRAM Figure 1****APPLICATION EXAMPLE Figure 2**

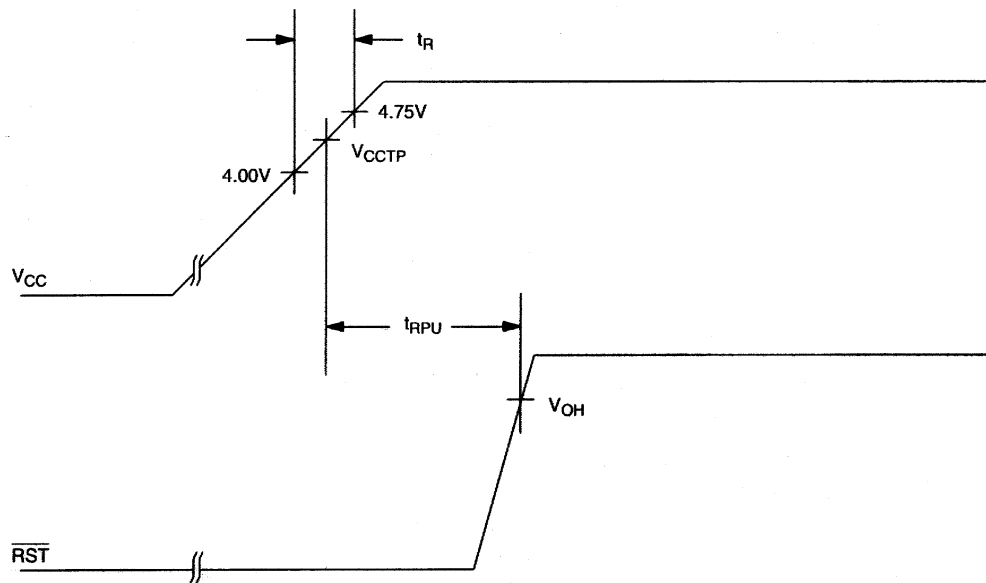
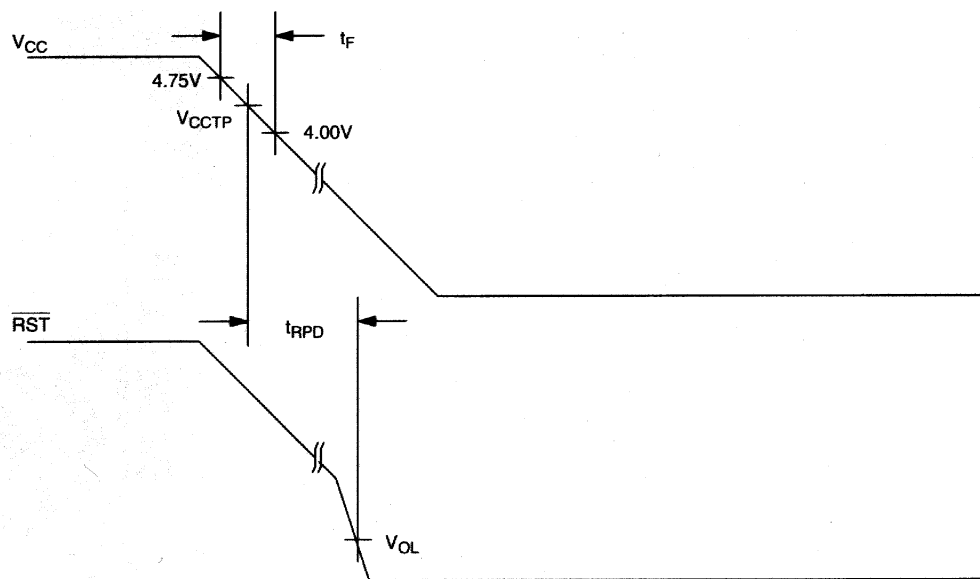
**POWER UP Figure 3****POWER DOWN Figure 4**

**ABSOLUTE MAXIMUM RATINGS\***

Voltage on V <sub>CC</sub> Pin Relative to Ground	-0.5V to +7.0V
Voltage on I/O Relative to Ground	-0.5V to V <sub>CC</sub> +0.5V
Operating Temperature	-40°C to +85°C
Storage Temperature	-55°C to +125°C
Soldering Temperature	260°C for 10 seconds

\* This is a stress rating only and functional operation of the device at these or any other conditions above those indicated in the operation sections of this specification is not implied. Exposure to absolute maximum rating conditions for extended periods of time may affect reliability.

**RECOMMENDED DC OPERATING CONDITIONS** (-40°C to +85°C)

PARAMETER	SYMBOL	MIN	TYP	MAX	UNITS	NOTES
Supply Voltage	V <sub>CC</sub>	1.2	5.0	5.5	V	1

**DC ELECTRICAL CHARACTERISTICS** (-40°C to +85°C; V<sub>DD</sub>=5V ± 10%)

PARAMETER	SYMBOL	MIN	TYP	MAX	UNITS	NOTES
Low Level @ $\overline{\text{RST}}$	V <sub>OL</sub>			0.4	V	1
Output Current @ 0.4V	I <sub>OL</sub>	+8			mA	2
Operating Current	I <sub>CC</sub>			50	μA	
V <sub>CC</sub> Trip Point 5%	V <sub>CC</sub> TP1	4.5	4.625	4.74	V	1
V <sub>CC</sub> Trip Point 10%	V <sub>CC</sub> TP2	4.25	4.375	4.49	V	1
V <sub>CC</sub> Trip Point 15%	V <sub>CC</sub> TP3	4.0	4.125	4.24	V	1
Output Capacitance	C <sub>OUT</sub>			10	pF	
Internal Pull-Up Resistor	R <sub>P</sub>	3.75	5	6.25	kΩ	

**AC ELECTRICAL CHARACTERISTICS** (-40°C to +85°C; V<sub>CC</sub>=5V ± 10%)

PARAMETER	SYMBOL	MIN	TYP	MAX	UNITS	NOTES
Reset Active Time	t <sub>RST</sub>	250	350	450	ms	
V <sub>CC</sub> Detect to $\overline{\text{RST}}$	t <sub>RPD</sub>			100	ns	
V <sub>CC</sub> Slew Rate (4.75V - 4.00V)	t <sub>F</sub>	300			μs	
V <sub>CC</sub> Slew Rate (4.00V - 4.75V)	t <sub>R</sub>	0			ns	
V <sub>CC</sub> Detect to RST	t <sub>RPU</sub>	250	350	450	ms	

**NOTES:**

- All voltages are referenced to ground.
- A 1 kΩ external resistor may be required for proper operation of the microprocessor reset control circuit.

**ECONORESET SELECTION GUIDE**

		VCC TRIP POINT			PUSHBUTTON DETECT		
		MIN	TYP	MAX	MIN	TYP	MAX
<b>5V</b>	DS1233-15	4.0	4.125	4.24	2.4	-	3.3
	DS1233-10	4.25	4.375	4.49	2.4	-	3.3
	DS1233-5	4.5	4.625	4.75	2.4	-	3.3
	DS1233D-15	4.0	4.125	4.24	N/A		N/A
	DS1233D-10	4.25	4.375	4.49	N/A		N/A
	DS1233D-5	4.5	4.625	4.75	N/A		N/A
	DS1833-15	4.0	4.125	4.24	N/A		N/A
	DS1833-10	4.25	4.375	4.49	N/A		N/A
	DS1833-5	4.5	4.625	4.75	N/A		N/A
<b>3.3V</b>	DS1233A-15	2.64	2.72	2.80	1.8	-	3.0
	DS1233A-10	2.8	2.88	2.97	1.8	-	3.0