

FEATURES

- Provides necessary control for start up and shutdown of power supply from keyboard
- Holds microprocessor in check during power transients
- Halts and restarts an out-of-control microprocessor
- Monitors push button for external override
- Warns microprocessor of an impending power failure
- Converts CMOS SRAM into nonvolatile memory
- Unconditionally write-protects memory when power supply is out of tolerance
- Consumes less than 100 nA of battery current
- Controls external power switch for high current applications
- Accurate 10% power supply monitoring
- Optional 5% power supply monitoring designated DS1239-5
- Provides orderly shutdown in nonvolatile microprocessor applications
- Supplies necessary control for low-power "stop mode" in battery operate hand-held applications
- Standard 16-pin DIP or space-saving 16-pin SOIC
- Optional industrial temperature range -40°C to +85°C

PIN ASSIGNMENT

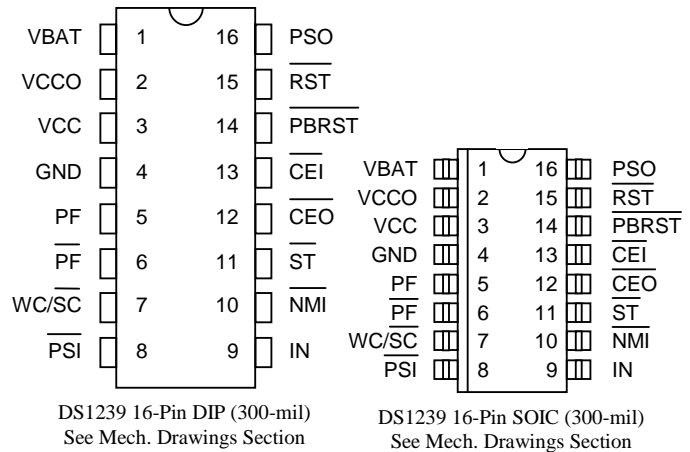

PIN DESCRIPTION

V_{BAT}	- +3 Volt Battery Input
V_{CCO}	- Switched SRAM Supply Output
V_{CC}	- +5 Volt Power Supply Input
GND	- Ground
PF	- Power Fail (Active High)
$\overline{\text{PF}}$	- Power Fail (Active Low)
$\overline{\text{WC/SC}}$	- Wake-Up Control (Sleep)
$\overline{\text{PSI}}$	- Power Supply Control Input
IN	- Early Warning Input
$\overline{\text{NMI}}$	- Non-Maskable Interrupt
$\overline{\text{ST}}$	- Strobe Input
$\overline{\text{CEO}}$	- Chip Enable Output
$\overline{\text{CEI}}$	- Chip Enable Input
$\overline{\text{PBRST}}$	- Pushbutton Reset Input
$\overline{\text{RST}}$	- Reset Output (Active low)
PSO	- Power Supply Control Outputs

DESCRIPTION

The DS1239 MicroManager provides all the necessary functions for power supply control and monitoring, reset control, and memory backup in microprocessor-based systems. Using the DS1239, an AC power switch is no longer required for microprocessor-based systems. A keyboard control system for power supply start up and shutdown is provided through the use of the Power Supply Control Input and Output. In other respects, the DS1239 is functionally identical to a DS1236 in the NMOS mode. For a complete description of the other DS1239 features, refer to the DS1236 data sheet. Pin-out of the

DS1239 is identical to the DS1236 with two exceptions. The RC and RST pins have been replaced with $\overline{\text{PSI}}$ and PSO, respectively. Other pins and functions operate exactly as the DS1236 in NMOS mode.

POWER SUPPLY CONTROL

The DS1239 facilitates the power-up and power-down sequencing of a main power supply from a keyboard or pushbutton. The Power Supply Control Input ($\overline{\text{PSI}}$) and Power Supply Control Output (PSO) are used for this purpose. Prior to establishing a voltage on V_{CC} (+5V), the $\overline{\text{PSI}}$ is internally held at a high level at all times with the V_{BAT} supply. When $\overline{\text{PSI}}$ is forced low via a keypad or other source, the PSO is connected to the V_{BAT} to provide a high level. As shown in Figure 1, this active high signal can be wired directly to an optically isolated SCR to initiate an AC to DC power-up sequence. This in turn will provide the supply voltage for V_{CC} . The timing is illustrated in Figure 2. Holding the $\overline{\text{PSI}}$ input low, the PSO output will supply a connection to the V_{BAT} pin until the V_{CC} reaches V_{BAT} , or a maximum of 500 ms. If the supply voltage on V_{CC} rises above the V_{BAT} level before the t_{PSI} timeout, the PSO pin will remain high and track the V_{CC} input. If V_{CC} does not rise above V_{BAT} before either t_{PSI} or $\overline{\text{PSI}}$ is allowed to return to a high level, the PSO output will return to tristate. Once the PSO output and V_{CC} are set at a high level, a subsequent falling edge on $\overline{\text{PSI}}$ will tristate PSO to initiate a shut down condition. The 10 microamp current supplied by the $\overline{\text{PSI}}$ pin allows the use of a 0.1 μF capacitor as a simple pushbutton debounce circuit. The battery size for this application must be selected to provide the SCR on-current for the power supply response time and is consequently application-specific.

POWER SUPPLY CONTROL Figure 1

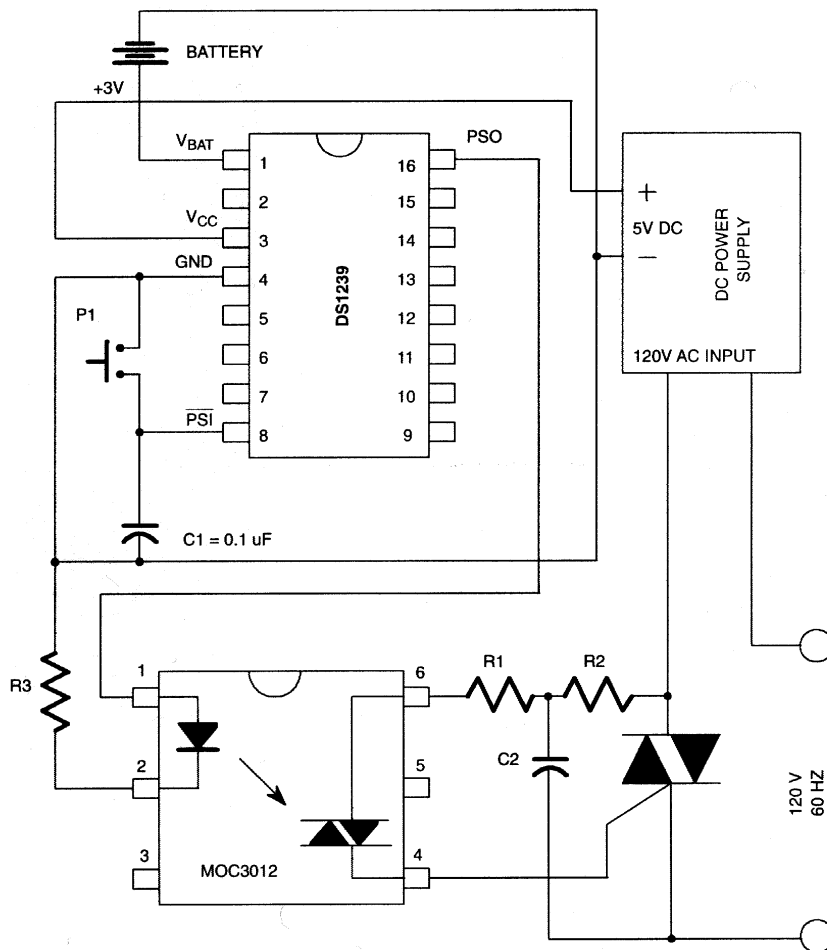

POWER SUPPLY CONTROL TIMING Figure 2

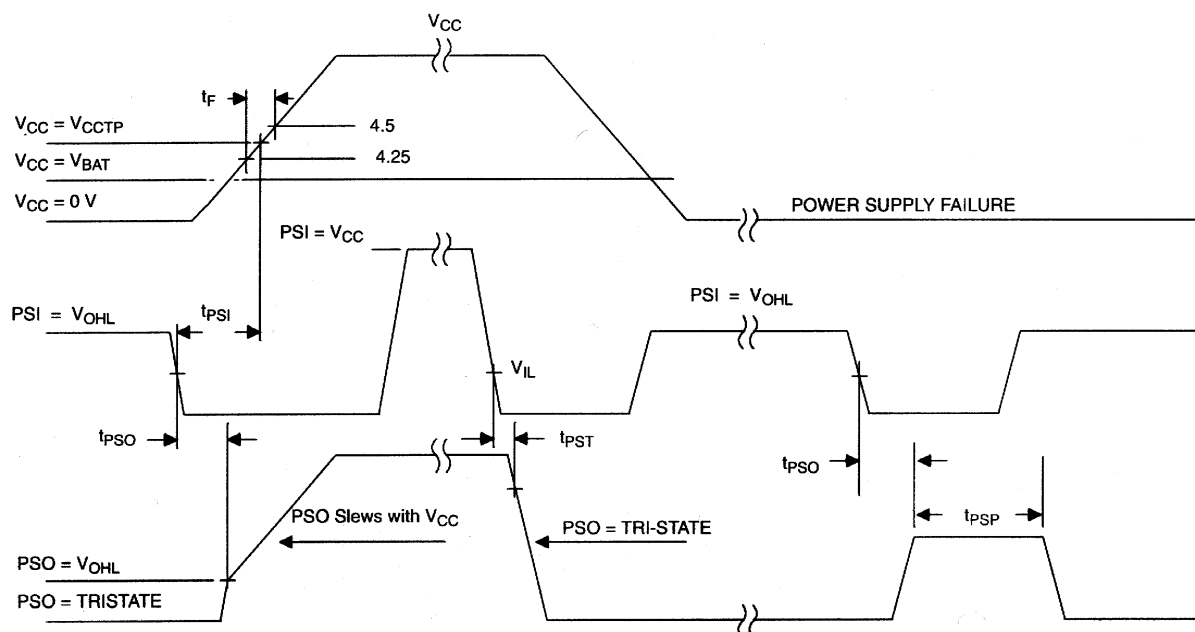

ABSOLUTE MAXIMUM RATINGS*

Voltage on V_{CC} Pin Relative to Ground	-0.5V to +7.0V
Voltage on I/O Relative to Ground	-0.5V to $V_{CC} + 0.5V$
Operating Temperature	0°C to 70°C
Operating Temperature (Industrial Version)	-40°C to +85°C
Storage Temperature	-55°C to +125°C
Soldering Temperature	260°C for 10 seconds

* This is a stress rating only and functional operation of the device at these or any other conditions above those indicated in the operation sections of this specification is not implied. Exposure to absolute maximum rating conditions for extended periods of time may affect reliability.

These specifications reflect the power supply control feature of the DS1239. For complete electrical specifications, refer to the DS1236 data sheet.

DC ELECTRICAL CHARACTERISTICS (0°C to 70°C; V_{CC} = 4.5V to 5.5V)

PARAMETER	SYMBOL	MIN	TYP	MAX	UNITS	NOTES
$\overline{\text{PSI}}$ Output Current	I_{PSI}		3		μA	
PSO Output Current	I_{PSO}	10			mA	3

AC ELECTRICAL CHARACTERISTICS (0°C to 70°C; V_{CC} = 4.5V to 5.5V)

PARAMETER	SYMBOL	MIN	TYP	MAX	UNITS	NOTES
$\overline{\text{PSI}}$ to Valid V_{CC}	t_{PSI}			200	ms	1
$\overline{\text{PSI}}$ to PSO Tri-state	t_{PST}			20	ns	
$\overline{\text{PSI}}$ to Valid PSO	t_{PSO}			100	ns	
PSO Pulse Width	t_{PSP}		200	500	ms	2

NOTES:

1. Minimum turn-on response time for AC-to-DC power supply.
2. PSO pulse width for V_{CC} held below V_{BAT} .
3. PSO will typically source 1.5 mA at 1.5V with V_{CC} = 0V, V_{BAT} = 3V.