



DS2490 USB to 1-Wire™ Bridge Chip

www.dalsemi.com

FEATURES

- Communicates at regular and Overdrive 1-Wire speeds
- Supports 12V EPROM programming and stiff 5V pullup for crypto iButton, sensors and EEPROM
- Slew rate controlled 1-Wire timing and active pullup to accommodate long lines and reduce radiation
- Programmable 1-Wire timing and driver characteristics accommodate a wide range of MicroLAN configurations at regular speed
- Smart 1-Wire protocol combines data and control information without requiring extra pins
- High-speed 12 Mbps USB interface
- Integrated USB-compliant transceiver
- Supports USB remote wakeup to resume a suspended host system

PIN ASSIGNMENT

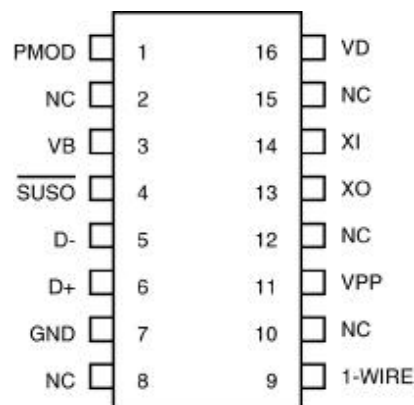

16-Pin SOIC
300-Mil

ORDERING INFORMATION

DS2490S 16-Pin SOIC

DESCRIPTION

The DS2490 is a bridge chip that enables communication between the Universal Serial Bus (USB) and a 1-Wire bus. It provides regular, overdrive and flexible 1-Wire communication speeds and a full-speed 12 Mbps connection to USB. USB vendor-specific commands defined in this specification are used to control the DS2490 and communicate with attached 1-Wire devices. A functional block diagram of the DS2490 is shown in Figure 1.

SIGNAL SUMMARY Table 1

SIGNAL NAME	TYPE	FUNCTION
VD	PWR	Power supply input for digital and 1-Wire functions. Range: 5.0±10%
VPP	PWR	Power supply input for 1-Wire EPROM programming. Range: 12V±0.25V
VB	PWR	Power supply input for USB functions. Range: 3.3V±10% supply regulated from USB supplied VBUS.
D+	I/O	USB data - non-inverted of differential data pair.
D-	I/O	USB data - inverted signal of differential data pair.
1-Wire	I/O	1-Wire Input/Output.
PMOD	I	Reserved for future use. Must be tied to GND.
$\overline{\text{SUSO}}$	O	Suspend Output - buffered USB suspend state output from USB device controller. When LOW the USB is in an active non-suspended state, when HIGH the USB has entered a suspended state. This is an open drain output and requires an external pullup.
XI	I	Crystal input. Use a 12.0 MHz, fundamental mode, parallel resonant crystal. A 12.0 MHz CMOS clock source may also be used.
XO	O	Crystal output. Connect to other side of crystal 1 if used.
GND	PWR	Ground reference and ground return for 1-Wire bus.
NC		No connect. For factory use or reserved, do not connect to these pins.

RELATED DOCUMENTS

This specification uses terms from and references or complies with the *Universal Serial Bus Specification*, which may be obtained from the USB Implementers Forum web site: www.usb.org. The USB specification is considered to be part of the DS2490 specification.

This specification uses several terms and acronyms associated with Dallas Semiconductor 1-Wire products and technologies. For a detailed description of *iButton* technology and terms download the *Book of iButton Standards* from the Dallas Semiconductor *iButton* web site: www.ibutton.com.

DOCUMENT ORGANIZATION

The remainder of this document is organized into the following major sections:

SECTION	Summary
OVERVIEW	Device functional summary and application examples
1-WIRE I/F CONTROLLER	Edge control and timing diagrams of 1-Wire signals
USB COMMUNICATION	Configuration model, core and vendor-specific command summaries
MODE COMMANDS	Commands used to configure 1-Wire interface operational characteristics
CONTROL COMMANDS	Commands used to control 1-Wire communication command processing
COMMUNICATION COMMANDS	Commands used to communicate with an attached 1-Wire device
DEVICE FEEDBACK	Technique to obtain device status information

USB TRANSCEIVER	Transceiver connection requirements
OSCILLATOR	Oscillator connection requirements
SUSPEND OUTPUT	$\overline{\text{SUSO}}$ signal operation and purpose
ELECTRICAL CHARACTERISTICS	DC and AC specifications
APPLICATION INFORMATION	HW and SW application information
APPENDIX 1	CONTROL COMMANDS – USB setup packet encoding
APPENDIX 2	COMMUNICATION COMMANDS - USB setup packet encoding
APPENDIX 3	MODE COMMANDS - USB setup packet encoding
APPENDIX 4	USB command and command type constant codes

OVERVIEW

The DS2490 directly interfaces a USB port to a 1-Wire bus. As shown in Figure 1, the DS2490 incorporates a USB physical interface, a USB device controller coupled with a 1-Wire specific USB function core, and a 1-Wire bus interface controller. The 1-Wire interface controller shapes the slopes of the 1-Wire wave-forms, applies programming pulses or strong pullup to 5V, and reads the 1-Wire bus using a non-TTL threshold to maximize the noise margin for best performance on large 1-Wire MicroLAN networks. 1-Wire waveform timing is accurately controlled with a crystal-based oscillator.

The DS2490 also supports USB remote wakeup which enables the DS2490 based USB peripheral to send resume signaling to a suspended host system. If the remote wakeup function is enabled and the host system is in a suspended state, a 1-Wire device attachment will cause the DS2490 to perform a host system wakeup and allow the 1-Wire device to be serviced.

DS2490 FUNCTIONAL BLOCK DIAGRAM Figure 1

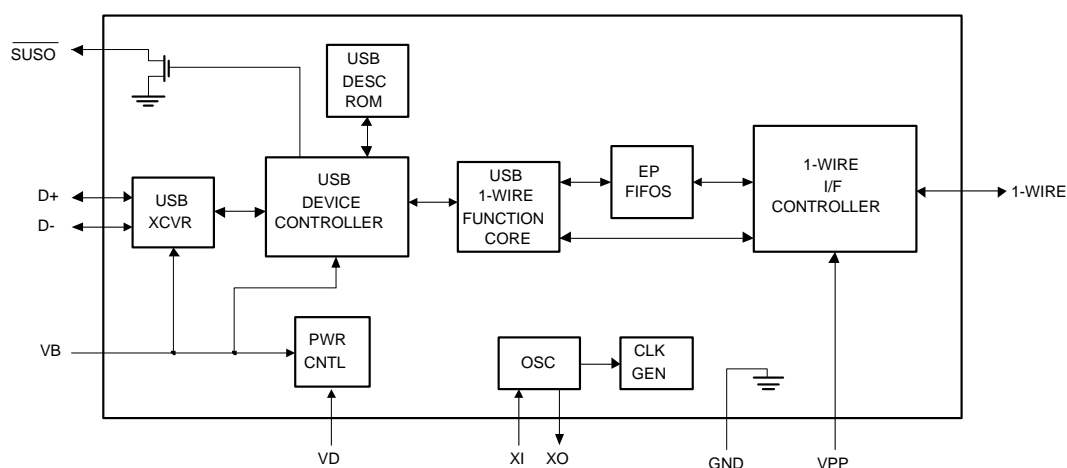

Typical application examples of the DS2490 are shown in Figure 2 (a-c). As shown in all the examples, all host control and communication with the device is accomplished over a USB communication link. A USB vendor-specific command set, as defined in this document, is used to select operational modes (MODE commands), control command processing (CONTROL commands), and communicate over the 1-Wire interface (COMMUNICATION commands). Shown in Figure 2 example (a) is a DS2490 based USB peripheral application. The peripheral function is a USB to 1-Wire adapter and provides both USB and 1-Wire I/O connections. In this example the peripheral is attached to the USB enabled host computer

either directly at a root port or through a USB HUB. The 1-Wire bus interface provided by the DS2490 supports all 1-Wire devices manufactured by Dallas Semiconductor as well as the various 1-Wire bus topologies simple multi-drop to complex MicroLAN. Example (b) and (c) in Figure 2 are variations of example (a) in which the DS2490 is embedded in the host computer or a USB HUB.

DS2490 Application Examples Figure 2

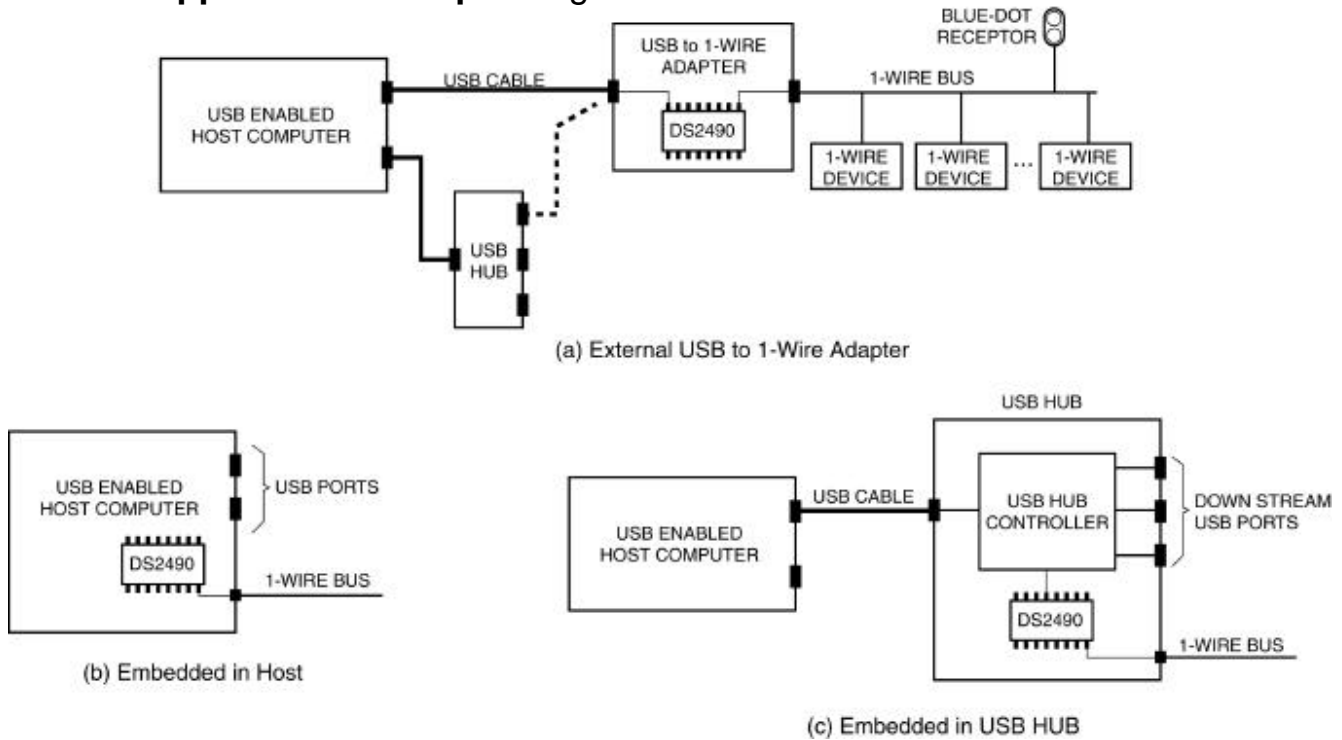

1-WIRE INTERFACE CONTROLLER

1-Wire communication commands sent to the DS2490 are ultimately processed by the 1-Wire interface controller. One of the tasks of the interface controller is to actively shape the edges of the 1-Wire communication waveforms. This speeds up the recharging of the 1-Wire bus (rising edges) and reduces ringing of long lines (falling edges). The circuitry for shaping rising edges is always active. The slew rate of falling edges is actively controlled only at flexible speed and requires the parameter for slew rate control being different from its power-on default value. See the MODE COMMANDS section for parameter control and power-on defaults.

All Rising Edges

The active pullup of the rising edges reduces the rise time on the 1-Wire bus significantly compared to a simple resistive pullup. Figure 3 shows how the DS2490 is involved in shaping a rising edge.

ACTIVE PULLUP Figure 3

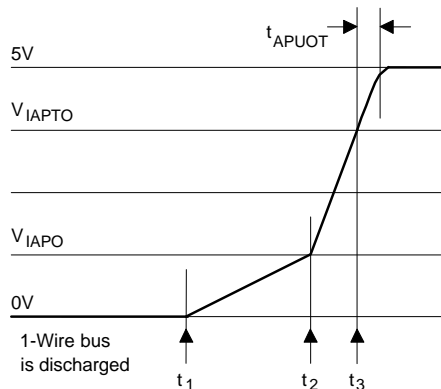

The circuit operates as follows: At t_1 the pull-down (induced by the DS2490 or a device on the bus) ends. From this point on the 1-Wire bus is pulled high by the weak pullup current I_{WEAKPU} provided by the DS2490. The slope is determined by the load on the bus and the value of the pullup current. At t_2 the voltage crosses the threshold voltage V_{IAPO} . Now the DS2490 switches over from the weak pullup current I_{WEAKPU} to the higher current I_{ACTPU} . As a consequence, the voltage on the bus now rises faster. As the voltage on the bus crosses the threshold V_{IAPTO} at t_3 , a timer is started. As long as this timer is on (t_{APUOT}), the I_{ACTPU} current will continue to flow. After the timer is expired, the DS2490 will switch back to the weak pullup current.

Falling Edges (DS2490-initiated)

Whenever the DS2490 begins pulling the 1-Wire bus low to initiate a time slot, for example, it first turns off the weak pullup current I_{WEAKPU} . Then, at regular and Overdrive speed it will generate a falling edge at a slew rate of typically $15 \text{ V}/\mu\text{s}$. This value is acceptable for short 1-Wire busses and adequate for communication at Overdrive speed. For MicroLAN networks of more than roughly 30 meters length, flexible speed should always be used. One of the parameters that is adjustable at flexible speed is the slew rate of DS2490-initiated falling edges. The effect of the slew rate control is shown in Figure 4.

SLEW RATE CONTROL Figure 4

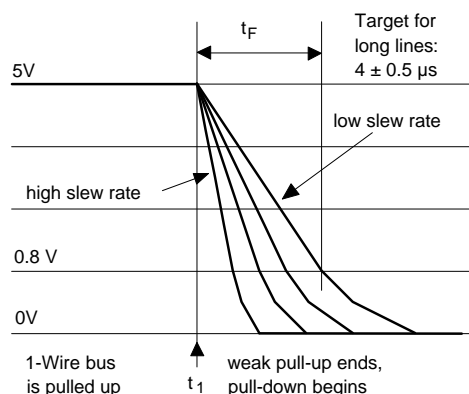

As extensive tests have shown, MicroLAN networks at a length of up to 300 meters will perform best if the fall time t_F is in the range of $4 \pm 0.5 \mu\text{s}$. This translates into a slew rate of approximately $1 \text{ V}/\mu\text{s}$. This slew rate is typically achieved by selecting a PULLDOWN SLEW RATE parameter code of 0x4 (see MODE COMMANDS). If the actual measured fall time is longer than the target value, a parameter code of 0x3 or lower should be used. If the fall time is shorter, a parameter code of 0x5 or higher should be

used. Once determined, the value code for the Pulldown Slew Rate Control parameter should be stored in the host and always be loaded into the DS2490 after a power-on or master reset cycle.

1-WIRE TIMING DIAGRAMS

This section explains the waveforms generated by the DS2490 on the 1-Wire bus in detail. First the communication wave forms such as the Reset/Presence Detect Sequence and the time slots are discussed. After that follows a detailed description of the pulse function under various conditions. The wave forms generated by the DS2490 may deviate slightly from specifications found in the “Book of DS19xx iButton Standards” or in data sheets of 1-Wire slave devices. However, the DS2490 has been designed to ensure that the timing requirements are met.

1-Wire Communication Wave Forms

One of the major features of the DS2490 is that it relieves the host from generating the timing of the 1-Wire signals and sampling the 1-Wire bus at the appropriate times. The reset/presence detect sequence is shown in Figure 5. This sequence is composed of four timing segments: the reset low time t_{RSTL} , the short/interrupt sampling offset t_{SI} , the presence detect sampling offset t_{PDT} and a delay time t_{FILL} . The timing segments t_{SI} , t_{PDT} and t_{FILL} comprise the reset high time t_{RSTH} where 1-Wire slave devices assert their presence or interrupt pulse. During this time the DS2490 pulls the 1-Wire bus high with its weak pullup current.

The values of all timing segments for all 1-Wire speed options are shown in the table. Since the reset/presence sequence is slow compared to the time slots, the values for regular and flexible speed are the same. Except for the falling edge of the presence pulse, all edges are controlled by the DS2490. The shape of the uncontrolled falling edge is determined by the capacitance of the 1-Wire bus and the number, speed and sink capability of the slave devices connected.

RESET/PRESENCE DETECT Figure 5

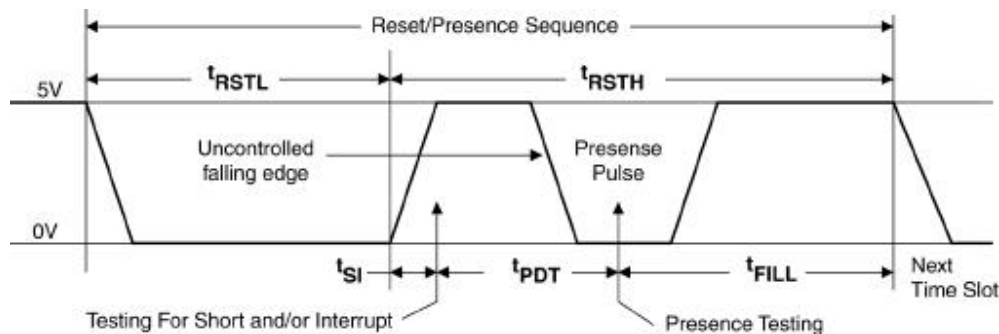

Speed	t_{RSTL}	t_{SI}	t_{PDT}	t_{FILL}	t_{RSTH}
Regular	512 μ s	8 μ s	64 μ s	512 μ s	584 μ s
Overdrive	64 μ s	2 μ s	8 μ s	64 μ s	74 μ s
Flexible	512 μ s	8 μ s	64 μ s	512 μ s	584 μ s

Upon executing a 1-WIRE RESET command (see COMMUNICATION COMMANDS), the DS2490 pulls the 1-Wire bus low for t_{RSTL} and then lets it go back to 5V. The DS2490 will now wait for the short/interrupt sampling offset t_{SI} to expire and then test the voltage on the 1-Wire bus to determine if there is a short or an interrupt signal. If there is no short or interrupt (as shown in the picture), the

DS2490 will wait for t_{PDT} and test the voltage on the 1-Wire bus for a presence pulse. Regardless of the result of the presence test, the DS2490 will then wait for t_{FILL} to expire and then send the command response byte to the host.

If the test for interrupt or short reveals a logic 0, the DS2490 will wait for 4096 μ s and then test the 1-Wire bus again. If a logic 0 is detected, the 1-Wire bus is shorted and the DS2490 feedback response for the 1-WIRE RESET Communication Command will indicate a short detection. If a logic 1 is detected, the device will wait for t_{FILL} to expire, after which it will load the feedback response value for the 1-WIRE RESET command with an Alarming Presence Pulse detect value. No additional testing for a presence pulse will be done. The DS2490 will perform the short/interrupt testing as described also at Overdrive speed, although interrupt signaling is only defined for regular speed.

A Write-1 and Read Data time slot is comprised of the segments t_{LOW1} , t_{DSO} and t_{HIGH1} . During Write-1 time slots, after the Write-1 low time t_{LOW1} is over, the DS2490 waits for the duration of the data sample offset and then samples the voltage at the 1-Wire bus to read the response. After this, the waiting time t_{HIGH1} must expire before the time slot is complete. A Write-0 time slot only consists of the two segments t_{LOW0} and t_{RECO} .

If the network is large or heavily loaded, flexible speed should be selected and the Write-1 low time (t_{LOW1}) should be extended to more than 8 μ s to allow the 1-Wire bus to completely discharge. Since a large or heavily loaded network needs more time to recharge, it is also recommended to delay sampling the bus for reading. A higher Data Sample Offset value (t_{DSO}) will increase the voltage margin and also provide extra energy to the slave devices when generating a long series of Write-0 time slots. However, the total of $t_{LOW1} + t_{DSO}$ should not exceed 22 μ s. Otherwise the slave device responding may have stopped pulling the bus low when transmitting a logic 0.

WRITE 1 AND READ DATA TIME SLOT Figure 6

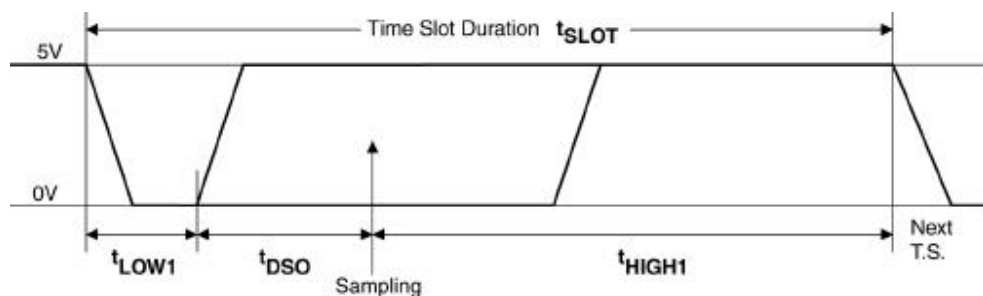

Speed	t_{LOW1}	t_{DSO}	t_{HIGH1}	t_{SLOT}
Regular	8 μ s	6 μ s	54 μ s	68 μ s
Overdrive	1 μ s	1 μ s	8 μ s	10 μ s
Flexible*	8 to 15 μ s	3 to 10 μ s	54 μ s	65 to 79 μ s

*Power-up defaults for Flexible speed: $t_{LOW1}=12\mu$ s, $t_{DSO}=7\mu$ s

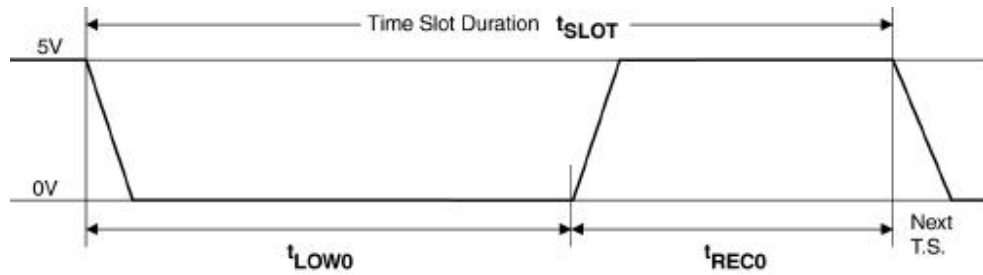
WRITE 0 TIME SLOT Figure 7

Speed	t_{LOW0}	t_{REC0}	t_{SLOT}
Regular	62 μ s	6 μ s	68 μ s
Overdrive	7 μ s	3 μ s	10 μ s
Flexible	62 μ s	3 to 10 μ s	65 to 72 μ s

***Power-up defaults for Flexible speed: $t_{REC0}=7\mu$ s**

Pulse Wave Forms

The PULSE Communication Command can be used to generate either a strong pullup to 5V or 12V programming pulse. The duration of the pulses are specified with the STRONG PULLUP DURATION and PROG PULSE DURATION mode registers. Figure 8 and Figure 9 show timing of the two pulse types. For predefined pulse durations, t_{SPU} and t_{PP} are known values, for semi-infinite and infinite durations these pulse times vary and depend on the characteristics of attached 1-Wire devices and/or host computer intervention. See the MODE COMMAND section for details on duration times. The processing of a PULSE command is essentially the same, regardless if a strong pullup or a programming pulse is specified. As shown in the figures, at t_1 processing of the PULSE command begins, at t_2 the “pulse” ends.

For EPROM programming, only a single slave device should be connected to the 1-Wire bus and the cable must be short, not to exceed a few meters. The slew rate of the rising and falling edge of the programming pulse (“steep slopes”) is actively controlled by DS2490 as shown in Figure 9. Do not attempt to generate a programming pulse with a non-EPROM device on the bus; this may damage the device as well as the DS2490. In addition, a correct programming pulse can only be generated if the 12V programming voltage is available at the VPP pin of the DS2490.

Certain applications may require a duration for a strong pullup or programming pulse that cannot be realized using one of the predefined values (see MODE COMMANDS section for values). Selecting infinite duration allows the host to generate pulses of any length. As a consequence, however, the host becomes responsible to actively control the duration of the pulse. Failing to do so may require a power-on reset or master reset cycle of the DS2490. For this reason, infinite duration should only be used if absolutely necessary. The HALT EXECUTION WHEN DONE or HALT EXECUTION WHEN IDLE Control commands are used to terminate an infinite duration pulse. As before, processing the command is essentially the same, regardless if it is for a strong pullup or a programming pulse.

STRONG PULLUP TO 5V, PREDEFINED DURATION Figure 8

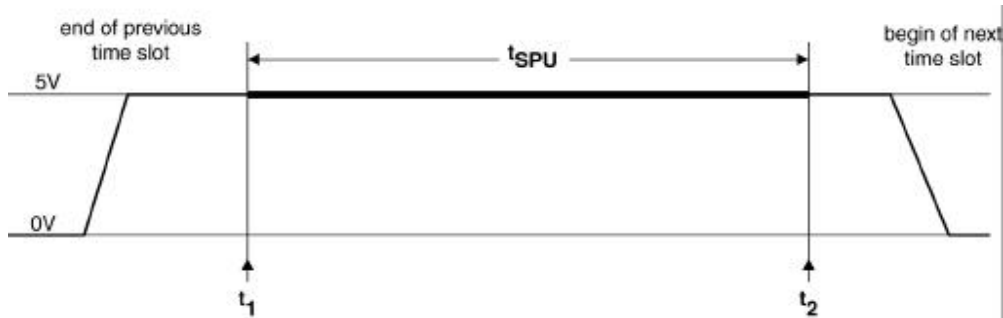

12V PROGRAMMING PULSE, PREDEFINED DURATION Figure 9

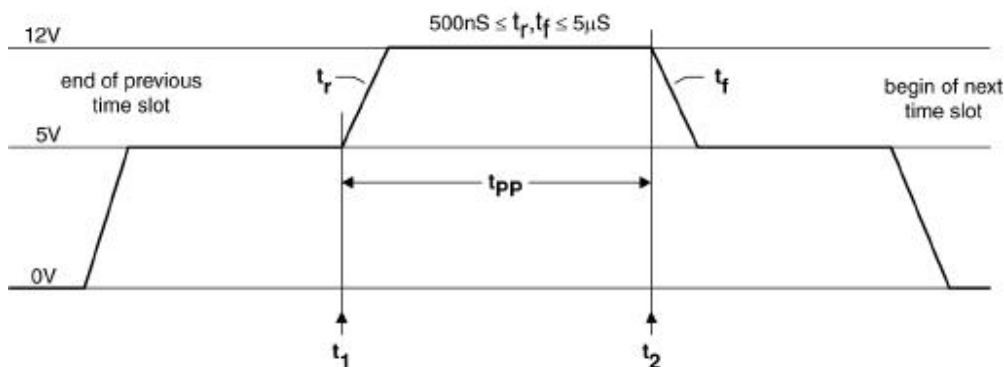

USB COMMUNICATION

Communication with the DS2490 is performed using USB standard requests, also referred to as core commands or requests in this document, and DS2490 vendor specific USB commands. All command communication with the DS2490 is performed over the default control pipe. Non-command communication, including 1-Wire device data I/O and DS2490 status information, occurs in a vendor-specific fashion over bulk and interrupt pipes. Configuration of the DS2490 USB controller is shown in Figure 10. As shown, a Dallas Semiconductor vendor-specific 1-Wire device exists with a single 1-Wire interface. The USB vendor-specific 1-Wire function of the DS2490 will be implemented and controlled by the device driver at the device level of the device class hierarchy, i.e., vendor-specific commands will be directed to the device level. Within the 1-Wire interface, four endpoints exist to control and communicate with the device. Four alternate settings of the 1-Wire interface exist which correspond to different operating modes for the endpoints. Endpoint and interface descriptions are summarized in the following paragraphs.

The DS2490 provides USB remote wakeup capability. Per the USB specification, if a device supports remote wakeup, it must also provide the ability to enable or disable the remote wakeup function. In addition, the remote wakeup feature must be disabled as the power up default or device reset state. When the remote wakeup feature is enabled, the DS2490 will send USB resume signaling to a suspended host system upon detecting a 1-Wire device attachment. It then becomes the responsibility of host system software to resume operation and to determine what servicing is required for the 1-Wire device.

USB CONFIGURATION Figure 10

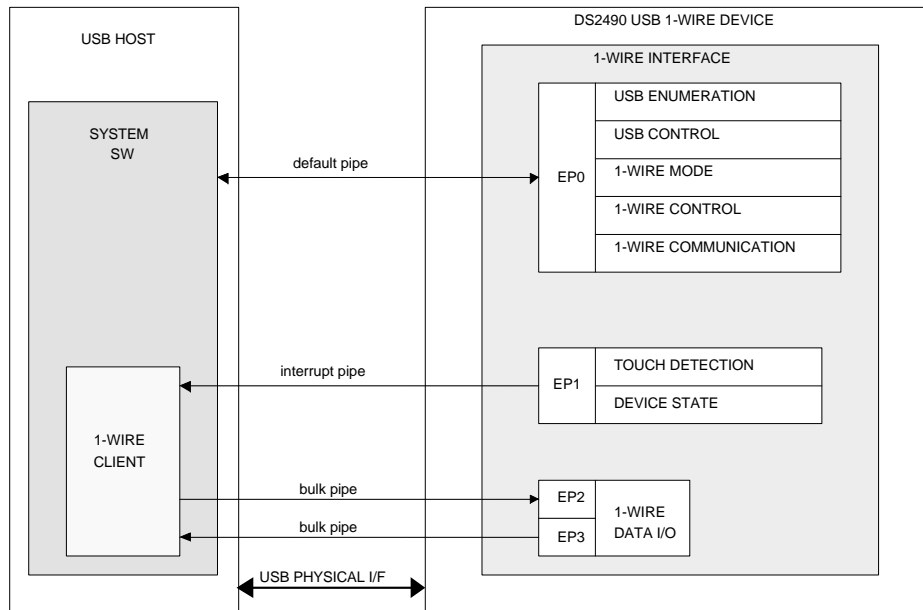

Endpoint (EP) Summary Description

EP0 is the endpoint for the bi-directional default control pipe. It is used for the USB enumeration process, USB core request communication, and all DS2490 specific command communication.

EP1 is the endpoint for an interrupt pipe (Device to Host) and is used to relay DS2490 status register data and specific command execution completion and/or error information to the host. It is also used to inform the host of 1-Wire device-attach detection. The polling period requested for EP1 is either 10 mS or 1 mS, depending on the alternate interface setting of the 1-Wire interface. The default polling period for EP1 is 10 mS.

EP2 is an endpoint for a bulk data out pipe (Data from Host) and is used to transmit 1-Wire device data from the host to the DS2490. The information received at this endpoint will be transmitted as data on the 1-Wire bus.

EP3 is an endpoint for a bulk data in pipe (Data to Host) and is used to send data received by the DS2490 from the 1-Wire bus back to the host for processing.

1-Wire Interface Summary Description

The interface is the USB collection point for the four endpoints. Four alternate settings exist for the 1-Wire interface which correspond to different operational modes for the pipes to EP1, EP2, and EP3. As shown in Table 2, the alternate settings specify different polling periods for the interrupt pipe and different maximum packet sizes for the two bulk pipes.

1-Wire Interface Alternate Setting Summary Table 2

Alt Setting	EP1 poll interval	EP2/EP3 max packet size	Alternate Setting Description
0	10mS	16 bytes	Long interrupt polling interval, small packet size for bulk pipes
1	10mS	64 bytes	Long interrupt polling interval, large packet size for bulk pipes
2	1mS	16 bytes	Short interrupt polling interval, small packet size for bulk pipes
3	1mS	64 bytes	Short interrupt polling interval, large packet size for bulk pipes

Endpoint Feature Summary Table 3

Endpoint #	Transaction Type	Direction ¹	Max. Packet Size
0	CONTROL	IN/OUT	ALT I/F-0..3: 8 bytes
1	INTERRUPT	IN	ALT I/F-0..3 32 bytes
2	BULK	OUT	ALT I/F-0: 16 bytes
			ALT I/F-1: 64 bytes
			ALT I/F-2: 16 bytes
			ALT I/F-3: 64 bytes
3	BULK	IN	ALT I/F-0: 16 bytes
			ALT I/F-1: 64 bytes
			ALT I/F-2: 16 bytes
			ALT I/F-3: 64 bytes

1. Direction in this table is in reference to the Host

USB Core Commands Table 4

Standard Device Requests	Target Element	Range	Notes
SET_ADDRESS	Device	0x01 - 0xFF	
SET_CONFIGURATION	Device	0x00 - 0x01	1
GET_CONFIGURATION	Device	0x00 - 0x01	
GET_DESCRIPTOR	Device		2
GET_INTERFACE	Interface 0	Interface 0: 0x00 - 0x03	3
SET_INTERFACE	Interface 0	Interface 0: 0x00 - 0x03	3
SET_FEATURE	Device		4
CLEAR_FEATURE	Device		4
GET_STATUS	Device, Interfaces, Endpoints 0-3		5, 6

Notes:

1. The only valid configuration values are 0 and 1 for the SET_CONFIGURATION request. Configuration value 0 corresponds to the non-configured state.
2. Only the DEVICE and CONFIGURATION descriptor types are supported for the GET_DESCRIPTOR request.
3. Interface 0 is the only valid interface value for the DS2490.
4. The only valid feature selector for the command is DEVICE_REMOTE_WAKEUP.
5. The DS2490 is intended, at a minimum, to be partially bus powered. Remote wakeup can be enabled or disabled. GET_STATUS requests to the device will return a logic 0 for the self-powered bit field and the current state value for the remote wakeup bit.
6. There is no USB core level status information defined for interfaces. The DS2490 will always return 0 value data for GET_STATUS requests to interfaces.

DS2490 Vendor Specific USB Commands

Three different vendor-specific command types exist to control and communicate with the DS2490: Control, Communication, and Mode. Control commands are used to manage various device functions including the processing of communication commands, buffer clearing, and SW reset. Communication commands are used for 1-Wire data and command I/O. Mode commands are used to establish the 1-Wire operational characteristics of the DS2490 such as slew rate, low time, strong pullup, etc. Control, Communication and Mode commands, like USB core requests, are communicated over the default control pipe at EP0. With one exception as noted below, each command and any associated parameter data are individually formatted into the 8-byte control transfer setup packet as follows:

bmRequestType	bRequest	wValue*	wIndex	wLength
Request type bit map (1 byte)	Command Type (1 byte)	Command (2 bytes)	Command Parameters (2 bytes)	0x0000 (not used)

*The one exception to **wValue** formatting is for the READ STRAIGHT Communication command. This command requires three parameter bytes which exceeds the 2-byte parameter encoding space available in the **wIndex** field. For this command only, the **wValue** field will be formatted as 1 command byte and 1 parameter byte. See the command description in Appendix 2 for details.

The bit-mapped **bmRequestType** field identifies the characteristics of the USB command per Chapter 9 of the USB Specification. Fields included in this command describe the direction of the transfer, type of request (core, class, or vendor specific) and the target of the command recipient (device, interface, or endpoint). The only variation on the **bmRequestType** field for the different DS2490 vendor-specific command will be for the transfer direction: host to device, or device to host; the recipient for all commands will be the “device”.

The **bRequest** field contains a 1-byte constant identifying which of the three supported DS2490 command types is being sent. The command constants are defined in Appendix 4 and are summarized as follows:

<u>Command Type</u>	<u>Description</u>
CONTROL_CMD	1-Wire interface control commands
COMM_CMD	1-Wire interface communication commands
MODE_CMD	1-Wire interface operational mode commands

The 2-byte **wValue** field is encoded with the specific command. For Control and Mode commands, the field value corresponds to a specific command constant as defined in Appendix 4. For Communication

commands, the field has additional embedded command parameters as indicated in Appendix 2. The exception is the READ STRAIGHT command as described previously.

The 2-byte **wIndex** is used to hold additional command parameter data when required by the specific command.

The **wLength** field is used in the control transfer setup packet to specify the number of bytes to be sent during the data stage of a control transfer. The “GET COMM CMDS” control command is the only DS2490 command that uses the data stage of the control transfer. Typically all command data is embedded in the setup stage. Except for the GET COMM CMDS, this field must be set to 0x0000.

DS2490 Control, Communication, and Mode vendor-specific command descriptions and formatting are defined in Appendices 1, 2, and 3. Vendor-specific commands not defined in the appendices are not supported by the DS2490 and the device will respond with a STALL if an unsupported command is received.

MODE COMMANDS

DS2490 1-Wire characteristics and features (speed, durations, slew rate, etc.) are controlled with discrete Mode commands and/or embedded Communication command parameters. Parameter values and enable/disable settings are used for characteristic control. Mode settings are stored in the DS2490 State Registers and can be read at any time or at the polling interval of EP1. See the section “DEVICE FEEDBACK” for State Register details.

Enable/disable settings are used to control three global features:

- Strong pullup to +5V
- +12V EPROM programming pulse
- Dynamic 1-Wire bus communication speed change through a communication command

The setting for these three global controls are accessible only through Mode commands; the features are either enabled or disabled with the appropriate Mode command. Specific Communication commands exist which can be used to issue a strong pullup, programming pulse, or speed change. When the corresponding setting is enabled the feature is usable as part of a communication command when disabled the feature is not usable.

Parameter values and codes are used to specify and control 1-Wire bus characteristics:

- 1-Wire bus communication speed
- +5V strong pullup duration
- +12V programming pulse duration
- Pulldown slew rate
- Write-1 low time
- Data sample offset/ Write-0 Recovery time

These six settings are controllable with discrete Mode commands or as embedded command/parameter values in Communications commands.

As listed in Table 5 and summarized previously, there are eight Mode commands. The USB control transfer setup packet coding to transmit these commands is detailed in Appendix 3. Mode commands are immediately processed by the DS2490 when they are received. The DS2490 power-on default values for

these parameters are as listed in Table 10. Each command and parameter control is detailed in the following paragraphs.

Mode Command Set Summary Table 5

Command	Function
ENABLE PULSE	Enable/disable 1-Wire strong pullup pulse to 5V and/or +12V programming pulse.
ENABLE SPEED CHANGE	Enable/disable dynamic change of the 1-Wire speed through a communication command.
1-WIRE SPEED	Communication speed of the 1-Wire bus.
STRONG PULLUP DURATION	Duration of 1-Wire strong pullup.
PULLDOWN SLEW RATE	Slew rate of 1-Wire pulldown.
PROG PULSE DURATION	Duration of 1-Wire VPP EPROM programming pulse.
WRITE-1 LOW TIME	Duration of 1-Wire Write-1 low time.
DSOW0 RECOVERY TIME	Recovery time for the 1-Wire data sample offset / Write-0 transaction.

Mode Command Set Descriptions:

ENABLE PULSE – This command is used to enable or disable a 1-Wire strong pullup pulse to 5V and/or +12V EPROM programming pulse. Two bit positions in the parameter byte are used to control the enabled/disabled state for each pulse type. The specific pulse is enabled when the respective bit is set to a 1 and disabled when set to a 0. The DS2490 power-up default state for both strong pullup and programming pulse is disabled.

ENABLE SPEED CHANGE - This command is used to enable or disable a 1-Wire communication speed change. Enabled when a TRUE parameter value is passed with the command, disabled with a FALSE. The DS2490 power-up default state for speed change is disabled.

1-WIRE SPEED - This command is used to set the speed of 1-Wire communication; three settings are possible. The parameter codes to select the desired or required speed are as listed in Table 6. As shown, speed codes 0x3..0xF are undefined. The DS2490 decodes the 3 LSBs of the 1-Wire speed code. Sending a code other than the defined values in Table 6 will result in undefined behavior. The DS2490 power-up default communication speed is regular.

1-Wire Bus Speed Codes Table 6

Code	Speed	Data Rate
0x0	Regular	65 μ s time slot (15.4 kbps)
0x1	Flexible	65- 72 μ s time slot (13.9 to 15.4 kbps)
0x2	Overdrive	10 μ s time slot (100 kbps)
0x3..0xF	reserved	undefined

STRONG PULLUP DURATION - This command is used to set the time duration of a 1-Wire strong Pullup. The time is controlled with an unsigned 8-bit binary number between 0x00 and 0xFE which specifies the duration in multiples of 16 ms. A value of 0x01 specifies 16 ms, 0x02 equals 32 ms, etc. A value of 0x00 specifies infinite duration. To terminate an infinite duration pullup use either the HALT EXECUTION WHEN DONE or HALT EXECUTION WHEN IDLE Control commands as described in Appendix 1. A value of 0xFF specifies semi-indefinite duration. For a semi-indefinite duration, the strong pullup will end as soon as the current has dropped below $500 \mu\text{A} \pm 50\%$. The current is sensed every 16 ms. The DS2490 power-up default strong pullup duration register value is 512 ms.

PROG PULSE DURATION - This command is used to set the time duration of a 1-Wire Programming Pulse. The time is controlled with a an unsigned 8-bit binary number between 0x00 and 0xFE specifying the duration in multiples of 8 μs . A value of 0x00 stands for infinite duration. To terminate an infinite duration programming pulse use the HALT EXECUTION WHEN DONE or HALT EXECUTION WHEN IDLE command. A value of 0xFF stands for semi-indefinite duration. The pulse will end as soon as the current has dropped below $500 \mu\text{A} \pm 50\%$. The current is sensed every 8 μs . The pulse will also terminate if the voltage sensed on the 1-Wire bus remains too low. The DS2490 power-up default strong pullup duration register value is 512 μs .

PULLDOWN SLEW RATE - This command is used to select the pulldown slew rate for 1-Wire bus Flexible Speed operation; eight pulldown slew rates are possible. The parameter codes to select the desired or required slew rate are as listed in Table 7. The slew rate numbers in the table represent typical values. The pulldown slew rate for Regular speed is $0.83 \text{ V}/\mu\text{s}$ and for Overdrive speeds it is $15 \text{ V}/\mu\text{s}$. The DS2490 decodes the 3 LSBs of the slew rate code. Sending a code other than the defined values in Table 7 will result in undefined behavior. The DS2490 pulldown slew rate power-up default value for Flexible speed is $0.83 \text{ V}/\mu\text{s}$.

Flexible Speed PullDown Slew Rate Codes Table 7

Code	Pulldown slew rate
0x0	15 V/ μs
0x1	2.20 V/ μs
0x2	1.65 V/ μs
0x3	1.37 V/ μs
0x4	1.10 V/ μs
0x5	0.83 V/ μs
0x6	0.70 V/ μs
0x7	0.55 V/ μs
0x8..0xF	reserved

WRITE-1 LOW TIME - This command is used to select the Write-1 low time for 1-Wire bus Flexible speed operation; eight Write-1 low time durations are possible. The parameter codes to select the desired or required low time are as listed in Table 8. The low time numbers in the table represent exact values. The Write-1 Low Time for Regular speed is 8 μs , at Overdrive speed it is 1 μs . The DS2490 decodes the 3 LSBs of the low time code. Sending a code other than the defined values in Table 8 will result in undefined behavior. The DS2490 Write-1 Low Time power-up default value for Flexible speed is 12 μs .

Flexible Speed Write-1 Low Time Codes Table 8

Code	Write-1 Low Time
0x0	8 μ s
0x1	9 μ s
0x2	10 μ s
0x3	11 μ s
0x4	12 μ s
0x5	13 μ s
0x6	14 μ s
0x7	15 μ s
0x8..0xF	reserved

DSOW0 RECOVERY TIME - This command is used to select the Data Sample Offset / Write-0 recovery time (DSO/W0R) for 1-Wire bus Flexible Speed operation; eight DSO/W0R times are possible. The parameter codes to select the desired or required recovery time are as listed in Table 9. The numbers in the table represent exact values. The DSO/W0R time for Regular speed is 3 μ s, for Overdrive speed the Data Sample Offset is 1 μ s and the Write-0 Recovery Time is 3 μ s. The DS2490 decodes the 3 LSBs of the DSO/W0R code. Sending a code other than the defined values in Table 9 will result in undefined behavior. The DS2490 DSO/W0R power-up default value for Flexible speed is 7 μ s.

Flexible Speed DSO/ W0R Time Codes Table 9

Code	DSO/W0R Time
0x0	3 μ s
0x1	4 μ s
0x2	5 μ s
0x3	6 μ s
0x4	7 μ s
0x5	8 μ s
0x6	9 μ s
0x7	10 μ s
0x8..0xF	reserved

Power-on Default Mode Values

Table 10 summarizes the power-up default values for the various DS2490 mode registers. Note that the power-up default communication speed is regular and several of the values listed in Table 10 are specific to Flexible speed operation. To change a value the appropriate Mode or Communication command must be sent to the device.

1-Wire Power-On Default Modes Table 10

Setting/Parameter	Power-On Default Value
Strong pullup to 5V	FALSE
12V Programming Pulse	FALSE
Dynamic Speed Change	FALSE
1-Wire Bus Communication Speed	0x0 (Regular Speed, ~16 kbps)
+5V Strong Pullup Duration	0x20 (512 ms)
+12V Programming Pulse Duration	0x40 (512 μ s)
Pulldown Slew Rate Control	0x5 (0.83 V/ μ s)
Write-1 Low Time	0x4 (12 μ s)
Data Sample Offset / Write-0 Recovery Time	0x4 (7 μ s)

CONTROL COMMANDS

DS2490 Control commands are used to control the processing of Communication commands/data and can also be used to issue a device Reset. As listed in Table 11 there are 11 Control commands. The USB control transfer setup packet coding to transmit these commands is detailed in Appendix 1. Like Mode commands, Control commands are immediately processed by the DS2490 when they are received.

Control Command Set Summary Table 11

Command	Function
RESET DEVICE	Perform a hardware reset.
START EXECUTION	Start execution of Communication commands.
RESUME EXECUTION	Resume execution of Communication commands.
HALT EXECUTION WHEN IDLE	Halt Communication command execution when the 1-Wire bus is idle.
HALT EXECUTION WHEN DONE	Halt further Communication command execution when the current command execution completes.
CANCEL COMMAND	Terminate Communication command execution.
CANCEL MACRO	Terminate Communication command macro execution.
FLUSH COMM CMDS	Clear unexecuted Communication commands from the command buffer.
FLUSH DATA RCV BUFFER	Clear the data receive buffer (data from a 1-Wire device).
FLUSH DATA XMT BUFFER	Clear the data transmit buffer (data to a 1-Wire device).
GET COMM CMDS	Retrieve unexecuted Communication commands from the command buffer.

Control Command Set Descriptions:

RESET DEVICE – This command performs a hardware reset equivalent to the power-on reset. This includes clearing all endpoint buffers and loading the Mode control registers with their default values.

START EXECUTION – This command starts execution of Communication commands. This command is also required to start the execution of Communication commands with an IM (immediate execution control) bit set to logic 0.

RESUME EXECUTION – This command is used to resume execution of a Communication command that was halted with either of the HALT EXECUTION commands.

HALT EXECUTION WHEN IDLE – This command is used to halt the execution of the current Communication command after the 1-Wire bus has returned to the idle state. Further Communication command processing is stopped until a RESUME EXECUTION command is received. This command, or the HALT EXECUTION WHEN DONE command, is also used to terminate a strong pullup or programming pulse of semi-infinite or infinite duration.

HALT EXECUTION WHEN DONE – This command is used to halt the execution of a Communication command after the current command execution is complete. Further Communication command processing is stopped until a RESUME EXECUTION command is received. This command, or the HALT EXECUTION WHEN IDLE command, is also used to terminate a strong pullup or programming pulse of semi-infinite or infinite duration.

CANCEL COMMAND – This command is used to terminate the Communication command that is currently being executed and place the 1-Wire bus in an idle state. Further Communication command processing is stopped until a START EXECUTION command is received. The canceled Communication command cannot be resumed. The DS2490 must be in a halted state before the CANCEL COMMAND command can be processed, if not, the command will be ignored.

CANCEL MACRO - This command is used to terminate any activity on the 1-Wire bus without completing the Communication command or macro that is currently being executed and to place the 1-Wire bus in an idle state. The command processing pointer is positioned at the communication command that follows the set of commands that make up the macro. Further Communication command processing is stopped until a START EXECUTION command is received. The DS2490 must be in a halted state before the CANCEL MACRO command can be processed; if not, the command will be ignored.

FLUSH COMM CMDS - This command is used to clear all unexecuted Communication commands from the command FIFO. The DS2490 must be in a halted state before the FLUSH COMM CMDS command can be processed.

FLUSH DATA RCV BUFFER - This command is used to clear EP3 receive data FIFO (data from 1-Wire device). The DS2490 must be in a halted state before the FLUSH DATA RCV BUFFER command can be processed.

FLUSH DATA XMT BUFFER - This command is used to clear EP2 transmit data FIFO (data to 1-Wire device). The DS2490 must be in a halted state before the FLUSH DATA XMT BUFFER command can be processed.

GET COMM CMDS - This command is used to retrieve unexecuted Communication commands and parameters from the command FIFO. The DS2490 must be in a halted state before the GET COMM CMDS command can be processed. Unexecuted commands are returned over EP0 in the control transfer data phase. Host software is responsible for determining the number of command/parameter bytes to be returned and specifying the value in the wLength field of the control transfer setup packet. Commands/parameters are deleted from the FIFO as they are transmitted to the host; the command pointer used with the FIFO is updated as values are read. Any commands/parameters that are not transferred remain in the FIFO and will be processed when command execution resumes. If the wLength value passed is larger than the number of command/parameter bytes, the DS2490 will terminate the control transfer with a short data packet.

COMMUNICATION COMMANDS

Communication commands are used to communicate with and control an attached 1-Wire device(s). There are 16 commands as summarized in Table 12. Communication commands also contain embedded command bits for conditional control or additional functionality. Appendix 2 details the embedded command bit purpose/formatting as well as the control transfer setup packet coding to transmit the command/parameter data to the DS2490.

Unlike Mode and Control commands, Communication command processing is controlled by host software by combining embedded command bits with Control commands. For example, a command macro form is supported in which several Communication commands and parameter data are sent/buffered in the DS2490 and then processed as a group. Embedded command bit ICP is used to create macro command sets. Also unlike Mode and Control commands, several forms of Communication command monitoring exists for host software to track processing progress. If an error condition is detected during command processing and the embedded ICP bit is set to the proper state or the ERROR ESCAPE command is used, a Result Register value will be generated with an error indication. Note that a Result Register value will not be generated if no error condition is detected. Communication command buffer (FIFO) status and 1-Wire data transmit/received buffers (EP2/3 FIFOs) status can also be

monitored via the State Registers. See the section “DEVICE FEEDBACK” for details on command monitoring.

Communication Command Set Summary Table 12

Command	Function
ERROR ESCAPE	Escape from macro on error.
SET DURATION	Change duration of strong pullup or programming pulse.
PULSE	Perform strong pullup or generate programming pulse.
1-WIRE RESET	Generate 1-Wire reset pulse.
BIT I/O	1-Wire single data bit I/O.
BYTE I/O	1-Wire data byte I/O.
BLOCK I/O	1-Wire data block I/O.
MATCH ACCESS	Address a device on the 1-Wire bus.
READ STRAIGHT	Transmit a data preamble and read back data.
DO & RELEASE	Control Crypto <i>i</i> Button CPU activity.
SET PATH	Activate a series of couplers that provide access to a target 1-Wire device.
WRITE SRAM PAGE	Write data to the scratchpad of a 1-Wire SRAM device.
WRITE EPROM	Write data directly to the data or status memory of a 1-Wire EPROM device.
READ CRC PROT PAGE	Read CRC protected pages of a 1-Wire EPROM device or tamper-detect bytes and counter value of Monetary <i>i</i> Buttons.
READ REDIRECT PAGE W/CRC	Read a single page of data and check the CRC. Follow page redirections if set.
SEARCH ACCESS	Access a device using the Search ROM command or identifying devices on the active segments of a MicroLAN.

Communication Command Set Descriptions:

ERROR ESCAPE - This command can be placed between commands in a macro. If an error condition occurred when executing the Communication command prior to the ERROR ESCAPE command, further Communication command processing will be stopped and a Result Register processing error indication byte will be loaded in the feedback data buffer to be sent to the host. (See the section “DEVICE FEEDBACK” and Table 17 for a Result Register description.) If an error condition was detected, host intervention is required to recover from the ERROR ESCAPE state. If no error occurred, the command is processed as a NO OPERATION. Embedded command bit RST enables a 1-Wire reset before the command executes.

Note: The ERROR ESCAPE command **should not** be used as the last command of a macro. Nor should the ERROR ESCAPE command be used between individual communication commands; it should only be used within a macro command set. If this requirement is violated and the ERROR ESCAPE command is used as the last macro command or between individual instructions, the potential exists for the macro or individual instruction following the ERROR ESCAPE to be skipped and purged from command FIFOs. Additionally, it is not necessary since, by requirement, the last macro command must have its embedded ICP bit set to (ICP=1, see APPENDIX 2 for command coding); this will force error reporting.

Command parameters:	None.	
EP2 data:	None.	
EP3 data:	None.	
Result Register:	Code	Condition
	EOS, RDP, CRC, CMP, VPP, APP, SH, NRS	Error during execution of the previous command.
	None.	No error occurred during execution of the previous command.

SET DURATION - This command changes the State Register pulse duration value for either the +12V programming pulse or strong pullup. The new duration value is loaded into the duration register specified by the TYPE embedded command parameter as detailed in Appendix 2. See section “MODE COMMANDS” for duration parameter value setting. The duration values can alternatively be changed using a Mode command.

Note: An infinite duration pulse is terminated by using either of the HALT EXECUTION Control commands. To resume 1-Wire activity after the termination, use the RESUME EXECUTION Control command.

Command parameters:	1 byte specifying the new duration.
EP2 data:	None, this command gets its input data as a command parameter.
EP3 data:	None.
Result Register:	None, this command returns no error code.

PULSE - This command is used to temporarily pull the 1-Wire bus to +12V in order to program an EPROM device or to generate a strong pullup to 5V in order to provide extra power for an attached iButton device, e.g., temperature sensor or crypto iButton. The embedded TYPE parameter bit specifies the pulse type. The pulse duration is determined by the value in the respective mode register, programming pulse or strong pullup. The 12VP bit in the Device Status Flags (bit2) is used to determine whether +12V VPP programming voltage is present, see Table 15.

Command parameters:	None.	
EP2 data:	None.	
EP3 data:	None.	
Result Register:	Code	Condition
	VPP.	ICP=0 and no +12V was sensed.
	Non.	Otherwise.

1-WIRE RESET - This command is used to generate a reset pulse on the 1-Wire bus and to optionally change the 1-Wire speed. The new speed will take effect only if the embedded command bit SE is set to 1. When the 1-WIRE RESET is sent after an Overdrive Skip ROM command, SE must be 1 and the new speed must be 0x02. See MODE CONTROL section for additional communication speed information. To switch back to regular speed, set SE=1 and the new speed parameter to 0x00 (regular) or 0x01 (flexible).

Command parameters:	1 byte specifying new speed after the reset.
EP2 data:	None.

EP3 data:	None.	
Result Register:	Code	Condition
	SH, NRS.	ICP=0 and an abnormal condition.
	None.	Otherwise.

BIT I/O - This command generates a single time slot on the 1-Wire bus and reads back the response. Data bit d3 (D) of command byte 1 specifies the value to be written to the 1-Wire bus. This time slot may optionally be followed by a strong pullup using embedded command bits SPU and CIB. With CIB=1, a requested strong pullup will only occur if the read-back revealed a 0. Data is returned to the host only if the embedded command bit ICP=0. If ICP=0, the bit read from the 1-Wire device is stored in the EP3 FIFO and is read by the host using an EP3 bulk transaction. The bit read back is stored in the data byte LSB as shown in Table 13.

Command parameters:	None.	
EP2 data:	None, this command gets its input data as a command parameter.	
EP3 data:	Length	Description
If ICP=0:	1 byte	Bit read back from the 1-Wire device.
If ICP=1:	None.	No data is returned.
Result Register:	None, this command returns no error code.	

BIT I/O Read Back Byte Table 13

bit7	bit6	bit5	bit4	bit3	bit2	bit1	bit0
0	0	0	0	0	0	0	D

BYTE I/O - This command accomplishes a direct 1-Wire write and read with optional strong pullup after the last bit of the byte. The optional strong pullup is controlled using embedded command bit SPU. For a write sequence, the data byte to be written is included in the command setup packet as shown in Appendix 2. For a read sequence the setup packet data byte value is set to 0xFF. Data is returned to the host only if the embedded command bit ICP=0. If ICP=0, the byte read from the 1-Wire device is stored in the EP3 FIFO and is read by the host using an EP3 bulk transaction.

Command parameters:	1 byte: Data byte to be sent to the 1-Wire bus. To read only, the byte should be 0xFF.	
EP2 data:	None, this command gets its input data as a command parameter.	
EP3 data:	Length	Description
If ICP=0:	1 byte	Byte read back from the 1-Wire device.
If ICP=1:	None	No data is returned.
Result Register:	None, this command returns no error code.	

BLOCK I/O - This command accomplishes a direct 1-Wire write or read with optional strong pullup after the last byte of the block. The optional strong pullup is controlled using embedded command bit SPU. Embedded command bit RST enables a 1-Wire reset before the command executes. To accomplish a READ function all input data should be 0xFF, otherwise the data read from the 1-Wire bus will be masked. For a block write sequence the EP2 FIFO must be pre-filled with data before command execution. Additionally, for block sizes greater than the FIFO size, the FIFO content status must be monitored by host SW so that additional data can be sent to the FIFO when necessary. A similar EP3 FIFO content monitoring requirement exists for block read sequences. During a block read the number of

bytes loaded into the EP3 FIFO must be monitored so that the data can be read before the FIFO overflows. See the HW/SW APPLICATION RECOMMENDATION section for additional details.

Command parameters:	2 bytes specifying block size.	
EP2 data:	Length	Description
	Same as block size	Data block to be written to the 1-Wire device.
EP3 data:	Length	Description
	Same as block size	Data block read from the 1-Wire device.
Result Register:	None, this command returns no error code.	

MATCH ACCESS - This command is used to address a device on the active section of the 1-Wire bus using the Match ROM or Overdrive Match command code. The EP2 FIFO must be pre-filled with the 8 bytes target ROM ID before command execution. Embedded command bit RST enables a 1-Wire reset before the command executes, and embedded command bit SE enables a 1-Wire speed change that takes effect before the command executes.

Command parameters:	2 bytes: match command byte, new 1-Wire speed byte (optional).	
EP2 data:	Length	Description
	8 bytes	ROM ID of the device to be accessed.
EP3 data:	None	
Result Register:	None, this command returns no error code.	

READ STRAIGHT - This command transmits a user-specified preamble of data to the 1-Wire bus and then reads back as many bytes as specified. The preamble typically consists of a 1-Wire command code followed by TA1 and TA2. It is possible to include a Match ROM command and ROM ID in the preamble to also address a device at the current speed. This command can also be used to copy the scratchpad or disconnect a path. Embedded command bit RST enables a 1-Wire reset before the command executes. The EP2 FIFO must be pre-filled with preamble data before command execution. Additionally, for preamble sizes greater than the FIFO size, the FIFO content status must be monitored by host SW so that additional data can be sent to the FIFO when necessary. A similar EP3 FIFO content monitoring requirement exists for the block read. During a block read the number of bytes loaded into the EP3 FIFO must be monitored so that the data can be read before the FIFO overflows. See the HW/SW APPLICATION RECOMMENDATION section for additional details.

Command parameters:	3 bytes: 2-byte parameter specifying block read size, byte specifying preamble size.	
EP2 data:	Length	Description
	Same as preamble size	Preamble data to be written to the 1-Wire device.
EP3 data:	Length	Description
	Same as block size	Data block read from the 1-Wire device.
Result Register:	None, this command returns no error code.	

DO & RELEASE - This command is typically used to control the activity of the CPU of the crypto iButton, which requires a release sequence. This command can also be used to read from or write to the I/O buffer or Status Register of the crypto iButton. A short preamble (3 bytes) consists of a 1-Wire

command code followed by the release sequence. A four-byte preamble with embedded command bit R = 1 consists of a 1-Wire command code followed by length byte and the release sequence. A 4-byte preamble with embedded command bit R = 0 consists of a 1-Wire command code followed by a status byte and the release sequence. The long preamble (minimum 5 bytes, embedded command bit R = 0) consists of a 1-Wire command, a length byte, data bytes and the release sequence. In this case the length byte indicates the total number of bytes between the length byte and release sequence. The least significant byte of the release sequence is transmitted first. Embedded command bit SPU must be 1 when trying to run (start, continue) the CPU of the crypto *i*Button. In all other cases, SPU should be 0. Additionally, embedded command bit F can be used to clear the communication command buffer and EP2, 3 FIFOs if an error occurs during execution of the command. The EP2 FIFO must be pre-filled with preamble data before command execution. Additionally, for preamble sizes greater than the FIFO size, the FIFO content status must be monitored by host SW so that additional data can be sent to the FIFO when necessary.

A similar EP3 FIFO content monitoring requirement exists for the block read. During a block read the number of bytes loaded into the EP3 FIFO must be monitored so that the data can be read before the FIFO overflows. See the HW/SW APPLICATION RECOMMENDATION section for additional details.

Command parameters:	1 byte specifying preamble size.	
EP2 data:	Length	Description
	Same as preamble size	Preamble data to be written to the 1-Wire device.
EP3 data:	Length	Description
If R=1 and preamble size ≥ 4 :	As specified in the second byte of the preamble	Data read from the 1-Wire device.
If R=0:	None	No data is returned (this is a write application).
Result Register:	Code	Condition
	CRC, CMP	ICP=0: bad CRC or the release sequence was not accepted.

SET PATH - This command is used to activate a series of couplers that finally provide the access to the target 1-Wire device. Embedded command bit RST enables a 1-Wire reset before the command executes. Additionally, embedded command bit F can be used to clear the communication command buffer and EP2,3 FIFOs if an error occurs during execution of the command. The EP2 FIFO must be pre-filled with coupler data before command execution. Additionally, for coupler data sizes greater than the EP2 FIFO size, the FIFO content status must be monitored by host SW so that additional data can be sent to the FIFO when necessary. Upon completion of command execution, the EP3 FIFO is loaded with a 1-byte value that indicates the number of couplers activated. See the HW/SW APPLICATION RECOMMENDATION section for additional details. An NRS error code is an indication that there was no presence pulse on the branch that was to be connected.

Command parameters:	1 byte specifying number of couplers that need to be activated to set-up the path to the target device.	
EP2 data:	Length	Description
	9 bytes per level	8 bytes ROM ID of the coupler to be activated followed by the Smart-On command code for either the main or auxiliary 1-Wire coupler output.
EP3 data:	Length	Description
	1 byte	Number of couplers successfully activated; should be the same as the number of levels.
Result Register:	Code	Condition
	CMP, SH, NRS	ICP=0 and an error condition.
	None	Otherwise.

WRITE SRAM PAGE - This command is used to write data to the scratchpad of an SRAM device and optionally check the CRC. To copy the data to its final memory location, it is required to send the READ STRAIGHT command with a “copy scratchpad” preamble and a 0 block size. Embedded command bit DT=1 activates the CRC16 generator. This command is also applicable to the Write IPR function of the Crypto iButton if embedded command bit CIB=1. To write a partial page the page size parameter and the target address need to be set accordingly. The EP2 FIFO must be pre-filled with preamble and SRAM data before command execution. Additionally, for data page sizes greater than the EP2 FIFO size, the FIFO content status must be monitored by host SW so that additional data can be sent to the FIFO when necessary. See the HW/SW APPLICATION RECOMMENDATION section for additional details.

Command parameters:	1 byte specifying page size. This specifies the number of bytes to be sent to the 1-Wire device following a 2- or 3-byte preamble. This number is typically identical to the page size; a value of 0x00 indicates a 256-byte page.	
EP2 data:	Length	Description
If CIB=0:	3-bytes + page size	Preamble and data bytes to be sent to the 1-Wire SRAM device. 3-byte preamble: 1-Wire command code, TA1, TA2 (typical).
If CIB=1:	2-bytes + page size	Preamble and data bytes to be sent to the 1-Wire SRAM device. 2-byte preamble: 1-Wire command code, length information.
EP3 data:	None	
Result Register:	Code	Condition
	CRC	ICP=0 and an error condition (only if DT=1).
	None	Otherwise.

WRITE EPROM - This command is used to write data directly to the data or status memory of a 1-Wire EPROM device. If embedded command bit DT=1, the CRC16 generator is selected; if DT=0, CRC8 is used. Embedded command bit Z controls the method used for comparison of the data written to the 1-Wire device. Additionally, embedded command bit F can be used to clear the Communication command buffer and EP2, 3 FIFOs if an error occurs during execution of the command. The EP2 FIFO must be pre-filled with preamble and EPROM data before command execution. Additionally, for data block sizes greater than the EP2 FIFO size, the FIFO content status must be monitored by host SW so that additional

data can be sent to the FIFO when necessary. See the HW/SW APPLICATION RECOMMENDATION section for additional details.

Command parameters:	2 bytes specifying block size.	
EP2 data:	Length	
	3-bytes + block size	Preamble and data bytes to be sent to the 1-Wire EPROM device. 3-byte preamble: 1-Wire command code, TA1, TA2 (typical).
EP3 data:	None	
Result Register:	Code	Condition
	CRC, CMP, VPP	ICP=0 and an error condition.

READ CRC PROT PAGE - This command is used to read one or multiple CRC-protected pages of EPROM devices and to read tamper-detect bytes and counter value of Monetary *i*Buttons. If embedded command bit DT=1, the CRC16 generator is selected; if DT=0, CRC8 is used. Embedded command bit CIB is used to specify either a 2- or 3-byte read preamble. Additionally, embedded command bit F can be used to clear the Communication command buffer and EP2, 3 FIFOs if an error occurs during execution of the command. The command can also be used to read a single partial page up to the end of that page and reading the PIOs of a DS2407. This command is also applicable to the Read IPR function of the crypto *i*Button if CIB=1. The EP2 FIFO must be pre-filled with preamble data before command execution. To prevent overflow, the EP3 FIFO must be monitored (and read if necessary) during command execution if reading more data than the size of the EP3 FIFO. See the HW/SW APPLICATION RECOMMENDATION section for additional details.

Command parameters:	2 bytes: 1 byte page size, 1 byte number of pages. Page size byte indicates the number of bytes that are considered a page; typical is 32 decimal for data memory, 8 for status memory, and 40 decimal for Monetary <i>i</i> Buttons. A page size of 0x00 indicates a 256-byte page.	
EP2 data:	Length	
If CIB=0:	3-bytes	3-byte preamble: 1-Wire command code, TA1, TA2 (typical).
If CIB=1:	2-bytes	2-byte preamble: 1-Wire command code, length information.
EP3 data:	Length	Description
	(page size x number of pages)	Data read from the 1-Wire device..
Result Register:	Code	Condition
	CRC	ICP=0 and an error condition.

READ REDIRECT PAGE W/CRC - This command is used to read a single page of data and check the CRC. If the page is not redirected, the host will receive the page number and all its data. If the page is redirected and embedded command bit CH=1 the device will follow the trail of redirections until a page is found that is not redirected. When found, the host will receive the page number and all data of that particular page. If CH = 0 and the first read attempt reveals a redirection the host will only receive the number of the page the addressed page is redirected to. Reading starts at a page boundary. Additionally, embedded command bit F can be used to clear the communication command buffer and EP2, 3 FIFOs if an error occurs during execution of the command. An NRS error code is an indication of an infinite loop.

The EP2 FIFO must be pre-filled with ROM ID and command code data before command execution. To prevent overflow, the EP3 FIFO must be monitored (and read if necessary) during command execution if reading more data than the size of the EP3 FIFO. See the HW/SW APPLICATION RECOMMENDATION section for additional details.

Command parameters:	2 bytes: 1 byte page size, 1 byte page address. Page size byte indicates the number of bytes that are considered a page; typical is 32 decimal for data memory, 8 for status memory, and 40 decimal for Monetary iButtons. A page size of 0x00 indicates a 256-byte page. The page address specifies the page number to be used for the first read attempt.	
EP2 data:	Length	
	9 bytes	8 bytes ROM ID of the 1-Wire device to be accessed followed by the 1-Wire command code for “Extended Read Memory”.
EP3 data:	Length	Description
If CH=1 or page is not redirected:	1 byte + page size	Page number and contents of the page.
If CH=0 and page is redirected:	1 byte	Number of the page the addressed page is redirected to.
Result Register:	Code	Condition
	RDP, CRC, NRS	ICP=0 and an error condition.

SEARCH ACCESS - The SEARCH ACCESS command is used to either access a device using the Search ROM command or to identify the devices on the active segments of a MicroLAN. Embedded command bit SM is used to specify the type of search. Embedded command bit RTS is used to control discrepancy information reporting. Additionally, embedded command bit F can be used to clear the Communication command buffer and EP2, 3 FIFOs if an error occurs during execution of the command. An NRS error code indicates that there was no response on at least one of the 64 bits of the ROM search. The EP2 FIFO must be pre-filled with ROM ID data before command execution. To prevent overflow, the EP3 FIFO must be monitored (and read if necessary) during command execution if returning more data than the size of the EP3 FIFO. See the HW/SW APPLICATION RECOMMENDATION section for additional details.

Command parameters:	2 bytes: 1 byte 1-Wire command, 1 byte number of devices. The 1-Wire command is a valid command for addressing a 1-Wire device. The number of devices byte specifies the maximum number of devices to be discovered in a single command call. A value of 0x00 indicates that all devices on the MicroLAN are to be discovered.	
EP2 data:	Length	
	8 bytes	ROM ID of the 1-Wire device to be accessed (SM=0) or ROM ID with which to start the search (SM=1).
EP3 data:	Length	Description
If SM=0:	None	No data is returned.
If SM=1:	Varies, blocks of 8 bytes.	ROM IDs of the devices discovered followed by 8 bytes discrepancy information (if RTS=1 and the numbers of devices on the MicroLAN is higher than specified in the second parameter).
Result Register:	Code	Condition
	EOS, NRS	ICP=0 and an error condition.

DEVICE FEEDBACK

DS2490 state and result feedback are provided to the host over the EP1 interrupt pipe. The host interrupt polling period for EP1 transfers is controlled by the alternate setting of the 1-Wire USB Interface as described in the section: 1-Wire Interface Summary Description. As shown in Table 14, up to 32 bytes of feedback data are returned. As a minimum, 16 bytes of STATE REGISTER data will be delivered at each polling interval (or USB IN transaction to EP1); the position and definition of these data values are listed in Table 15. In addition, as shown in Table 16, between 0 and 16 extra bytes of RESULT REGISTER data will be delivered which could contain communication command error data or a 1-Wire device detect byte. If there are less than 32 bytes of result and state register data to return, the DS2490 will terminate the IN transaction with a short or zero data packet.

Data is loaded into the RESULT REGISTER buffer if a communication command error occurs or upon detection of a 1-Wire device attachment. There is no defined offset position for data values in this buffer. Knowledge of communication command ordering sent to the DS2490 must be maintained on the host to properly interpret the returned data values. In addition, a parse of the data is required to determine whether or not a 1-Wire detect value is included; the value of the 1-Wire detect byte is unique. Table 17 defines the 1-Wire detect byte and data values that result from Communication command processing.

Interrupt Transfer Data Summary Table 14

OFFSET	DATA
0x00 - 0x0F	STATE REGISTERS
0x10 – 0x1F*	RESULT REGISTERS

*The number of RESULT REGISTER values will vary depending on error conditions encountered while processing Communication commands or whether a 1-Wire device was detected.

DS2490 STATE REGISTERS Table 15

Description	Offset	Data							
		bit7	bit6	bit5	bit4	bit3	bit2	bit1	bit0
Enable Flags	0x00	--	--	--	--	--	SPCE	PRGE	SPUE
		SPUE If set to 1 the strong pullup to 5V is enabled, if set to 0 it is disabled.							
		PRGE If set to 1 a 12V programming pulse is enabled, if set to 0 it is disabled.							
		SPCE If set to 1 a dynamic 1-Wire bus speed change through a Communication command is enabled, if set to 0 it is disabled.							
		bit 3..7 These bits are reserved.							
1-Wire Speed	0x01	current 1-Wire bus speed code							
Strong Pullup Duration	0x02	current pullup duration							
Programming Pulse Duration	0x03	current programming pulse duration							
Pulldown Slew Rate Control	0x04	current pulldown slew rate code							
Write-1 Low Time	0x05	current Write-1 low time code							
Data Sample Offset / Write-0 Recovery Time	0x06	current data sample offset/ Write-0 recovery time code							
Reserved (Test Register)	0x07								
Device Status Flags	0x08	bit7	bit6	bit5	bit4	bit3	bit2	bit1	bit0
		--	--	IDLE	HALT	PMOD	12VP	PRGA	SPUA
		Bit Definitions:							
		SPUA if set to 1 the strong pullup to 5V is currently active, if set to 0 it is inactive.							
		PRGA if set to 1 a 12V programming pulse is currently being generated, if set to 0 it is not.							
		12VP if set to 1 the external 12V programming voltage is present, if set to 0 it is not present.							
		PMOD if set to 1 the DS2490 is powered from USB and external sources, if set to 0 all DS2490 power is provided from USB.							
		HALT if set to 1 the DS2490 is currently halted, if set to 0 the device is not halted.							
		IDLE if set to 1 the DS2490 is currently idle, if set to 0 the device is not idle.							
bit 6..7: reserved									
Communication Command, Byte 1	0x09	Communication command currently being processed. If the device is idle a register value of 0x00 is sent.							
Communication Command, Byte 2	0x0A	Communication command currently being processed. If the device is idle a register value of 0x00 is sent.							

Description	Offset	Data
Communication Command Buffer Status	0x0B	Number of data bytes currently contained in the 16-byte FIFO used to hold communication commands.
1-Wire Data Out Buffer Status	0x0C	Number of data bytes currently contained in the 128-byte FIFO used to write data to the 1-Wire bus.
1-Wire Data In Buffer Status	0x0D	Number of data bytes currently contained in the 128-byte command FIFO used to read data from the 1-Wire bus.
Reserved (Test Register)	0x0E	reserved
Reserved (Test Register)	0x0F	reserved

DS2490 RESULT REGISTERS Table 16

Offset ^{1,2}	Data
0x10	value
0x11	value
...	...
0x1F	value

Notes:

1. Since Result Registers follow State Registers for interrupt transfers, the register offset starting value shown in Table 16 for Result Registers follows the last value of Table 15 State Registers.
2. The number of Result Register bytes returned will vary depending on the number of communication command error conditions encountered or whether an *i*Button device was attached/detected.

DS2490 RESULT REGISTER VALUE DEFINITION Table 17

Data Value Description	Data							
1-Wire Device Detect Byte	0xA5							
Communication Command Error Result	bit7	bit6	bit5	bit4	bit3	bit2	bit1	bit0
	EOS	RDP	CRC	CMP	VPP	APP	SH	NRS
	<p>Bit Definitions:</p> <p>EOS A value of 1 indicates that a SEARCH ACCESS with SM=1 ended sooner than expected reporting less ROM Ids than specified in the “number of devices” parameter.</p> <p>RDP A value of 1 indicates that a READ REDIRECT PAGE WITH/CRC encountered a page that is redirected.</p> <p>CRC A value of 1 indicates that a CRC error occurred when executing one of the following commands: WRITE SRAM PAGE, WRITE EPROM, READ CRC PROT PAGE, or READ REDIRECT PAGE W/CRC.</p> <p>CMP A value of 1 indicates that there was an error when reading the confirmation byte with a SET PATH command or that the WRITE EPROM command did not program successfully.</p> <p>VPP A value of 1 indicates that during a PULSE with TYPE=1 or WRITE EPROM command the 12V programming pulse was not seen on the 1-Wire bus; this could indicate that there were other devices on the bus that clamped the voltage to a value lower than VPP or that the programming pulse was disabled with a mode command.</p> <p>APP A value of 1 indicates that a 1-WIRE RESET revealed an Alarming Presence Pulse.</p> <p>SH A value of 1 indicates that a 1-WIRE RESET revealed a short to the 1-Wire bus or the SET PATH command could not successfully connect a branch due to a short.</p> <p>NRS A value of 1 indicates that a 1-WIRE RESET did not reveal a Presence Pulse or the SET PATH command did not get a Presence Pulse from the branch that was to be connected.</p> <p>A value of 0 in any of these fields indicates that the error condition was not detected.</p>							

USB TRANSCEIVER

Integrated within the DS2490 is a USB-compliant bus transceiver. To comply with USB cable termination requirements, resistors external to the DS2490 must be installed as shown in Figure 11. The 24-ohm, 1% tolerance resistors are necessary to bring the total steady state resistance of each driver to the 28-43 ohm range required by the USB core specification. The 1.5 kohm pullup resistor is required to

identify the DS2490 as a high speed USB device to the up-stream HUB. The 33 pF capacitors are optional but are useful for edge rate control and for bypassing high frequency energy to ground for EMI reduction purposes.

USB Transceiver Termination Figure 11

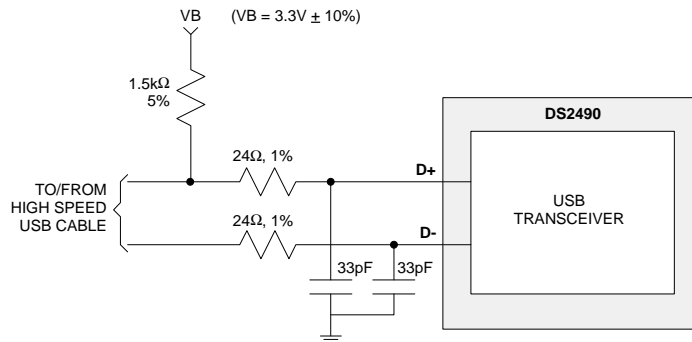

SUSPEND OUTPUT

Suspend output signal (SUSO) operation is a function of both the USB device state of the DS2490 (configured or unconfigured) and the USB suspend state. A truth table for signal operation is listed in Table 18. This signal could be used stand-alone or combined with other external signals to power down circuitry external to the DS2490, such as power sources. The SUSO signal is an open drain output and requires an external pullup to a positive supply no greater than 6.0V.

Suspend Output Operation Table 18

Device State	Suspend State	<u>SUSO</u>
unconfigured	don't care	high
configured	not suspended	low
configured	suspended	high

OSCILLATOR

The DS2490 requires a single 12.0 MHz crystal or crystal oscillator clock source to operate. Crystals or CMOS crystal oscillators may be used to provide clock sources. For crystals, use parallel resonant, fundamental mode with a CL specification between 10 pF and 20 pF at the required frequency. Parallel loading capacitors with a value of approximately twice CL are also required. The connection scheme shown in Figure 12 should be used. For external CMOS crystal oscillators, make a connection directly to the DS2490 XI input. The XO output must be left floating for this arrangement.

Oscillator Connection Figure 12

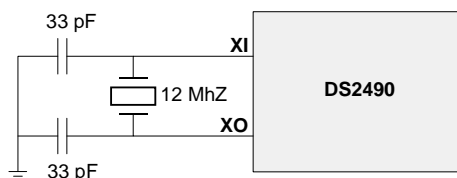

ABSOLUTE MAXIMUM RATINGS*

Voltage on Any Pin Relative to Ground	-0.5V to +7.0V
Operating Temperature	0 °C to +70 °C
Storage Temperature	-55 °C to +125 °C
Soldering Temperature	260 °C for 10 seconds

- This is a stress rating only and functional operation of the device at these or any other conditions above those indicated in the operation sections of this specification is not implied. Exposure to absolute maximum rating conditions for extended periods of time may affect reliability.

RECOMMENDED DC OPERATING CONDITIONS

PARAMETER	SYMBOL	MIN	TYP	MAX	UNITS	NOTES
USB I/F Supply Voltage	VB	3.0	3.3	3.6	V	1, 3
Digital Supply Voltage	VD	4.4	5.0	5.5	V	1, 3
EPROM Programming Supply Voltage (programming supported)	VPP	11.75	12.0	12.25	V	1, 3
EPROM Programming Supply Voltage (programming not supported)	VPP	4.4	5.0	5.5	V	1, 2, 3
Input Logic 0	VIL	-0.3		0.3	V	1
Input Logic 1	VIH	2.8		VD + 0.3	V	1
Operating Temperature	TA	0	25	70	°C	

NOTES:

1. Voltage referenced to ground.
2. When EPROM programming is not supported VPP must be tied to VD.
3. During device power-up, the supply application sequence order must be VD, VPP, VB.

DC ELECTRICAL CHARACTERISTICS

TA: 0 °C - 70 °C
VD: 4.4V - 5.5V, VB:3.0V - 3.6V

PARAMETER	SYMBOL	MIN	TYP	MAX	UNITS	NOTES
VD Operating Current	ID			tbd	mA	4
VB Operating Current	IB			tbd	mA	4
Idle Current on VPP	IPP		20		µA	1
Active Pullup Timer Threshold	VIAPTO	VD-1.4	VD-1.1		V	
Active Pullup On Threshold	VIAPO		0.95	1.2	V	
1-Wire Input High	VIHI	3.4			V	
1-Wire Input Low	VILI			1.8	V	
1-Wire Weak Pullup Current	IWEAKPU	1.8	3.0	5.0	mA	
1-Wire Active Pullup current	IACTPU	9	15		mA	
Strong Pullup Voltage Drop	ΔVSTRPU			0.5	V	2

PARAMETER	SYMBOL	MIN	TYP	MAX	UNITS	NOTES
@ 50 mA load on 1-Wire						
Programming Voltage Drop @ 10 mA load on 1-Wire	ΔV_{PROG}			0.24	V	3
Power On Reset Trip Point	V_{POR}			3.3	V	
VPP Sensor Trip Point	V_{PPTrip}		9.08		V	

NOTES:

1. Applies only if 12.0V VPP supply is connected. If VPP and VD are tied together, current is less than 1 μA .
2. Voltage difference between VD and 1-WIRE.
3. Voltage difference between VPP and 1-WIRE.
4. The sum of ID and IB will not exceed 50 mA.

AC CHARACTERISTICS CONDITIONS:

TA: 0 °C - 70 °C
VD: 4.4V - 5.5V, VB: 3.0V - 3.6V

PARAMETER	SPECIFICATION
USB I/F	As defined in Chapter 7 of the USB Specification
1-Wire I/F	See the section "1-WIRE INTERFACE CONTROLLER" of this document

CAPACITANCE CONDITIONS:

TA: 25 °C

PARAMETER	SYMBOL	MIN	TYP	MAX	UNITS	NOTES
Input Capacitance	CIN			15	pF	
Output Capacitance	COU			15	pF	
Input/Output Capacitance	CIO			15	pF	

HW/SW APPLICATION RECOMMENDATIONS

A schematic example of a USB to 1-Wire Adapter peripheral is shown in Figure 13.

Software application recommendations – TBA.

When using the DS2490 to communicate with the Crypto-1-Wire or devices which require large data transfers, it is suggested that the FIFO for Endpoint 2 (128 bytes) be filled with data before starting the Communication command which will be responsible for the transmission to the 1-Wire bus. Once the command is started and if more data than the initial 128 bytes is to be sent, the Endpoint 2 FIFO status must be monitored via EP1 state registers. Additional data must not be sent until there is less than 64 bytes remaining in the Endpoint 2 FIFO. Operating in this fashion will keep the 1-Wire bus from becoming idle during large data transfers to the 1-Wire device as well as minimizing the USB bandwidth consumed by the DS2490.

HW DESIGN EXAMPLE: USB TO 1-WIRE ADAPTER Figure 13

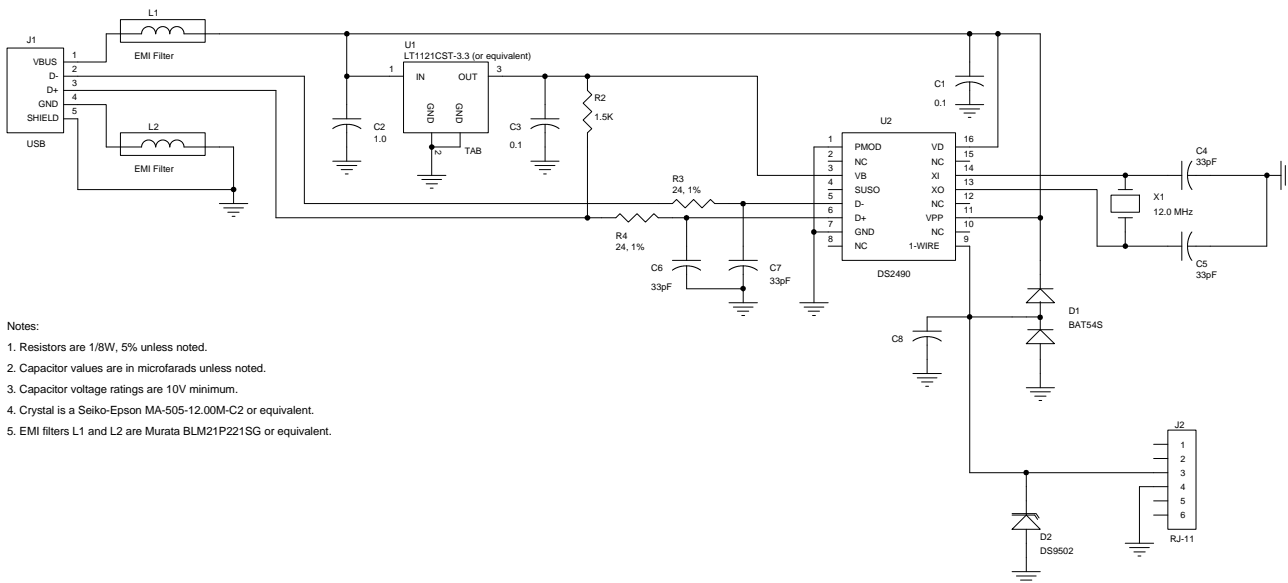

- Notes:
1. Resistors are 1/8W, 5% unless noted.
 2. Capacitor values are in microfarads unless noted.
 3. Capacitor voltage ratings are 10V minimum.
 4. Crystal is a Seiko-Epson MA-505-12.00M-C2 or equivalent.
 5. EMI filters L1 and L2 are Murata BLM21P221SG or equivalent.

APPENDIX 1: DS2490 CONTROL COMMANDS, SETUP PACKET ENCODING

CONTROL COMMANDS	
RESET DEVICE	
Setup Packet Encoding:	
bmRequestType	0x40
bRequest	CONTROL_CMD
wValue	CTL_RESET_DEVICE
wIndex	0x0000
wLength	0x0000
START EXECUTION	
Setup Packet Encoding:	
bmRequestType	0x40
bRequest	CONTROL_CMD
wValue	CTL_START_EXE
wIndex	0x0000
wLength	0x0000
RESUME EXECUTION	
Setup Packet Encoding:	
bmRequestType	0x40
bRequest	CONTROL_CMD
wValue	CTL_RESUME_EXE
wIndex	0x0000
wLength	0x0000
HALT EXECUTION WHEN IDLE	
Setup Packet Encoding:	
bmRequestType	0x40
bRequest	CONTROL_CMD
wValue	CTL_HALT_EXE_IDLE
wIndex	0x0000
wLength	0x0000
HALT EXECUTION WHEN DONE	
Setup Packet Encoding:	
bmRequestType	0x40
bRequest	CONTROL_CMD
wValue	CTL_HALT_EXE_DONE
wIndex	0x0000

CONTROL COMMANDS	
wLength	0x0000
CANCEL COMMAND	
Setup Packet Encoding:	
bmRequestType	0x40
bRequest	CONTROL_CMD
wValue	CTL_CANCEL_CMD
wIndex	0x0000
wLength	0x0000
CANCEL MACRO	
Setup Packet Encoding:	
bmRequestType	0x40
bRequest	CONTROL_CMD
wValue	CTL_CANCEL_MACRO
wIndex	0x0000
wLength	0x0000
FLUSH COMM CMDS	
The DS2490 must be in a halted state before the FLUSH COMM CMDS command can be processed.	
Setup Packet Encoding:	
bmRequestType	0x40
bRequest	CONTROL_CMD
wValue	CTL_FLUSH_COMM_CMDS
wIndex	0x0000
wLength	0x0000
FLUSH DATA RCV BUFFER	
The DS2490 must be in a halted state before the FLUSH DATA RCV BUFFER command can be processed.	
Setup Packet Encoding:	
bmRequestType	0x40
bRequest	CONTROL_CMD
wValue	CTL_FLUSH_RCV_BUFFER
wIndex	0x0000
wLength	0x0000
FLUSH DATA XMT BUFFER	
The DS2490 must be in a halted state before the FLUSH DATA XMT BUFFER command can be processed.	
Setup Packet Encoding:	
bmRequestType	0x40
bRequest	CONTROL_CMD
wValue	CTL_FLUSH_XMT_BUFFER

CONTROL COMMANDS	
wIndex	0x0000
wLength	0x0000
GET COMM CMDS	
The DS2490 must be in a halted state before the GET COMM CMDS command can be processed.	
Setup Packet Encoding:	
bmRequestType	0xC0
bRequest	CONTROL_CMD
wValue	CTL_GET_COMM_CMDS
wIndex	0x0000
wLength	variable
	The value of the wLength field depends on the number of communication commands and parameters loaded in the FIFO.

APPENDIX 2: DS2490 COMMUNICATION COMMANDS, EMBEDDED COMMAND BITS, SETUP PACKET ENCODING.

Communication commands contain embedded command parameter bits in the wValue field. The definitions of bit parameters are described below.

BIT NAME	DESCRIPTION
CH	CH=1 follows the chain if the page is redirected. CH=0 stops reading if the page is redirected.
CIB	CIB=1 prevents a strong pullup to 5V if SPU=1 and the bit read back from the 1-Wire bus is 1. CIB=0 generally enables the strong pullup to 5V.
PS	PS=1 reduces the preamble size to 2 bytes (rather than 3). PS=0 sets preamble size to 3 bytes.
D	Data bit value to be written to the 1-Wire bus.
DT	DT=1 activates/selects the CRC16 generator DT=0 specifies no CRC.
F	F=1 clears the buffers in case an error occurred during the execution of the previous command; requires that ICP=0 in the previous command. F=0 prevents the buffers from being cleared.
ICP	ICP=1 indicates that the command is not the last one of a macro; as a consequence error feedback messages are suppressed. ICP=0 indicates that the command is the last one of a macro or single command operation; enables error feedback signaling.
IM	IM=1 enables immediate execution of the command. Assumes that all 1-Wire device data required by the command has been received at EP2. IM=0 prevents immediate execution of the command; execution must be started through a control function command.
PST	PST=1 continuously generate 1-Wire Reset sequences until a presence pulse is discovered. PST=0 generate only one 1-Wire Reset sequence.
R	R=1 performs a read function. R=0 performs a write function.
RST	RST=1 inserts a 1-Wire Reset before executing the command. RST=0 no 1-Wire Reset inserted.
RTS	RTS=1 returns the discrepancy information to the host if SM=1 and there are more devices than could be discovered in the current pass. RTS=0 does not return discrepancy information.
SE	SE=1 enable the speed change on the 1-Wire bus. SE=0 disable the speed change on the 1-Wire bus.
SM	SM=1 searches for and reports ROM Ids without really accessing a particular device. SM=0 makes a "Strong Access" to a particular device.
SPU	SPU=1 inserts a strong pullup to 5V after a Bit or Byte or Block I/O or Do & Release command. SPU=0 no strong pullup.

TYPE	TYPE=1 specifies programming pulse duration. TYPE=0 specifies strong pullup duration.
Z	Z=1 checks if the 0-bits in the byte to be written are 0-bits in the byte read back from the device. Z=0 checks if the byte to be written is identical to the one read back from the device.

COMMUNICATION COMMANDS

ERROR ESCAPE	If an error condition was detected, host intervention is required to recover from the ERROR ESCAPE state. If no error occurred, the command is processed as a NO OPERATION.									
Setup Packet Encoding:										
bmRequestType	0x40									
bRequest	COMM_CMD									
wValue	byte 2					byte 1				
	byte 2:	0	0	0	0	F	1	1	RST	
	byte 1:	0	0	0	0	0	0	0	1	
wIndex	0x0000									
wLength	0x0000									
SET DURATION										
Setup Packet Encoding:										
bmRequestType	0x40									
bRequest	COMM_CMD									
wValue	byte 2					byte 1				
	byte 2:	0	0	0	0	0	0	ICP	0	
	byte 1:	0	0	0	1	TYPE	0	1	IM	
wIndex	byte 2					byte 1				
	byte 2 – 0x00 (unused)									
	byte 1 – new duration: Unsigned 8-bit binary number specifying the new duration. See MODE CONTROL section for byte bit weighting and additional format information.									
wLength	0x0000									
PULSE										
Setup Packet Encoding:										
bmRequestType	0x40									
bRequest	COMM_CMD									
wValue	byte 2					byte 1				
	byte 2:	0	0	0	0	F	0	ICP	0	
	byte 1:	0	0	1	1	TYPE	0	0	IM	
wIndex	0x0000									
wLength	0x0000									

COMMUNICATION COMMANDS

1-WIRE RESET									
Setup Packet Encoding:									
bmRequestType	0x40								
bRequest	COMM_CMD								
wValue	byte 2					byte 1			
	byte 2:	0	PST	0	0	F	0	ICP	0
	byte 1:	0	1	0	0	SE	0	1	IM
wIndex	byte 2					byte 1			
	byte 2 – 0x00 (unused)								
	byte 1 – new speed: 0x02 with SE=1 after Overdrive Skip ROM 0x01 or 0x00 with SE=1 in all other cases don't care with SE=0								
wLength	0x0000								
BIT I/O									
Setup Packet Encoding:									
bmRequestType	0x40								
bRequest	COMM_CMD								
wValue	byte 2					byte 1			
	byte 2:	0	CIB	0	SPU	0	0	ICP	0
	byte 1:	0	0	1	0	D	0	0	IM
wIndex									
wLength	0x0000								
BYTE I/O									
Setup Packet Encoding:									
bmRequestType	0x40								
bRequest	COMM_CMD								
wValue	byte 2					byte 1			
	byte 2:	0	0	0	SPU	0	0	ICP	0
	byte 1:	0	1	0	1	0	0	1	IM
wIndex	byte 2					byte 1			
	byte 2 – 0x00 (unused)								
	byte 1 – data byte to be sent to the 1-Wire bus. To read only, the byte should be 0xFF.								
wLength	0x0000								
BLOCK I/O									
Setup Packet Encoding:									

COMMUNICATION COMMANDS									
bmRequestType	0x40								
bRequest	COMM_CMD								
wValue	byte 2				byte 1				
	byte 2:	0	0	0	SPU	0	0	ICP	RST
	byte 1:	0	1	1	1	0	1	0	IM
wIndex	byte 2				byte 1				
	byte 2 – block size (HI), most significant byte								
	byte 1 – block size (LOW), least significant byte								
wLength	0x0000								
MATCH ACCESS									
Setup Packet Encoding:									
bmRequestType	0x40								
bRequest	COMM_CMD								
wValue	byte 2				byte 1				
	byte 2:	0	0	0	0	0	0	ICP	RST
	byte 1:	0	1	1	0	SE	1	0	IM
wIndex	byte 2				byte 1				
	byte 2 – new speed: 0x02 with SE=1 after Overdrive Skip ROM 0x01 or 0x00 with SE=1 in all other cases don't care with SE=0								
	byte 1 – 1-Wire command: Command to be used for addressing a 1-Wire device. Valid codes: 0x55 (Match ROM) 0x69 (Overdrive Match ROM)								
wLength	0x0000								
READ STRAIGHT									
Setup Packet Encoding:									
bmRequestType	0x40								
bRequest	COMM_CMD								
wValue	byte 2				byte 1				
	byte 2:	Preamble size. Number of bytes to be written.							
	byte 1:	1	0	0	0	0	ICP	RST	IM
wIndex	byte 2				byte 1				
	byte 2 – Block size HI. Number of bytes to be read, most significant byte.								
	byte 1 - Block size LOW. Number of bytes to be read, least significant byte.								
wLength	byte 2				byte 1				
	byte 2 – 0x00 (not used)								

COMMUNICATION COMMANDS									
	byte 1 – Preamble size. Number of bytes to be written.								
DO & RELEASE									
Setup Packet Encoding:									
bmRequestType	0x40								
bRequest	COMM_CMD								
wValue	byte 2					byte 1			
	byte 2:	0	1	1	SPU	F	0	ICP	0
	byte 1:	1	0	0	1	R	0	1	IM
wIndex	byte 2					byte 1			
	byte 2 – 0X00 (unused)								
	byte 1 – size in bytes of preamble to be written.								
wLength	0x0000								
SET PATH									
Setup Packet Encoding:									
bmRequestType	0x40								
bRequest	COMM_CMD								
wValue	byte 2					byte 1			
	byte 2:	0	0	0	0	F	0	ICP	RST
	byte 1:	1	0	1	0	0	0	1	IM
wIndex	byte 2					byte 1			
	byte 2 – 0X00 (unused)								
	byte 1 – size in bytes of number of couplers that need to be activated to set up the path to the target device.								
wLength	0x0000								
WRITE SRAM PAGE									
DT=1 activates the CRC16 generator. This command is also applicable to the Write IPR and Write I/O Buffer function of the crypto iButton if CIB=1. To write a partial page the page size parameter and the target address need to be set accordingly.									
Setup Packet Encoding:									
bmRequestType	0x40								
bRequest	COMM_CMD								
wValue	byte 2					byte 1			
	byte 2:	0	PS	DT	0	F	0	ICP	0
	byte 1:	1	0	1	1	0	0	1	IM
wIndex	byte 2					byte 1			
	byte 2 – 0X00 (unused)								
	byte 1 – number of bytes to be sent to the device following a 3 byte preamble. This number is typically identical to the page size. A value of 0x00 stands for a 256 byte page.								

COMMUNICATION COMMANDS									
wLength	0x0000								
WRITE EPROM	DT=1 selects the CRC16 generator. Otherwise an 8-bit CRC is assumed. If Z=1 the comparison of the byte read back for verification is limited to 0 bits only.								
Setup Packet Encoding:									
bmRequestType	0x40								
bRequest	COMM_CMD								
wValue	byte 2				byte 1				
	byte 2:	0	0	DT	0	F	0	ICP	0
	byte 1:	1	1	0	0	Z	1	0	IM
wIndex	byte 2				byte 1				
	byte 2 – block size (HI), number of bytes to be written, most significant byte								
	byte 1 – block size (LOW), number of bytes to be written, least significant byte								
wLength	0x0000								
READ CRC PROT PAGE	DT=1 selects the CRC16 generator, otherwise an 8-bit CRC is assumed. This command is also applicable to the Read IPR and Read I/O Buffer function of the crypto <i>i</i> Button if CIB=1.								
Setup Packet Encoding:									
bmRequestType	0x40								
bRequest	COMM_CMD								
wValue	byte 2				byte 1				
	byte 2:	0	PS	DT	0	F	0	ICP	0
	byte 1:	1	1	0	1	0	1	0	IM
wIndex	byte 2				byte 1				
	byte 2 –number of pages to be read.								
	byte 1 – page size: number of bytes that are considered a page. Typical is 32-decimal for data memory, 8 for status memory, and 40 decimal for Monetary <i>i</i> Buttons. Page size 0 indicates a 256-byte page.								
wLength	0x0000								
READ REDIRECT PAGE W/CRC									
Setup Packet Encoding:									
bmRequestType	0x40								
bRequest	COMM_CMD								
wValue	byte 2				byte 1				
	byte 2:	0	0	1	0	F	0	ICP	1

COMMUNICATION COMMANDS									
	byte 1:	1	1	1	0	CH	1	0	IM
wIndex	byte 2					byte 1			
	byte 2 - page number to be used for the first read attempt.								
	byte 1 - page size: number of bytes that are considered a page. Typical is 32 decimal for data memory. Page size 0 indicates a 256-byte page.								
wlength	0x0000								
SEARCH ACCESS									
Setup Packet Encoding:									
bmRequestType	0x40								
bRequest	COMM_CMD								
wValue	byte 2					byte 1			
	byte 2:	0	RTS	0	0	F	0	ICP	RST
	byte 1:	1	1	1	1	SM	1	0	IM
wIndex	byte 2					byte 1			
	byte 2 - number of devices. Maximum number of devices to be discovered in a single command call. A value of 0x00 indicates that all devices on the MicroLAN are to be discovered.								
	byte 1 - 1-Wire command: Command to be used for addressing a 1-Wire device. Valid codes: 0xF0 (Search ROM) 0xEC (Conditional Search ROM)								
wLength	0x0000								

APPENDIX 3: DS2490 MODE COMMANDS, SETUP PACKET ENCODING

MODE COMMANDS									
ENABLE PULSE									
Setup Packet Encoding:									
bmRequestType	0x40								
bRequest	MODE_CMD								
wValue	MOD_PULSE_EN								
wIndex	byte 2				byte 1				
	byte 2 – 0x00								
	byte 1:	0	0	0	0	0	0	SPUE	PRGE
	Strong pullup is enabled with SPUE=1, disabled with SPUE=0. +12V Programming pulse is enabled with PRGE=1, disabled with PRGE=0.								
wLength	0x0000								
ENABLE SPEED CHANGE									
Setup Packet Encoding:									
bmRequestType	0x40								
bRequest	MODE_CMD								
wValue	MOD_SPEED_CHANGE_EN								
wIndex	byte 2				byte 1				
	byte 2 – 0x00								
	byte 1 – Boolean value. Speed changes are enabled with TRUE, disabled with FALSE.								
wLength	0x0000								
1-WIRE SPEED									
Setup Packet Encoding:									
bmRequestType	0x40								
bRequest	MODE_CMD								
wValue	MOD_1WIRE_SPEED								
wIndex	byte 2				byte 1				
	byte 2 – 0x00								
	byte 1 – 1-Wire speed: Code specifying communication speed of the 1-Wire bus. See MODE CONTROL section for code definition.								
wLength	0x0000								
STRONG PULLUP DURATION									
Setup Packet Encoding:									

MODE COMMANDS		
bmRequestType	0x40	
bRequest	MODE_CMD	
wValue	MOD_STRONG_PU_DURATION	
wIndex	byte 2	byte 1
	byte 2 – 0x00	
	byte 1 – Unsigned 8-bit binary number specifying the pullup duration. See MODE CONTROL section for byte bit weighting and additional format information.	
wLength	0x0000	
PULLDOWN SLEW RATE		
Setup Packet Encoding:		
bmRequestType	0x40	
bRequest	MODE_CMD	
wValue	MOD_PULLDOWN_SLEWRATE	
wIndex	byte 2	byte 1
	byte 2 – 0x00	
	byte 1 – Code specifying the typical pulldown slew rate. See MODE CONTROL section for code definition.	
wLength	0x0000	
PROG PULSE DURATION		
Setup Packet Encoding:		
bmRequestType	0x40	
bRequest	MODE_CMD	
wValue	MOD_PROG_PULSE_DURATION	
wIndex	byte 2	byte 1
	byte 2 – 0x00	
	byte 1 – Unsigned 8-bit binary number specifying the EPROM programming pulse duration. See MODE CONTROL section for byte bit weighting and additional format information.	
wLength	0x0000	
WRITE-1 LOW TIME		
Setup Packet Encoding:		
bmRequestType	0x40	
bRequest	MODE_CMD	
wValue	MOD_WRITE1_LOWTIME	
wIndex	byte 2	byte 1
	byte 2 – 0x00	
	byte 1 – Code specifying the Write-1 low time duration. See MODE CONTROL section for code definition.	

MODE COMMANDS	
wLength	0x0000
DSOW0 RECOVERY TIME	
Setup Packet Encoding:	
bmRequestType	0x40
bRequest	MODE_CMD
wValue	MOD_DSOW0_TREC
wIndex	byte 2 byte 1
	byte 2 – 0x00
	byte 1 – Code specifying the recovery time for data sample offset and Write-0. See MODE CONTROL section for code definition.
wLength	0x0000

APPENDIX 4: COMMAND, COMMAND TYPE CONSTANT CODES

COMMAND TYPE CODES	
Name	bRequest
CONTROL_CMD	0x00
COMM_CMD	0x01
MODE_CMD	0x02
TEST_CMD	0x03

CONTROL COMMAND CODES	
Name	wValue
CTL_RESET_DEVICE	0x0000
CTL_START_EXE	0x0001
CTL_RESUME_EXE	0x0002
CTL_HALT_EXE_IDLE	0x0003
CTL_HALT_EXE_DONE	0x0004
CTL_CANCEL_CMD	0x0005
CTL_CANCEL_MACRO	0x0006
CTL_FLUSH_COMM_CMDS	0x0007
CTL_FLUSH_RCV_BUFFER	0x0008
CTL_FLUSH_XMT_BUFFER	0x0009
CTL_GET_COMM_CMDS	0x000A

MODE COMMAND CODES	
Name	wValue
MOD_PULSE_EN	0x0000
MOD_SPEED_CHANGE_EN	0x0001
MOD_1WIRE_SPEED	0x0002
MOD_STRONG_PU_DURATION	0x0003
MOD_PULLDOWN_SLEWRATE	0x0004
MOD_PROG_PULSE_DURATION	0x0005
MOD_WRITE1_LOWTIME	0x0006
MOD_DSOW0_TREC	0x0007