



DS32kHz 32.768kHz Temperature-Compensated Crystal Oscillator

DS32kHz

Crystal Oscillator

www.maxim-ic.com

GENERAL DESCRIPTION

The DS32kHz is a temperature-compensated crystal oscillator (TCXO) with an output frequency of 32.768kHz. This device addresses applications requiring better timekeeping accuracy and can be used to drive the X1 input of most Dallas Semiconductor real-time clocks (RTCs), chipsets, and other ICs containing RTCs. This device is available in commercial (DS32kHz) and industrial (DS32kHz-N) temperature versions.

APPLICATIONS

GPS Receivers
Telematics
Network Timing and Synchronization in Servers,
Routers, Hubs, and Switches
Automatic Power Meters

FEATURES

- Accurate to ± 4 Min/Yr (-40°C to $+85^{\circ}\text{C}$)
- Accurate to ± 1 Min/Yr (0°C to $+40^{\circ}\text{C}$)
- Battery Backup for Continuous Timekeeping
- V_{BAT} Operating Voltage: 2.7V to 5.5V with V_{CC} Grounded
- V_{CC} Operating Voltage: 4.5V to 5.5V
- Operating Temperature Range:
 0°C to $+70^{\circ}\text{C}$ (Commercial)
 -40°C to $+85^{\circ}\text{C}$ (Industrial)
- No Calibration Required
- Low-Power Consumption
- Surface Mountable Using BGA Package
- UL Recognized

ORDERING INFORMATION

PART	TEMP RANGE	PIN-PACKAGE
DS32kHz/DIP	0°C to $+70^{\circ}\text{C}$	14 DIP
DS32kHz-N/DIP	-40°C to $+85^{\circ}\text{C}$	14 DIP
DS32kHz/WBGA	0°C to $+70^{\circ}\text{C}$	36 BGA
DS32kHz-N/WBGA	-40°C to $+85^{\circ}\text{C}$	36 BGA

PIN CONFIGURATIONS

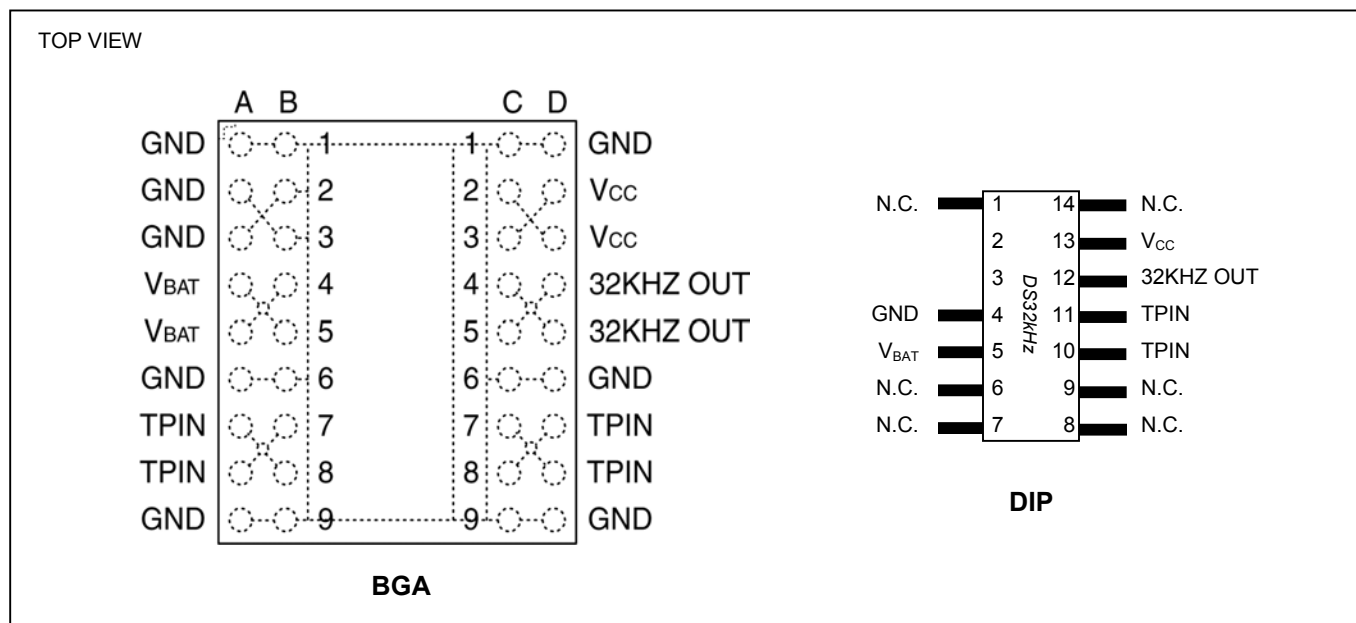

Note: Some revisions of this device may incorporate deviations from published specifications known as errata. Multiple revisions of any device may be simultaneously available through various sales channels. For information about device errata, click here: www.maxim-ic.com/errata.

ABSOLUTE MAXIMUM RATINGS

Voltage Range on Any Pin Relative to Ground	-3.0V to +7.0V
Operating Temperature Range	
Commercial	0°C to +70°C
Industrial	-40°C to +85°C
Storage Temperature Range	-40°C to +85°C
Soldering Temperature (BGA)	See IPC/JEDEC J-STD-020A (2x max) (Note 1)
Soldering Temperature, Leads (DIP)	260°C for 10 seconds (Notes 1, 2)

Stresses beyond those listed under "Absolute Maximum Ratings" may cause permanent damage to the device. These are stress ratings only, and functional operation of the device at these or any other conditions beyond those indicated in the operational sections of the specifications is not implied. Exposure to the absolute maximum rating conditions for extended periods may affect device.

RECOMMENDED DC OPERATING CONDITIONS

($T_A = -40^{\circ}\text{C}$ to $+85^{\circ}\text{C}$)

PARAMETER	SYMBOL	CONDITIONS	MIN	TYP	MAX	UNITS
Power-Supply Voltage	V_{CC}		4.5	5.0	5.5	V
Battery Voltage (Note 3)	V_{BAT}		2.7	3.0	3.3, 5.5	V

DC ELECTRICAL CHARACTERISTICS

(Over the operating range, unless otherwise specified.)

PARAMETER	SYMBOL	CONDITIONS	MIN	TYP	MAX	UNITS
Active Supply Current	I_{CC}	(Notes 4, 5)		150	180	μA
Active Battery Current	I_{BAT}	$V_{CC} = 0\text{V}$, $V_{BAT} = 3.3\text{V}$ (Notes 4, 5, 6, 7)		1	4	μA
High Output Voltage (V_{CC})	V_{OH}	$I_{OH} = -1.0\text{mA}$	2.4			V
Low Output Voltage	V_{OL}	$I_{OL} = 2.1\text{mA}$			0.4	V
Battery Switch Voltage	V_{SW}			V_{BAT}		V
High Output Voltage (V_{BAT})	V_{OH}	$I_{OH} = -0.1\text{mA}$	2.4			V

Note 1: Post-solder cleaning with water-washing techniques is acceptable, provided that ultrasonic vibration is not used. Such cleaning can damage the crystal.

Note 2: Encapsulated DIP modules can be successfully processed through conventional wave-soldering techniques, as long as the temperature of the crystal contained inside does not exceed $+150^{\circ}\text{C}$.

Note 3: V_{BAT} must be no greater than 3.3V when the device is used in the dual-supply operating modes.

Note 4: Typical values are at $+25^{\circ}\text{C}$ and 5.0V V_{CC} , 3.0 V_{BAT} , unless otherwise indicated.

Note 5: These parameters are measured under no load conditions.

Note 6: This current is the active mode current sourced from the backup supply/battery.

Note 7: Battery current increases to 450 μA (typ) for 122ms (typ) for every 64 seconds.

AC TIMING CHARACTERISTICS

(Over the operating range, unless otherwise specified.)

PARAMETER	SYMBOL	CONDITIONS	MIN	TYP	MAX	UNITS
Output Frequency	f_{OUT}			32.768		kHz
Frequency Stability vs. Temperature	$\Delta f/f_0$	0°C to +40°C	-2.0		+2.0	ppm
		-40°C to +85°C or 0°C to +70°C	-7.5		+7.5	
Duty Cycle	t_W/t		45	50	55	%
Cycle Time	t_{CYC}	(Note 8)		30.518		μ s
High/Low Time	t_H/t_L	(Note 8)		15.06		μ s
Rise Time	t_R	(Note 8)		200		ns
Fall Time	t_F	(Note 8)		60		ns
Oscillator Startup Time	t_{OSC}	(Note 8)		1		s
Frequency Stability vs. Operating Voltage	$\Delta f/V$	$V_{CC} = 5.0V$ or $V_{BAT} = 3.0V, V_{CC} = 0V$ (Notes 4, 9)		± 2.5		ppm/V
Crystal Aging	$\Delta f/f_0$	(Notes 4, 10)		± 1.0		ppm/yr

Note 8: These parameters are measured using a 15pF load.

Note 9: Error is measured from the nominal supply voltage of whichever supply is powering the device.

Note 10: After reflow.

TYPICAL OPERATING CHARACTERISTICS

($V_{CC} = 3.3V$, $T_A = +25^\circ C$, unless otherwise noted.)

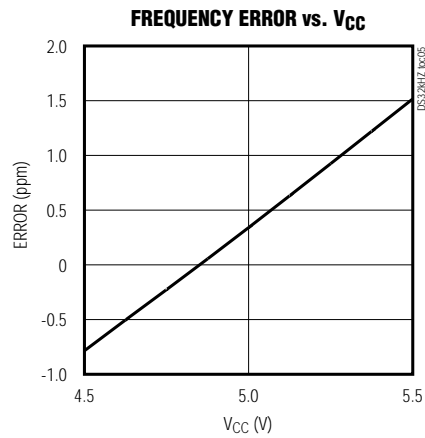
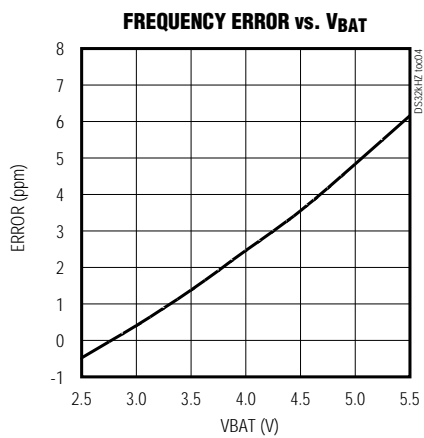
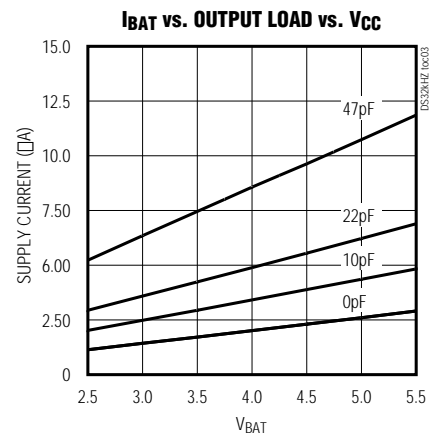
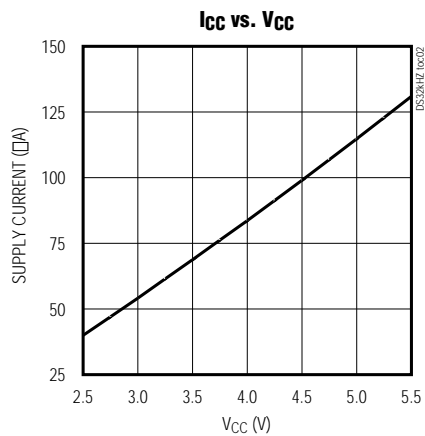
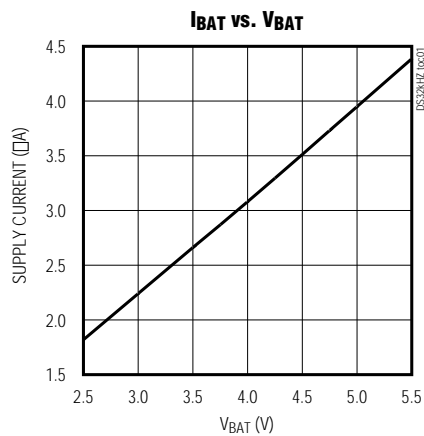

PIN DESCRIPTIONS

PIN		NAME	FUNCTION
BGA	DIP		
A4, A5, B4, B5	5	V _{BAT}	+3V Batttery Supply
A7, A8, B7, B8, C7, C8, D7, D8	10, 11	TPIN	Test Pin (must be grounded)
C2, C3, D2, D3	13	V _{CC}	Primary Power Supply
C4, C5, D4, D5	12	32KHZ OUT	32.768kHz Output
—	1, 6–9, 14	N.C.	No Connection
All remaining balls	4	GND	Ground

Figure 1. Delta Time and Frequency vs. Temperature

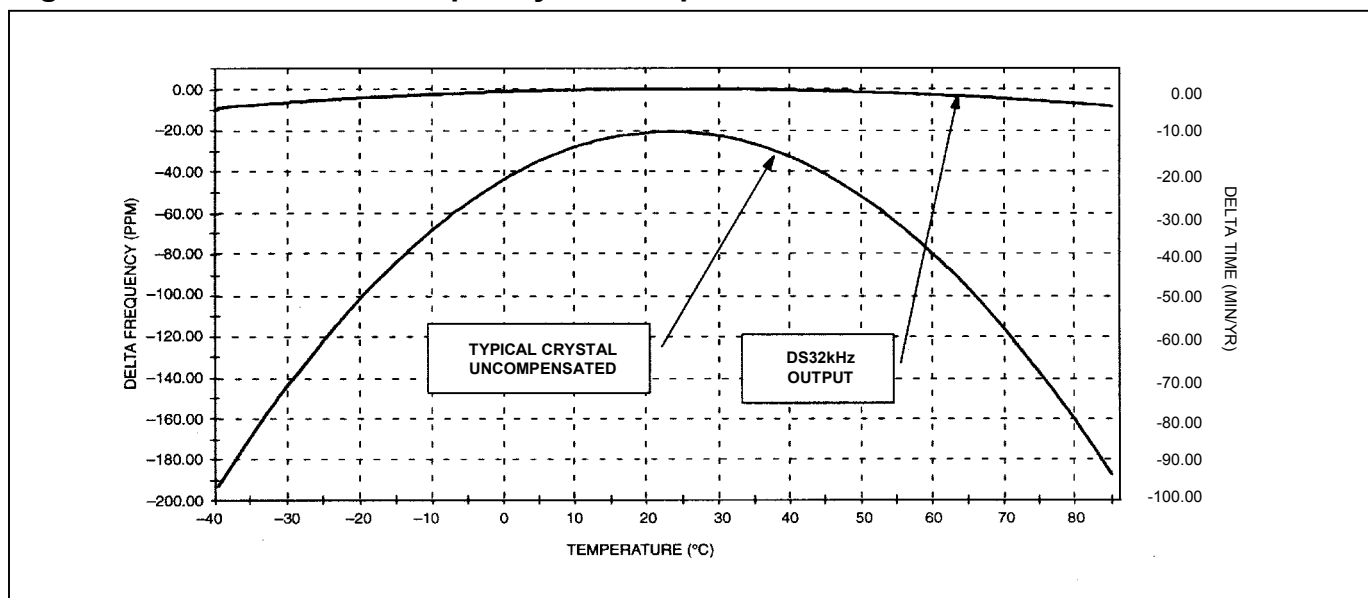

FUNCTIONAL DESCRIPTION

The DS32kHz requires four pins for operation: V_{CC}, GND, V_{BAT}, and 32KHZ OUT. (See Figure 3 for connection schemes.) Power is applied through V_{CC} and GND, while V_{BAT} is used to maintain the 32kHz output in the absence of power. The output is accurate to $\pm 7.5\text{ppm}$ ($\pm 4\text{ min/yr}$) from -40°C to $+85^\circ\text{C}$ and $\pm 2\text{ppm}$ ($\pm 1\text{ min/yr}$) from 0°C to $+40^\circ\text{C}$.

The DS32kHz is packaged in a small 36-pin SMD using ball grid array (BGA) technology with dimensions 0.400" wide, 0.450" long, and 0.124" high. It also is available in a 14-pin DIP module.

The additional board space required is negligible in most applications and, therefore, the recommended land pattern layout should be implemented on all new designs and future board revisions to satisfy applications requiring better timekeeping accuracy.

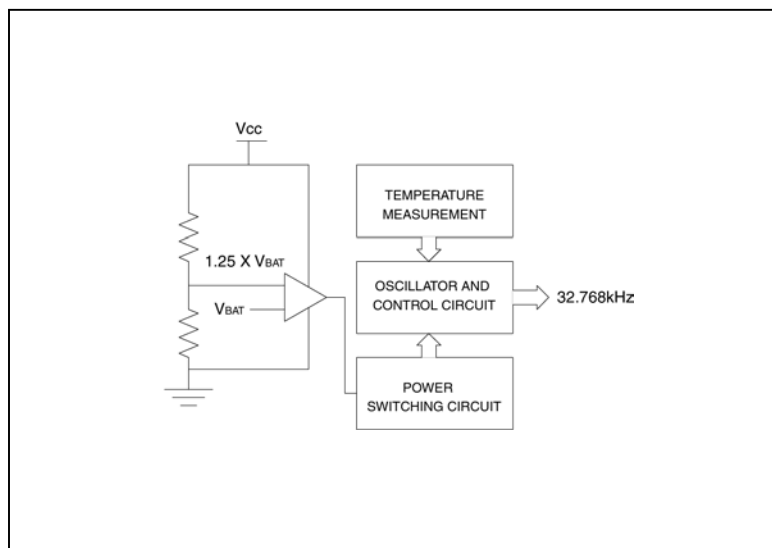
Figure 2. Block Diagram

OPERATION

The DS32kHz module contains a crystal and an IC. While powered, the DS32kHz periodically measures the temperature and adjusts the crystal load to compensate.

The DS32kHz is designed to operate in two modes. In the dual-supply mode, a comparator circuit, powered by V_{CC} , monitors the relationship between the V_{CC} and V_{BAT} input levels. When V_{CC} drops below a certain level compared to V_{BAT} , the device switches over to V_{BAT} (Figure 3A). This mode uses V_{CC} to conserve the battery connected to V_{BAT} while V_{CC} is applied.

In the single-supply mode, V_{CC} is grounded and the unit is powered by V_{BAT} . Current consumption is less than that of V_{CC} , because the comparator circuit is unpowered (Figure 3B).

Figure 3A shows how the DS32kHz should be connected when using two power supplies. V_{CC} should be between 4.5V and 5.5V and V_{BAT} should be between 2.7V and 3.3V. Figure 3B shows how the DS32kHz can be used when only a single-supply system is available. V_{CC} should be grounded and V_{BAT} should then be held between 2.7V and 5.5V. The V_{BAT} pin should be connected directly to a battery. Figure 3C shows a single supply mode where V_{CC} is held at +5V. See the frequency stability versus operating voltage for information about frequency error versus supply voltage.

Figure 3. Power-Supply Connections

Figure 4 illustrates how a standard 32.768kHz crystal and the DS32kHz should be connected to address the interchangeable option. Using this connection scheme and the recommended layout provides a solution, which requires no hardware modifications. Only one device should be used at a time, and both layouts should be located very close together if the recommended layout is not used.

The DS32kHz I_{CC} and I_{BAT} currents are specified with no output loads. Many RTC oscillator circuits use a quartz crystal or resonator. Driving the oscillator circuit with the rail-to-rail output of the DS32kHz can increase the I_{CC} and I_{BAT} currents significantly and increase the current consumption of the RTC as well. Figure 5 shows one circuit that can be used to reduce the current consumption of a DS32kHz and an RTC. The values of R1 and C1 may vary depending on the RTC used. However, values of $1.0M\Omega$ and $100pF$ are recommended as a starting point. R2 is used to shift the input waveform to the proper level. The recommended value for R2 is $33k\Omega$.

Figure 4. DS32kHz Connections

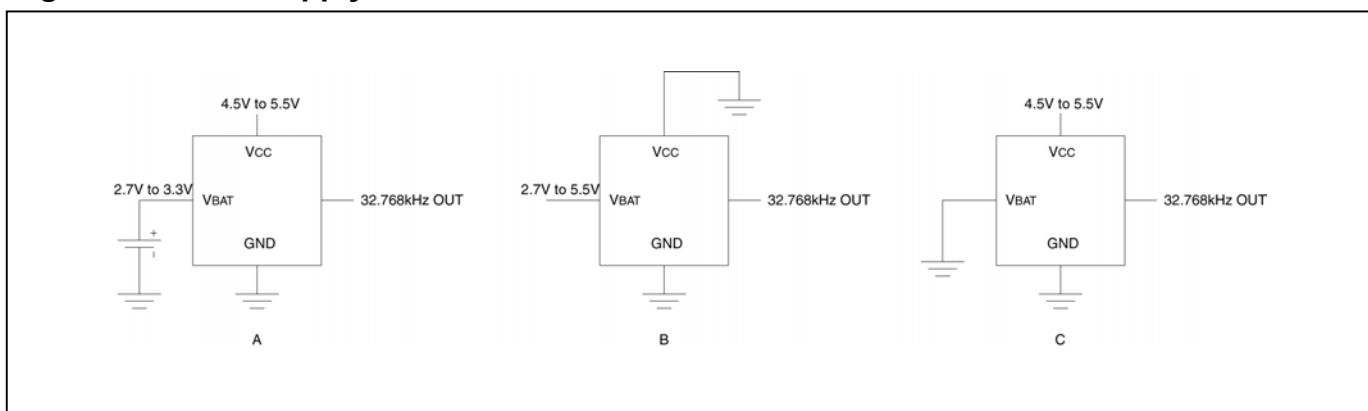
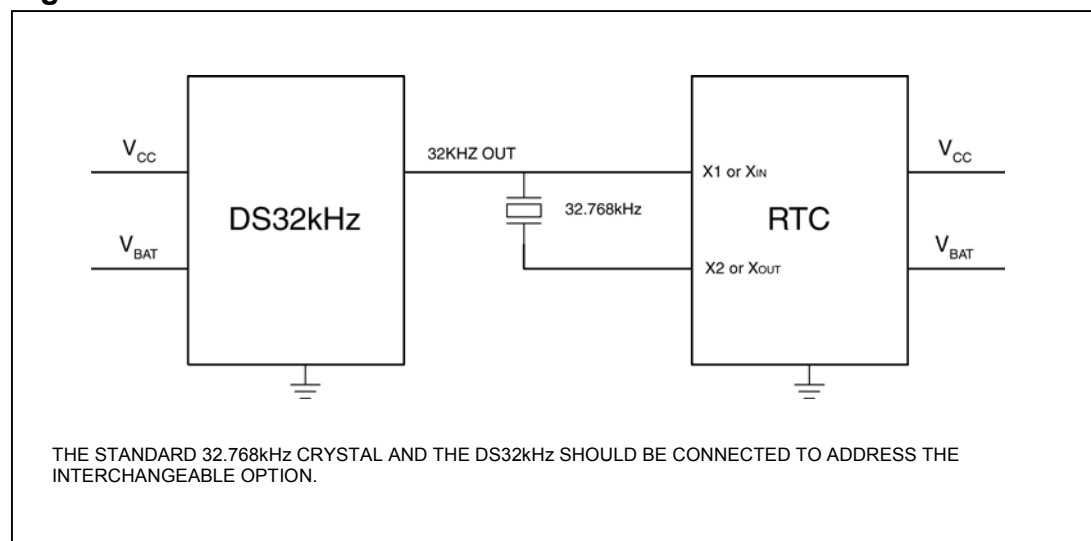

Figure 5. DS32kHz and RTC Connections

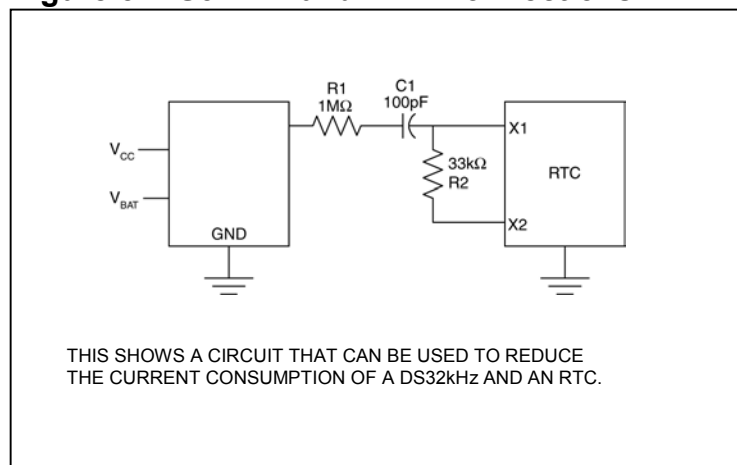
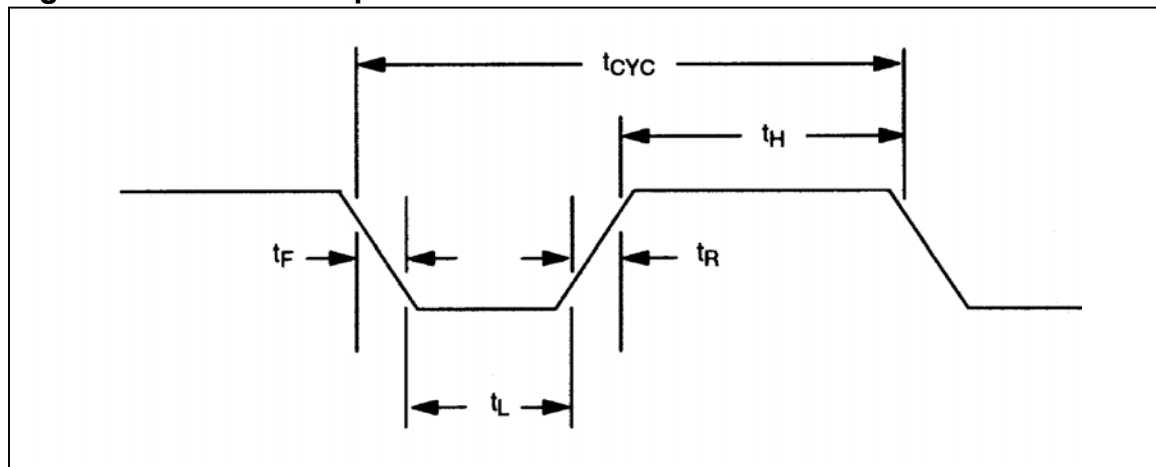

Figure 6. DS32kHz Output Waveform



RELATED APPLICATION NOTES

Application Note 58: *Crystal Considerations with Dallas Real-Time Clocks*

Application Note 701: *Using the DS32kHz with Dallas RTCs*

PACKAGE INFORMATION

(The package drawing(s) in this data sheet may not reflect the most current specifications. For the latest package information, go to www.maxim-ic.com/DallasPackInfo.)

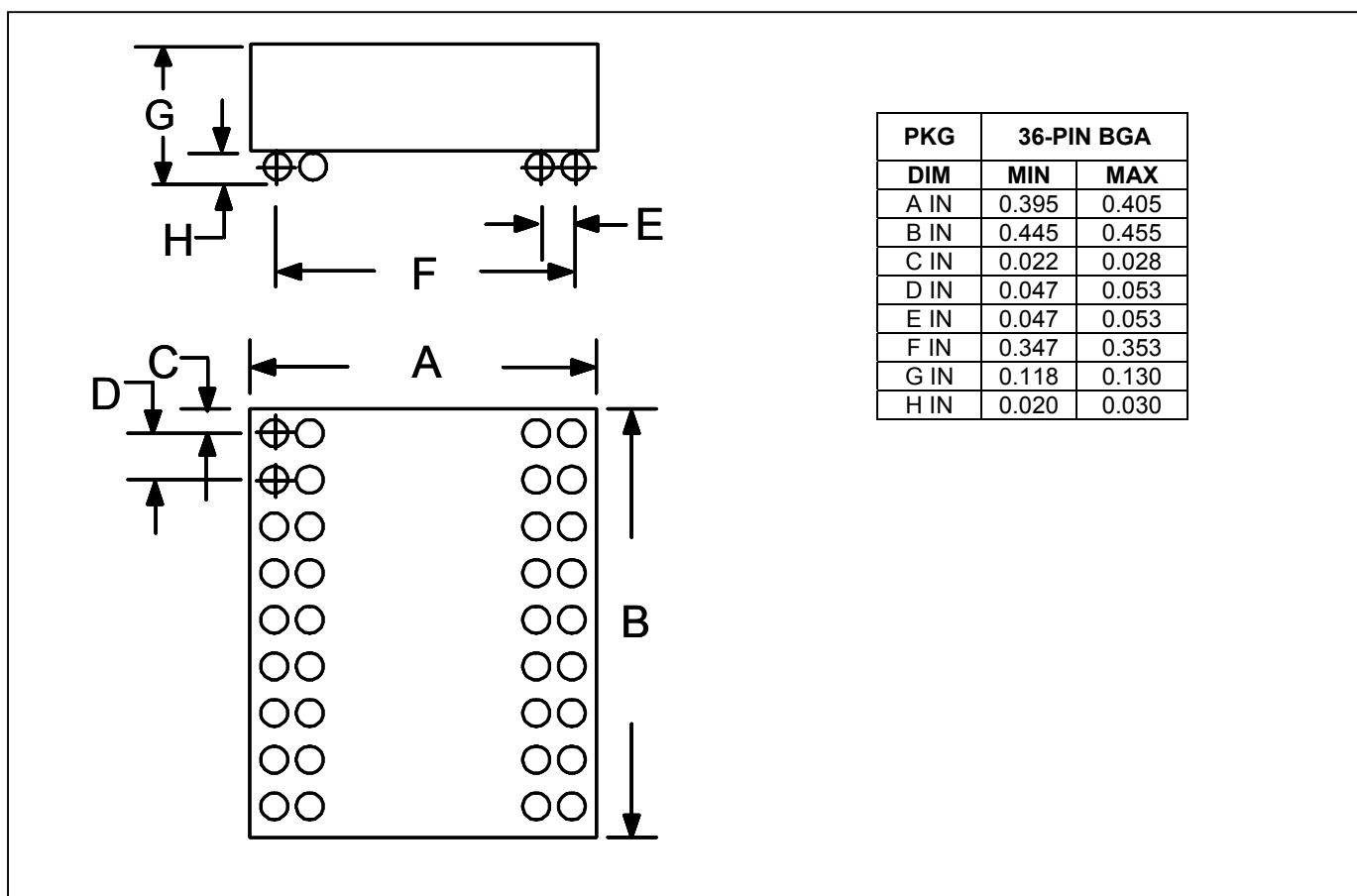

PACKAGE INFORMATION (continued)

(The package drawing(s) in this data sheet may not reflect the most current specifications. For the latest package information, go to www.maxim-ic.com/DallasPackInfo.)

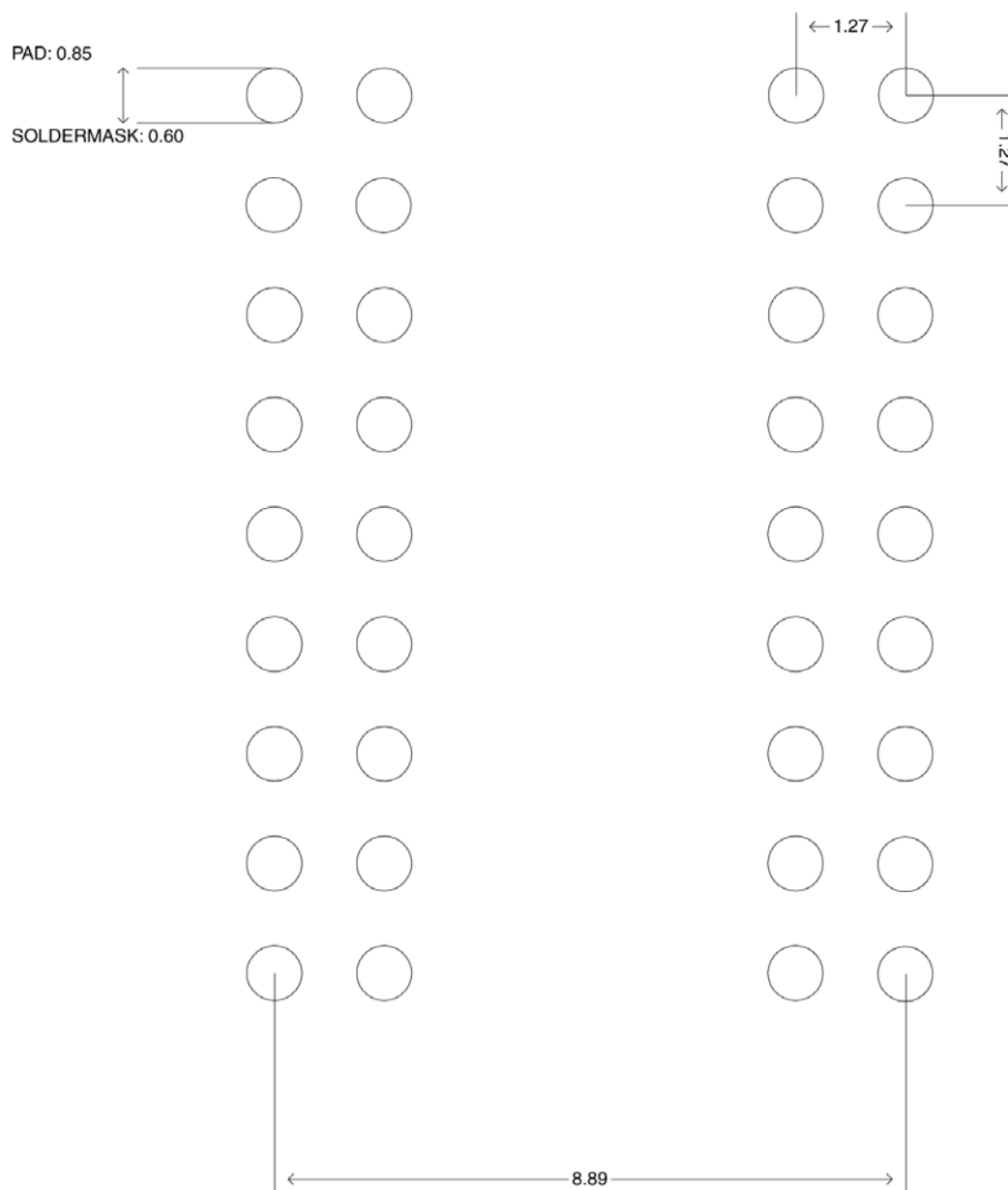
RECOMMENDED LAND PATTERN FOR 36-PIN BGA

Note 1: All dimensions in millimeters.

Note 2: Solder Ball: SnPb 63/37.

Note 3: Solder Ball diameter: 0.762 nominal.

Note 4: BGA has soldermask-defined pads.

PACKAGE INFORMATION (continued)

(The package drawing(s) in this data sheet may not reflect the most current specifications. For the latest package information, go to www.maxim-ic.com/DallasPackInfo.)

