



DATEL
INNOVATION and EXCELLENCE

DMS-30PC-4/20S

4-20mA Input
3½ Digit Panel Meters
with Full-Size LED Displays

New +24V Isolated-Power Models

Order on-line at www.datel.com

Features

- Full-size, 0.56" (14.2mm), red or green LED's
- Low-power or high-intensity LED's optional
- Single +5V or optional +7.5-32V supply
- +24V Isolated-power models
- Low power consumption, 15mA from +5V
- 100W impedance, 2V loop drop
- DIP-switch selectable range and decimal points
- Hundreds of different input/readout combinations
- Vibration-resistant package; Reliable screw-terminal input connections
- High-quality, 20-turn, gain/span and zero/offset adjust potentiometers
- Miniature size: 2.17" x 0.92" x 1.02"
55mm x 23mm x 27mm

The DMS-30PC-4/20S Series of 4-20mA current-loop-input, 3½ digit, LED display panel meters offer an outstanding combination of electrical performance, display readability, ease-of-use, and long-term reliability. Each of the 5 models features a large (0.56"/14.2mm), red or green, LED display. Low-power or high-intensity red models are optional. Power supplies can be a single +5V or an optional, wide-range +7.5-32V (24V nominal). All DMS-30PC-4/20S meters are constructed using DATEL's super-reliable, field-proven, epoxy-encapsulated DMS-30PC digital voltmeters. The entire assembly utilizes 100% soldered connections. These are the most rugged, 4-20mA input, panel meters in the world.

Gain (span) and offset (zero) adjustments are both performed with high-precision, 20-turn potentiometers. All decimal point and range-change settings are made on a gold-plated, vibration-resistant, DIP switch; there are no cumbersome solder gaps or jumpers to contend with. Connections to the current loop and the power source are both made on a rugged, four-position, screw-type terminal block.

The DMS-30PC-4/20S's user-friendly design accommodates virtually hundreds of different input-current/output-reading combinations. This eliminates the majority of requirements for more costly, long-lead-time, factory "specials"—especially in applications requiring several different-range meters. A bezel assembly, featuring secure screw fasteners and an EPDM rubber gasket, is available for applications requiring moisture and/or dust resistance.

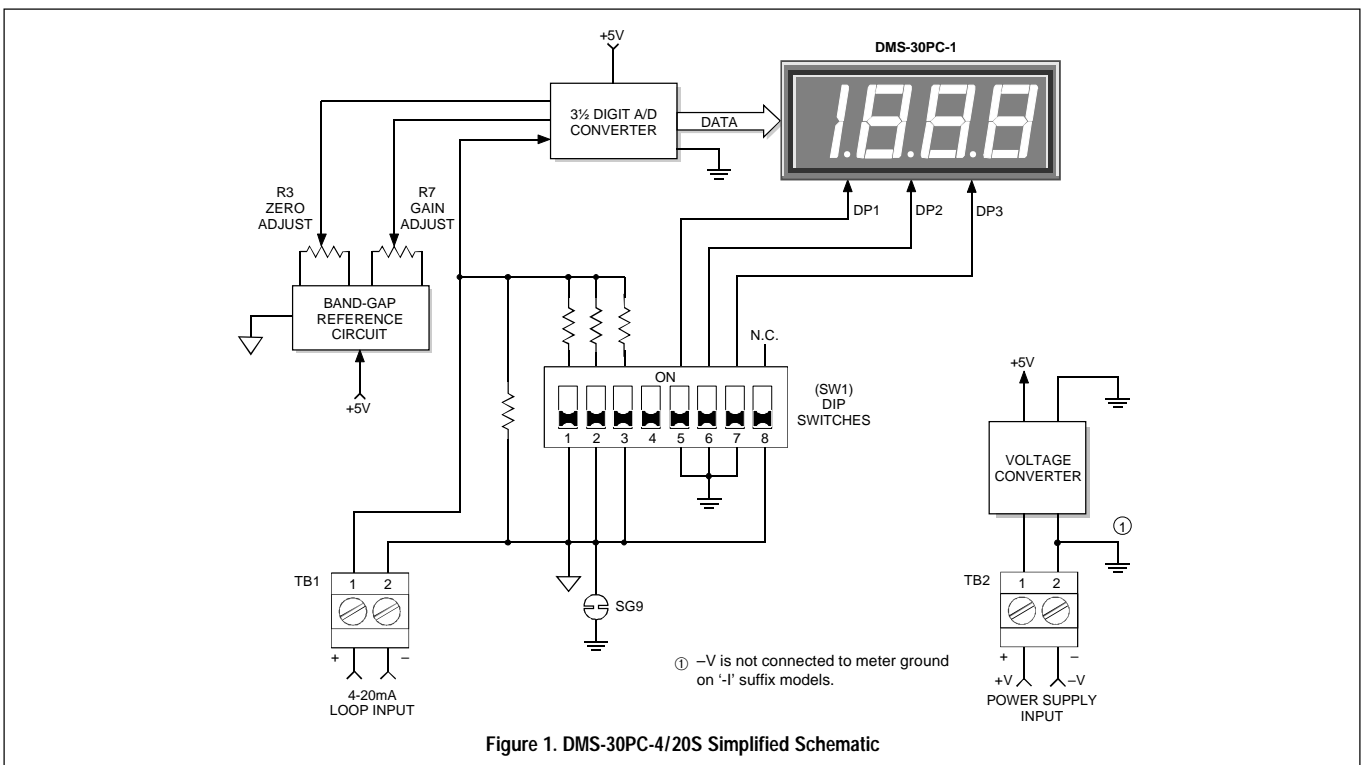

Figure 1. DMS-30PC-4/20S Simplified Schematic

Performance/Functional Specifications

Typical at T_A = +25°C, unless otherwise noted.

Current Loop Input	Min.	Typ.	Max.	Units
Full Scale Input Range	+3.5	--	+22	mA
Input Impedance	--	100	--	Ω
Voltage Drop	--	--	2.0	Volts
Overcurrent Protection	--	--	±40	mA
Performance				
Sampling Rate	2.5 readings per second			
Accuracy (1 minute warm-up)	±0.05%FS ±1 Count			
Temperature Drift (0 to +60°C)	--	±0.15	±0.3	Cnts/°C
Power Supply Requirements ①				
DMS-30PC-4/20S-5RS	+4.75 to +5.25Vdc at 225mA max.			
DMS-30PC-4/20S-5GS	+4.75 to +5.25Vdc at 225mA max.			
DMS-30PC-4/20S-5RH	+4.75 to +5.25Vdc at 225mA max.			
DMS-30PC-4/20S-5RL	+4.75 to +5.25Vdc at 20mA max.			
DMS-30PC-4/20S-24RL	+7.5 to +32Vdc at 30mA max.			
DMS-30PC-4/20S-24RH-I Models	+21.6 to +26.4Vdc at 60mA max.			
Display				
Display Type and Size	3½ digit LED, 0.56"/14.2mm high			
Polarity Indication	"--" for negative readings			
Overrange Indication	"-1___" for negative inputs "1___" for positive inputs			
Physical/Environmental				
Operating Temperature	0	--	+60	°C
Storage Temperature	-40	--	+75	°C
Humidity (Non-condensing)	0	--	95	%
Case Material	Polycarbonate			
Weight	1 ounce (28 grams)			

DIP-Switch Settings Table ②

Display Reading	SW1	SW2	SW3	SW4
1. 000 to 100-300	On	On	On	Off
2. 000 to 400-600	Off	On	Off	Off
3. 000 to 700-1999	On	Off	Off	Off
4. ±100	On	On	On	Off
5. ±200 to ±300	On	On	Off	Off
6. ±400 to ±600	On	Off	Off	Off
7. ±700 to ±1900	Off	Off	Off	On

① **Input Grounding:** Except for the "-I" suffix models which feature isolated current loop inputs, all other DMS-30PC-4/20S meters are supplied with their 4-20mA negative-input terminals (TB1-2, "-") internally connected to their power supply ground terminal (TB2-2, "-V"). This single-ended input configuration is compatible with most grounded-referenced 4-20mA transmitters.

Applications in which the DMS-30PC-4/20S and its associated 4-20mA transmitter are connected to a common ground and the transmitter drives two or more loads (for example, the meter in series with a PLC) must have the meter connected as the **first** device in the current loop, that is, closest to the system ground (see Figure 2). If this is not possible and/or the meter must be connected in the middle of the current loop, then "-I" suffix models **must be used** to provide the required isolation between the meter's current loop input and the power supply ground ("-V"). See Figures 2, 3, 4, and 5 for typical loop connections.

② When looking up DIP-switch settings in the Table and the desired display readings happen to fall between two switch settings, try performing the adjustments with both settings to determine which one offers the better settability. Please keep in mind that the DMS-30PC meter (from which the DMS-30PC-4/20S is derived) has an accuracy specification of ±2 counts (max.). Thus, it may not always be possible to obtain the exact desired display reading.

Order on-line at www.datel.com

Ordering Information

DMS-30PC-4/20S-5RS	+5V supply, standard-intensity red LED's
DMS-30PC-4/20S-5GS	+5V supply, standard-intensity green LED's
DMS-30PC-4/20S-5RL	+5V supply, low-power red LED's
DMS-30PC-4/20S-5RH	+5V supply, high-intensity red LED's
DMS-30PC-4/20S-24RL	+7.5V to +32V supply, low-power red LED's
DMS-30PC-4/20S-24RS-I	+24V isolated supply, standard-intensity red LED's
DMS-30PC-4/20S-24RH-I	+24V isolated supply, high-intensity red LED's
DMS-30PC-4/20S-24GS-I	+24V isolated supply, standard-intensity green LED's
DMS-BZL1	Panel-mount bezel assembly
DMS-BZL2	Panel-mount bezel with sealing gasket
DMS-30-CP	Panel cutout punch

A panel-mount retaining clip is supplied with each model.

Operating and Setup Instructions

As shipped, the DMS-30PC-4/20S is factory calibrated to read "000" for a 4mA input and "1999" for a 20mA input. The following worst-case procedure assumes the DMS-30PC-4/20S is completely mis-adjusted, i.e., both potentiometers and the DIP switches are randomly set.

1. Set R7 (gain/span adjust) and R3 (zero/offset adjust) fully clockwise, roughly 20 turns, and place SW1-SW8 to OFF (down position).
2. Set SW1 to ON (up position). See DIP switch setting #3.
3. Apply a precision 4mA input, with proper polarity, and adjust R3 until the meter's display reads "000".
4. Apply a precision 20mA and adjust R7 until the display reads "1999". Repeat 3 and 4 to make sure adjustments do not affect one another.
5. If desired, select the appropriate decimal point by setting either SW5, SW6 or SW7 to ON (DP1, DP2 or DP3 respectively).

NOTE: If a display reading other than "000" to "1999" is desired, refer to the DIP-Switch Settings Table for SW1-SW4 settings.

Examples

1. Desired display readings are:

4mA = "0.00"
20mA = "2.00"

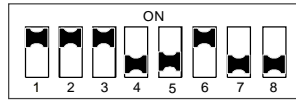

Use DIP-switch setting #1 and enable decimal point DP2 via SW6. Apply 4mA and adjust R3 so the display reads "0.00". Apply 20mA and adjust R7 so the display reads "2.00".

2. Desired display readings are:

4mA = "-100"
12mA = "000"
20mA = "100"

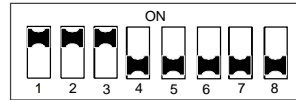

Use DIP-switch setting #4. Apply 12mA and adjust R3 so the display reads "000". Apply 20mA and adjust R7 so the display reads "100".

Apply 4mA and the display should read "-100". For these display readings, no decimal points are used. Set SW5, SW6 and SW7 to OFF.

3. Desired display readings are:

4mA = ".000"
12mA = ".250"

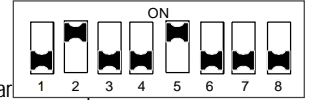

This example is not as straightforward. 12mA is exactly halfway between 4mA and 20mA. If we assume the input could go up to 20mA, the display reading would be: 2 x .250 or ".500". From the table, we can select DIP-switch setting #2 and enable DP1 via SW5. Apply 4mA and adjust R3 so the display reads ".000". Apply 12mA and adjust R7 so the display reads ".250".

CONNECTION DIAGRAMS

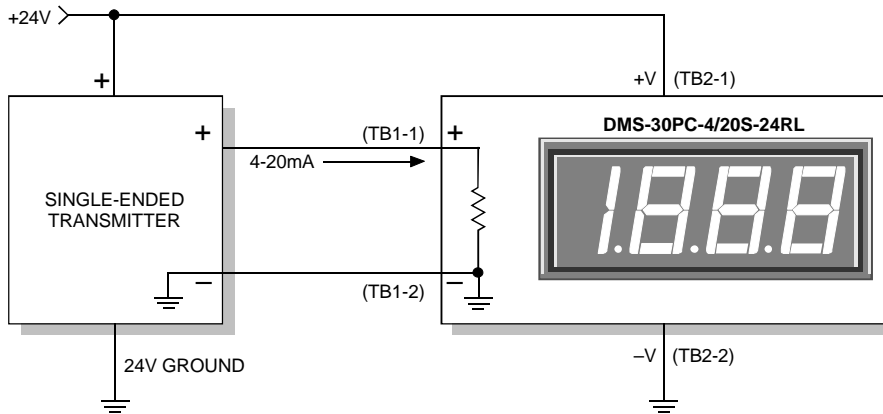

Figure 2. Typical Connections for Single-Ended Transmitters Driving Single-Ended +24V Powered Meters.

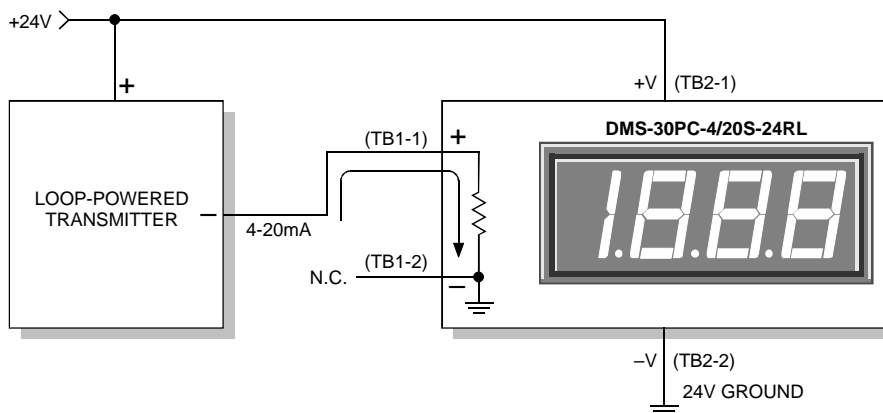

Figure 3. Typical Connections for Loop-Powered Transmitters Driving Single-Ended Meters.

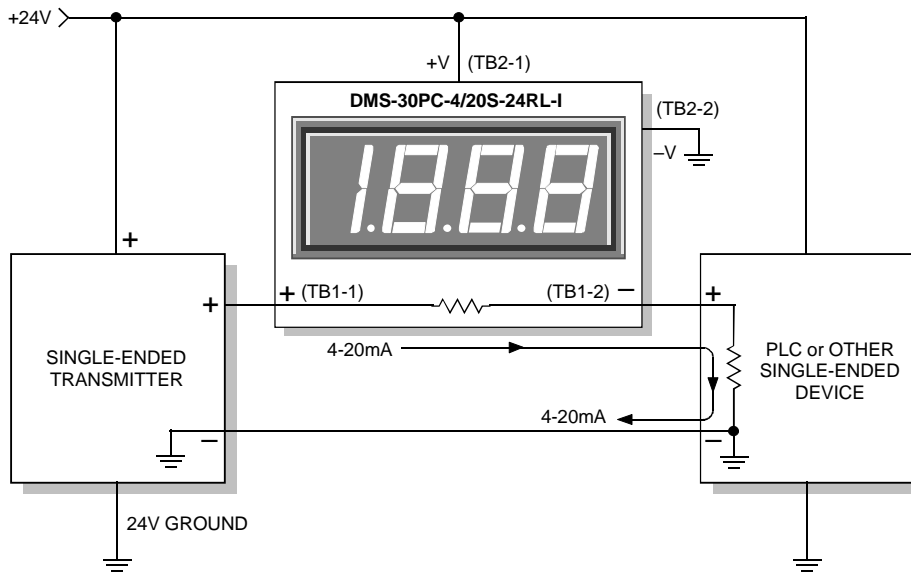

Figure 4. Typical Connections for Isolated-Supply Meters in Series with an Auxiliary Device

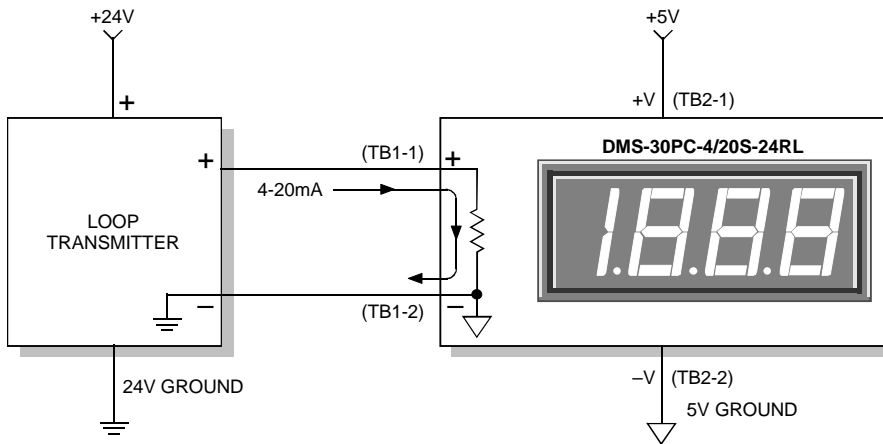
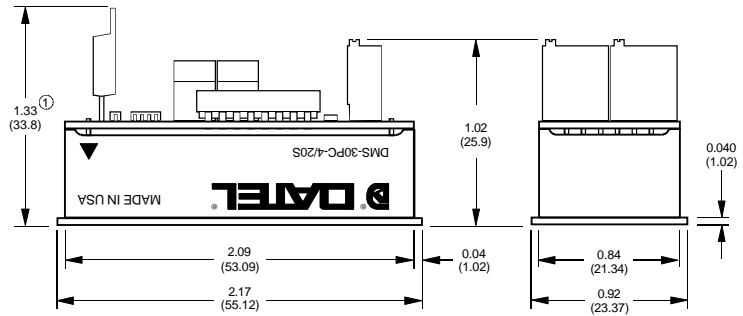

Figure 5. Typical Connections for +5V Powered Meters. Note that 5V Ground and 24V Ground are Tied Together Inside the Meter.

Mechanical Specifications

MECHANICAL DIMENSIONS: Inches (mm)
 TOLERANCES: 2 PL DEC ±0.02 (±0.51)
 3 PL DEC ±0.010 (±0.254)
 WIRE SIZE: 18 to 26 AWG
 (Solid or stranded)
 STRIPPING LENGTH: 0.20" (5.08mm)



① Depth dimension for the DMS-30PC-4/20S-24RL model only.

Back View

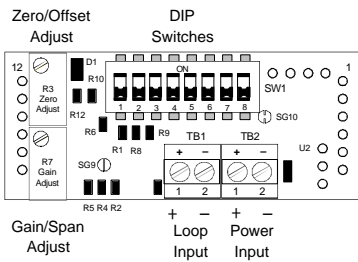

Front View



DP1 (SW5) DP2 (SW6) DP3 (SW7)

OPTIONAL BEZEL (DMS-BZL1 and DMS-BZL2)

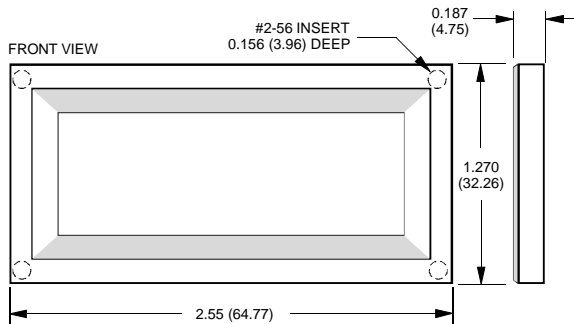

RECOMMENDED DRILL AND PANEL CUTOUT DIMENSIONS

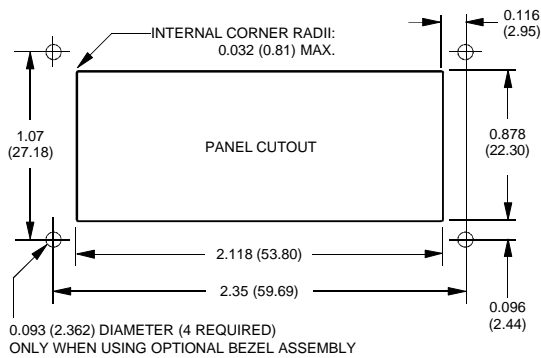

0.093 (2.362) DIAMETER (4 REQUIRED)
 ONLY WHEN USING OPTIONAL BEZEL ASSEMBLY

BEZEL INSTALLATION

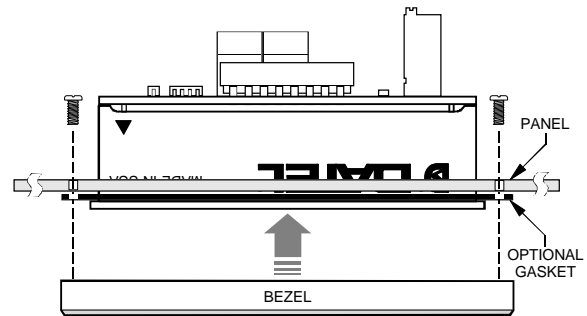

RETAINING CLIP INSTALLATION

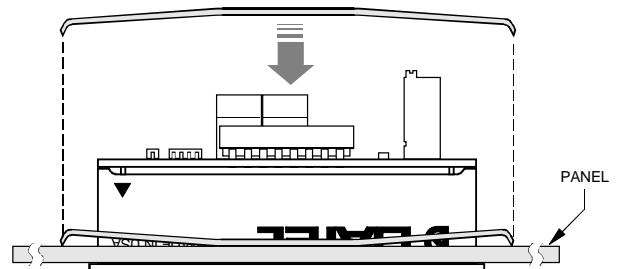

A panel-mount retaining clip is supplied with all models



ISO 9001 REGISTERED

DS-0337C 12/99

DATEL, Inc. 11 Cabot Boulevard, Mansfield, MA 02048-1151
 Tel: (508) 339-3000 (800) 233-2765 Fax: (508) 339-6356
 Internet: www.datel.com Email: sales@datel.com
 Data sheet fax back: (508) 261-2857

DATEL (UK) LTD. Tadley, England Tel: (01256)-880444
 DATEL S.A.R.L. Montigny Le Bretonneux, France Tel: 01-34-60-01-01
 DATEL GmbH München, Germany Tel: 89-544334-0
 DATEL KK Tokyo, Japan Tel: 3-3779-1031, Osaka Tel: 6-354-2025

DATEL makes no representation that the use of its products in the circuits described herein, or the use of other technical information contained herein, will not infringe upon existing or future patent rights. The descriptions contained herein do not imply the granting of license to make, use, or sell equipment constructed in accordance therewith. Specifications are subject to change without notice. The DATEL logo is a registered DATEL, Inc. trademark.