

Purchase On-Line

MasterCard VISA www.datel.com

D® **DATEL**®
INNOVATION and EXCELLENCE



DSD-40BCD Series

Miniature
4½ Digit, BCD Input
Slave LED Display

Features

- **Low cost! Complete!**
No external components required
- **Rugged, epoxy-encapsulated package**
- **Ideal for computer-based instruments**
- **Miniature size:**
2.17" x 0.92" x 0.56"
55mm x 23mm x 14mm
- **Built-in color filter and bezel**
- **Single +5V supply, TTL compatible**
- **Low-power model, 35mA (175mW)**
- **Large (0.52"/13.2mm), matched-intensity, LED display**
- **Choice of red or green LED's**
- **Minus sign and decimal points included**
- **PC-board or panel mountable**

DATEL's new DSD-40BCD digital slave display combines a full-size, 4½ digit, LED display with all the other necessary components (including a built-in, contrast-enhancing filter/bezel) to implement a pc-board mountable instrument display. The epoxy-encapsulated, 24-pin package, measuring only 2.17 x 0.92 x 0.56 inches, is perfectly sized to occupy the absolute minimum pc-board space. The one-piece LED display eliminates the need to purchase multiple, matched-intensity LED's — usually an expensive and limited-availability situation.

The DSD-40BCD's flexible design gives the user full control of all major display functions including display update rate, number of digits enabled, and decimal point selection. Its TTL-compatible inputs interface directly with most BCD output, integrating analog-to-digital converters — no additional glue logic is required! When used with sophisticated microcomputers, the brightness of any digit can be independently controlled by simply lowering the digit-drive input duty cycle.

The extremely rugged package allows all models to operate over the temperature range of 0 to +70°C (at 0 to 95% relative humidity). For power-sensitive designs, the low-power DSD-40BCD-RL model, with all digits turned on, draws only 35mA from its +5V supply. This ultra-low power consumption means that even battery-powered applications can now benefit from the superior readability offered by LED displays.

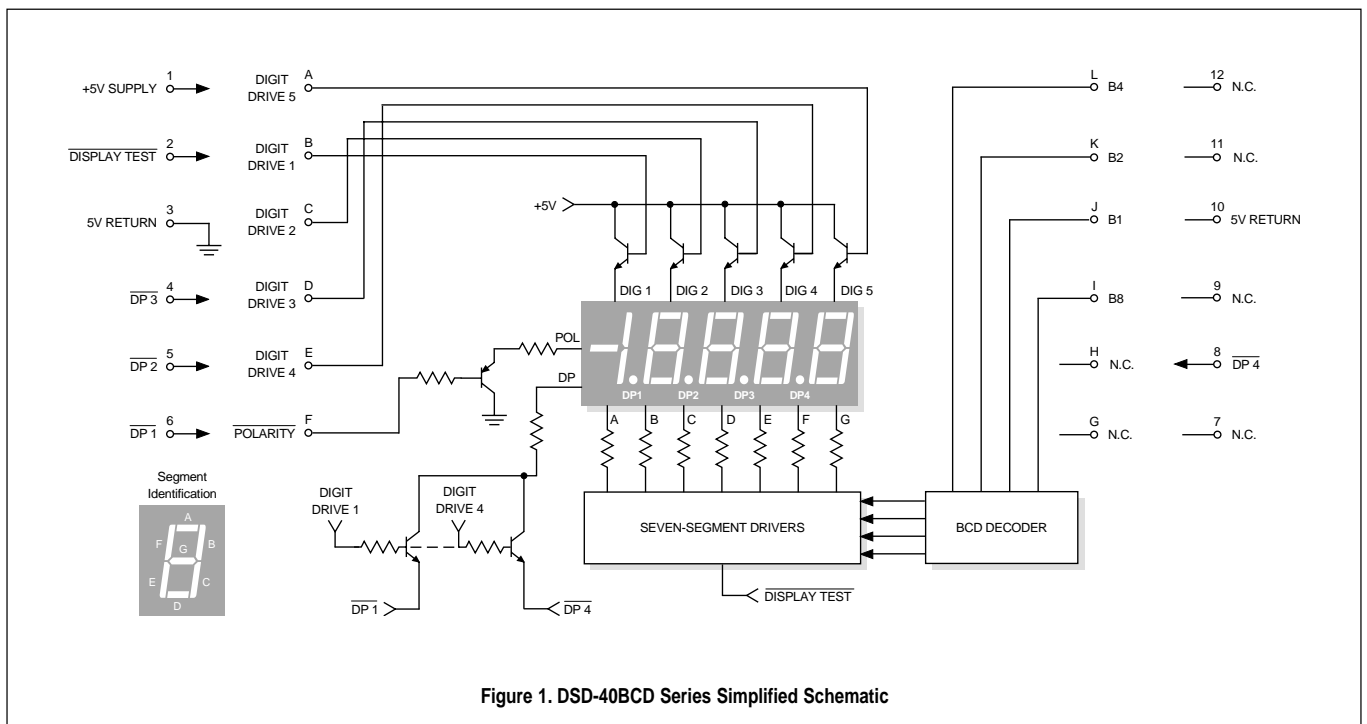

Figure 1. DSD-40BCD Series Simplified Schematic

Functional Specifications

T_A = +25°C and supply voltage = +5V, unless otherwise noted.

Control Inputs	Min.	Typ.	Max.	Units
BCD (pins I-L) and TEST (pin 2) Inputs:				
Low-Level Input Voltage (V _{IL})	--	--	+0.8	Volts
Low-Level Input Current (I _{IL})	--	--	0.4	mA
High-Level Input Voltage (V _{IH})	+2.4	--	--	Volts
High-Level Input Current (I _{IH})	--	--	0.05	mA
Polarity Input (pin F):				
Low-Level Input Voltage (V _{IL})	--	--	+0.8	Volts
Low-Level Input Current (I _{IL})	--	--	0.4	mA
High-Level Input Voltage (V _{IH})	+4.5	--	--	Volts
High-Level Input Current (I _{IH})	--	--	0.05	mA
Digit Drive Inputs (pins A-E):				
Low-Level Input Voltage (V _{IL})	--	--	+0.8	Volts
Low-Level Input Current (I _{IL})	--	--	0.4	mA
High-Level Input Voltage (V _{IH})	+4.5	--	--	Volts
High-Level Input Current (I _{IH})	--	--	2	mA
DP1-DP4 Inputs (pins 4-6, 8):				
Low-Level Input Voltage (V _{IL})	--	--	+0.8	Volts
Low-Level Input Current (I _{IL})	--	--	20	mA
High-Level Input Voltage (V _{IH})	+4.5	--	--	Volts
High-Level Input Current (I _{IH})	--	--	0.05	mA
Power Supply Requirements				
Supply Voltage	+4.75	+5.00	+5.25	Volts
Supply Current:				
DSD-40BCD-GS	--	+100	+130	mA
DSD-40BCD-RL	--	+35	+45	mA
DSD-40BCD-RS	--	+85	+110	mA
Display				
Display Type and Size	4½ Digit LED, 0.52"/13.2mm high			
LED Peak Wavelength (λ):				
DSD-40BCD-GS	--	565	--	nm
DSD-40BCD-RL	--	660	--	nm
DSD-40BCD-RS	--	635	--	nm
Physical/Environmental				
Operating Temperature	0	--	+70	°C
Storage Temperature	-40	--	+75	°C
Humidity (Non-condensing)	0	--	95	%
Case Material	Polycarbonate			
Weight	1 ounce (28 grams)			
BCD Inputs and Resultant Displays				

Order on-line at www.datel.com

Ordering Information

DSD-40BCD - R S

LED Color: GS = Standard Green
RL = Low-Power Red
RS = Standard Red

Accessories:

DMS-30-CP Panel cutout punch
DMS-BZL1 DSD-40 bezel assembly
DMS-BZL2 DSD-40 bezel assembly with sealing gasket

A panel-mount retaining clip is supplied with each model.

Technical Notes

1. DSD-40BCD Operation (Please Refer to the Timing and Pinout Diagrams for the Following Discussion): The DSD-40BCD display has five digits, labeled digit 1 (left-most digit or MSD) through digit 5 (right-most digit or LSD), which are turned on by bringing their respective DIGIT DRIVE inputs to a high logic level. The binary coded decimal data (BCD) on pins I-L is decoded into the corresponding seven-segment LED outputs necessary to display the numerals "0" through "9".

Since there are effectively five digits and only one set of BCD data inputs, the DSD-40BCD's digits have their segments tied ("multiplexed") together. The top segment, referred to as segment A, of digit 5 is connected to the A segment of the other three digits (digit 1 has no A segment). The remaining B, C, D, E, F and G segments are connected to each other in the same fashion.

As an example of how the multiplexing scheme works, assume that the BCD data inputs are 0001 (the BCD code for the decimal number 1) and also assume that the DIGIT DRIVE 3 input is high. Under these conditions, the B and C segments of digits 1-5 will all be enabled. However, only the digits whose DIGIT DRIVE inputs are high, in this case only digit 3, will display the numeral "1". All the other digits will be off. This example, while technically valid, will produce an extremely bright "1" for digit 3. This will be explained in greater detail in the section titled "Controlling the Display Brightness."

2. DSD-40BCD Timing Diagram (See Figure 2): The timing diagram depicts the required typical input conditions and timing relationships that allow the user to access all 5 digits. The recommended display scan rate is 100Hz. All 5 digits are scanned in 10ms, and each individual digit is "on" for 2ms (20% duty cycle). The 100Hz figure is not critical; it can go as low as 70Hz without any impact on display visibility.

The timing diagram shows the digits being scanned from left to right (DIGIT 1 to DIGIT 5), but this order is not mandatory. Any drive sequence can be used, as long as BCD data is presented at the correct corresponding DIGIT DRIVE interval. **An important point to keep in mind is that the DSD-40BCD has no internal data latches!** The DIGIT DRIVE and BCD data inputs must be continuously strobed to keep the display properly illuminated.

3. Decimal Point Inputs (DP1-DP4, Pins 4-6, 8): The four, active-low, decimal point segments are multiplexed in a similar, though not identical, manner as the rest of the digit segments. The four decimal points are controlled by their respective DIGIT DRIVE inputs. A selected decimal point may be permanently connected to ground. It will only be illuminated when its respective DIGIT DRIVE input is high. For example, if pin 6 (DP1) is hard-wired to pin 3 (5V RETURN), DP1 will only be on during the time interval that DIGIT DRIVE 1 is high.

As the specifications table clearly states, DP1-DP4 each require 20mA of sink current in order to achieve good illumination levels. Unused decimal points may be left open. The specified minimum V_{IH} applies only if logic-level devices are used to select the decimal points.

4. POLARITY (Pin F): The function of this active-low pin is to turn on the minus sign if negative readings are desired. The polarity input, like the decimal points, can also be permanently connected to ground. However, POLARITY is logic-level compatible and does not require

the high sink currents that $\overline{DP1}$ - $\overline{DP4}$ do. If negative readings are never displayed, the POLARITY input may be left open.

- 5. Controlling Display Brightness:** The LED current-setting components inside the DSD-40BCD are selected to produce good display brightness — while keeping power dissipation at reasonable levels — with a 20% duty cycle. Since no data latches are utilized in the DSD-40BCD design, the user can exercise full control over how many digits are enabled, and their relative brightness, by manipulating the duty cycle of the DIGIT DRIVE input.

To turn off one digit, for a four digit application, simply leave the respective DIGIT DRIVE input (DIGIT DRIVE 5 in this example) open or low. If the timing relationships remain unchanged (i.e., 20% duty cycle), the display brightness will remain the same as when all five digits are used. However, if the duty cycle is changed to 25% (because only four digits are used), the increase in display intensity will be noticeable. In most applications, this increase in intensity will not be significant enough to justify any timing changes.

- 6. Highlighting Selected Digits:** In many instrument designs, it is sometimes desirable to highlight or "flash" one particular digit to draw the user's attention to that digit. Once again, duty cycle control of the digit drive inputs makes this a relatively simple task. The easiest way is to flash the digit on and off, at a 0.5 to 1Hz rate, with the DIGIT DRIVE input. Keeping the duty cycle fixed at 20% for 5-digit applications, and 25% for 4-digits, will keep the intensity of the non-flashed digits uniform.

- 7. Power Supply Decoupling:** The DSD-40BCD is not sensitive to logic noise or spikes, on either the 5V supply or the data inputs, because it does not use any edge-triggered logic. However, it does generate a fair amount of switching transients due to the display's multiplexed architecture. A tantalum electrolytic capacitor, in the range of 15 to 22 μ F, in parallel with a 0.1 μ F ceramic capacitor will reduce the LED switching transients. These two capacitors should be located as close as possible to pins 1 and 3.

- 8. Interfacing BCD-Output A/D Converters:** The DSD-40BCD accepts the BCD data from DATEL's DMS-40PC-X-RS-BCD Series, 4½ Digit Panel Meters. DMS-40PC meters are exactly the same size as the DSD-40BCD display making it ideal for use in remote-display applications.

The DSD-40BCD will also interface directly with the ICL7135, 4½ digit, integrating A/D converter's BCD and DIGIT DRIVE outputs. The only difference is that the ICL7135 has its five DIGIT DRIVE outputs labeled in a right-to-left order, i.e., the 7135's MSD is labeled digit 5 and its LSD is labeled digit 1. This is opposite to the DSD-40BCD labeling its MSD digit 1 and its LSD digit 5. Please refer to the 7135's data sheet for more information.

- 9. DISPLAY TEST (Pin 2):** The DSD-40BCD's display can have all its segments enabled by bringing DISPLAY TEST low. The display will show "-18888" (excluding the decimal points) as long as the digit drive inputs are continuously strobed.
- 10. Soldering Methods:** DSD-40BCD Series displays easily withstand most common manual and wave soldering operations. However, we highly recommend that you evaluate the effects your particular soldering techniques may have on the display's polycarbonate case and overall performance. We also recommend the use of no-clean solders since their residue normally has no detrimental effects on low-speed digital devices.

11. Suggested Mating Connectors:

Board mounted:

Socket DATEL P/N 39-2359624

Panel mounted:

DATEL recommends the use of IDC (insulation displacement) connectors when panel mounting the DSD-40BCD. SAMTEC's HCS series of IDC cable strips can be ordered in a variety of lengths and connector terminations. Please contact SAMTEC, Inc. at:

USA (Indiana)	812-944-6733	Fax: 812-948-5047
Europe (Scotland)	01236-739292	Fax: 01236-727113
Asia (Singapore)	65-745-5955	Fax: 65-841-1502

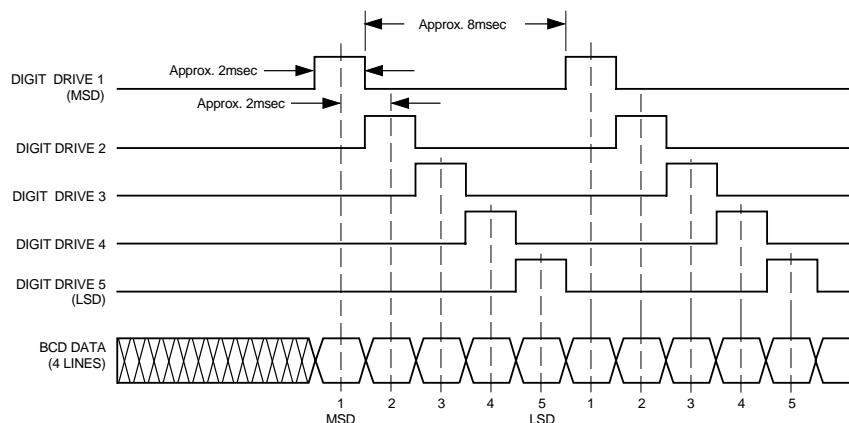

Notes:

1. Maximum allowable digit-to-digit overlap is 5 sec.
2. Maximum allowable digit-to-BCD data skew is also 5 sec.

Figure 2. BCD Data Timing Diagram

Mechanical Specifications

MECHANICAL DIMENSIONS: Inches (mm)
 TOLERANCES: 2 PL DEC ±0.02 (±0.51)
 3 PL DEC ±0.010 (±0.254)

LEAD DIMENSIONS: 0.025 (0.635) x 0.025 (0.635) NOMINAL
 RECOMMENDED PC BOARD FINISHED HOLE DIAMETER:
 0.042 ±0.003 (1.067 ±0.076)

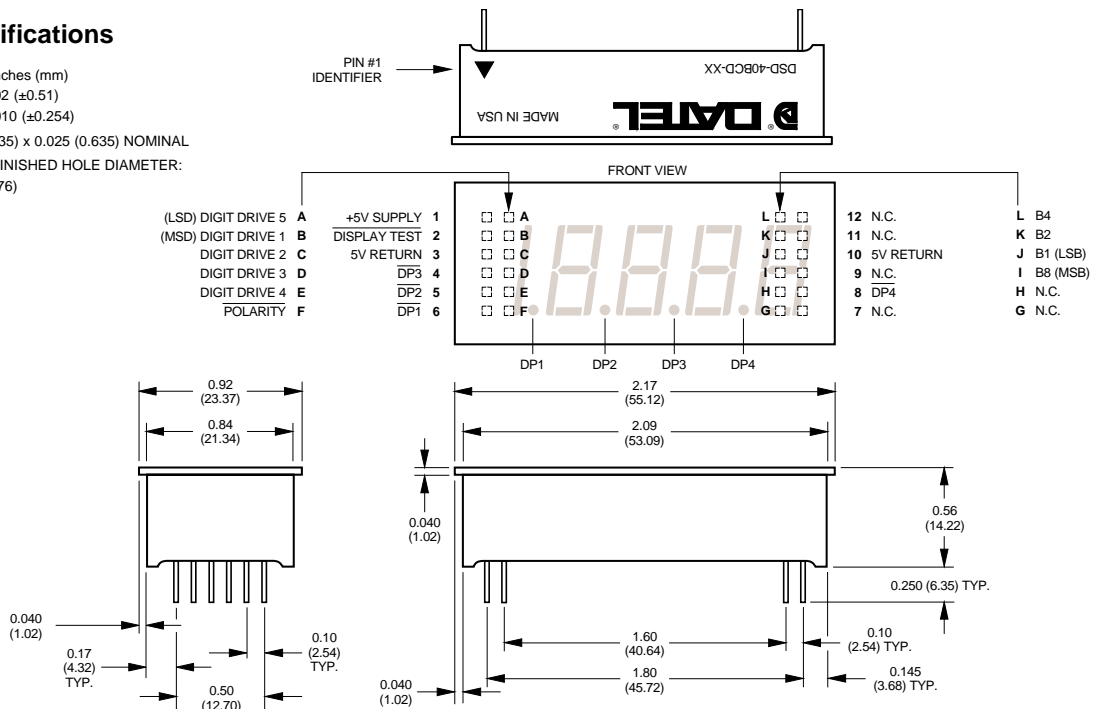

OPTIONAL BEZEL (DMS-BZL1 and DMS-BZL2)

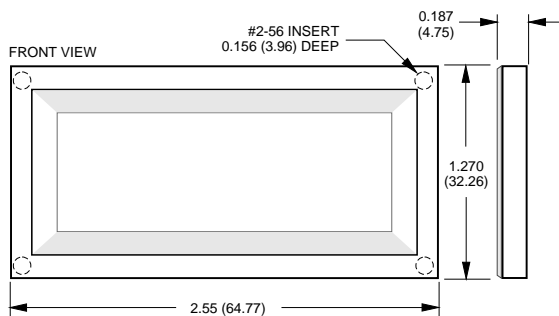

RECOMMENDED DRILL AND PANEL CUTOUT DIMENSIONS

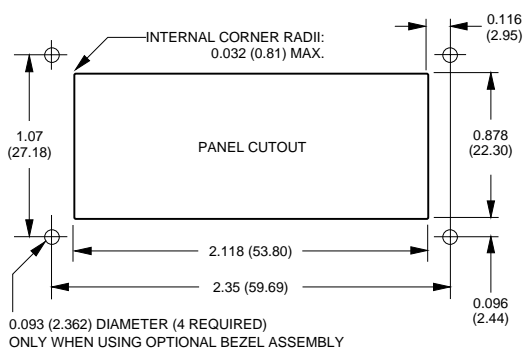

BEZEL INSTALLATION

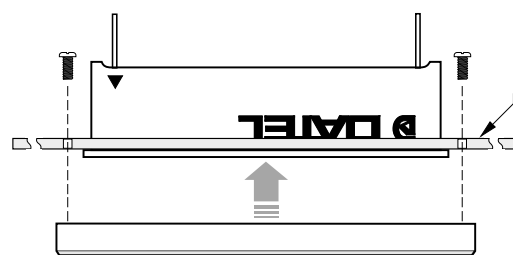

RETAINING CLIP INSTALLATION

