

FEATURES

- 16-bit resolution
- 1MHz minimum sampling rate
- No missing codes over full military temperature range
- Very low power, 1.25 Watts
- Small, 32-pin, side-brazed, ceramic TDIP
- Edge-triggered
- Excellent performance
- Ideal for both time and frequency-domain applications
- Low cost



GENERAL DESCRIPTION

The low-cost ADS-937 is a 16-bit, 1MHz sampling A/D converter. This device accurately samples full-scale input signals up to Nyquist frequencies with no missing codes. This feature, combined with excellent signal-to-noise ratio (SNR) and total harmonic distortion (THD), makes the ADS-937 the ideal choice for both time-domain (CCD/medical imaging, scanners, process control) and frequency-domain (radar, telecommunications, spectrum analysis) applications.

Packaged in a 32-pin, side-brazed, metal-sealed, ceramic TDIP, the functionally complete ADS-937 contains a fast-settling sample-hold amplifier, a subranging (two-pass) A/D converter, an internal reference, timing/control logic, and error-correction circuitry. Digital input and output levels are TTL. ADS-937 only requires the rising edge of the start convert pulse to operate.

Requiring ±15V and ±5V supplies, the ADS-937 typically dissipates 1.25 Watts. The device is offered with both bipolar (±5V) and unipolar (0 to -10V) analog input ranges. Models are available for use in either commercial (0 to +70°C) or

INPUT/OUTPUT CONNECTIONS

PIN	FUNCTION	PIN	FUNCTION
1	ANALOG INPUT	32	BIT 1 (MSB)
2	ANALOG GROUND	31	BIT 2
3	UNIPOLAR	30	BIT 3
4	OFFSET ADJUST	29	BIT 4
5	+5V REFERENCE OUT	28	BIT 5
6	GAIN ADJUST	27	BIT 6
7	COMPENSATION	26	BIT 7
8	-15V SUPPLY	25	BIT 8
9	+15V SUPPLY	24	BIT 9
10	+5V ANALOG SUPPLY	23	BIT 10
11	-5V ANALOG SUPPLY	22	BIT 11
12	ANALOG GROUND	21	BIT 12
13	DIGITAL GROUND	20	BIT 13
14	+5V DIGITAL SUPPLY	19	BIT 14
15	EOC	18	BIT 15
16	START CONVERT	17	BIT 16 (LSB)

military (-55 to +125°C) operating temperature ranges. A proprietary, auto-calibrating, error-correcting circuit enables the device to achieve specified performance over the full military temperature range.

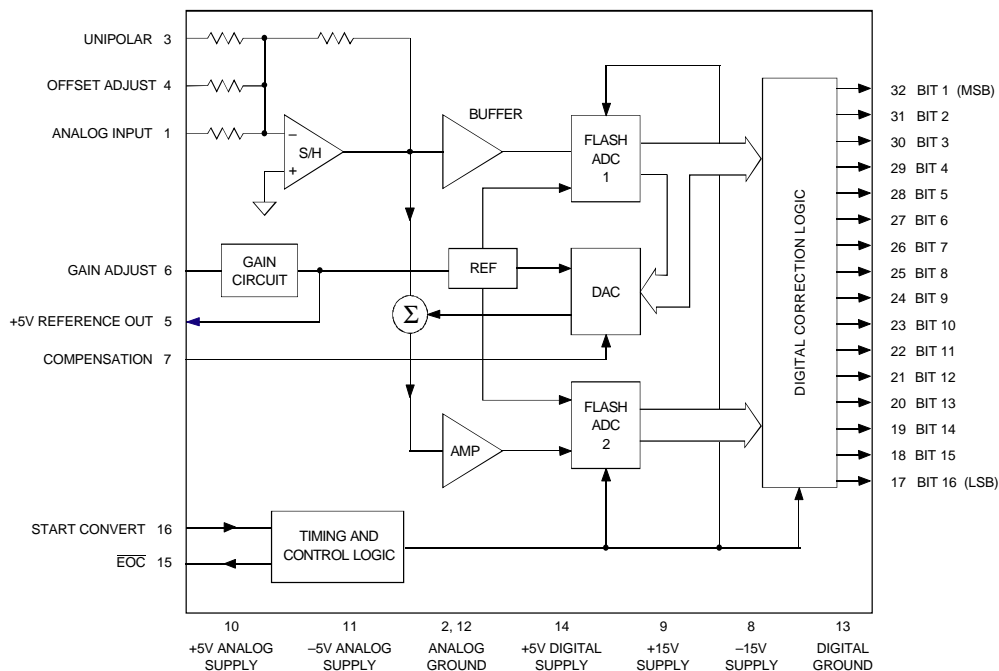

Figure 1. ADS-937 Functional Block Diagram

ABSOLUTE MAXIMUM RATINGS

PARAMETERS	LIMITS	UNITS
+15V Supply (Pin 9)	0 to +16	Volts
-15V Supply (Pin 8)	0 to -16	Volts
+5V Supply (Pins 10, 14)	0 to +6	Volts
-5V Supply (Pin 11)	0 to -6	Volts
Digital Input (Pin 16)	-0.3 to +V _{DD} +0.3	Volts
Analog Input (Pin 1)	±15	Volts
Lead Temperature (10 seconds)	+300	°C

PHYSICAL/ENVIRONMENTAL

PARAMETERS	MIN.	TYP.	MAX.	UNITS
Operating Temp. Range, Case	0	—	+70	°C
	-55	—	+125	°C
Thermal Impedance	—	5	—	°C/Watt
	—	22	—	°C/Watt
Storage Temperature Range	-65	—	+150	°C
Package Type	32-pin, side-brazed, metal-sealed, ceramic TDIP			
Weight	0.56 ounces (16 grams)			

FUNCTIONAL SPECIFICATIONS

(T_A = +25°C, ±V_{CC} = ±15V, ±V_{DD} = ±5V, 1MHz sampling rate, and a minimum 1 minute warm-up ① unless otherwise specified.)

ANALOG INPUTS	+25°C			0 to +70°C			-55 to +125°C			UNITS	
	MIN.	TYP.	MAX.	MIN.	TYP.	MAX.	MIN.	TYP.	MAX.		
Input Voltage Ranges ②	Bipolar	—	±5	—	—	±5	—	—	±5	—	Volts
	Unipolar	—	0 to -10	—	—	0 to -10	—	—	0 to -10	—	Volts
	Input Resistance	—	1	—	—	1	—	—	1	—	kΩ
Input Capacitance	—	7	15	—	7	15	—	7	15	—	pF
DIGITAL INPUTS											
Logic Levels	Logic "1"	+2.0	—	—	+2.0	—	—	+2.0	—	—	Volts
	Logic "0"	—	—	+0.8	—	—	+0.8	—	—	+0.8	Volts
	Logic Loading "1"	—	—	+20	—	—	+20	—	—	+20	µA
	Logic Loading "0"	—	—	-20	—	—	-20	—	—	-20	µA
	Start Convert Positive Pulse Width ③	20	500	—	20	500	—	20	500	—	ns
STATIC PERFORMANCE											
Resolution	—	16	—	—	16	—	—	16	—	—	Bits
Integral Nonlinearity	—	±0.75	—	—	±1.5	—	—	±2	—	—	LSB
Differential Nonlinearity (f _{in} = 10kHz)	-0.95	±0.5	+1	-0.95	±0.5	+1	-0.95	±0.5	+1.5	—	LSB
Full Scale Absolute Accuracy	—	±0.1	±0.25	—	±0.2	±0.4	—	±0.25	±0.5	—	%FSR
Bipolar Zero Error (Tech Note 2)	—	±0.1	±0.15	—	±0.1	±0.25	—	±0.15	±0.5	—	%FSR
Bipolar Offset Error (Tech Note 2)	—	±0.1	±0.2	—	±0.15	±0.3	—	±0.2	±0.5	—	%FSR
Gain Error (Tech Note 2)	—	±0.1	±0.3	—	±0.25	±0.5	—	±0.4	±0.7	—	%
Unipolar Offset Error (Tech Note 2)	—	±0.1	±0.15	—	±0.1	±0.25	—	±0.15	±0.5	—	%FSR
No Missing Codes (f _{in} = 10kHz)	16	—	—	16	—	—	16	—	—	—	Bits
DYNAMIC PERFORMANCE											
Peak Harmonics (-0.5dB)	dc to 100kHz	—	-90	-84	—	-90	-84	—	-88	-83	dB
	100kHz to 500kHz	—	-88	-81	—	-88	-81	—	-87	-80	dB
Total Harmonic Distortion (-0.5dB)	dc to 100kHz	—	-87	-82	—	-87	-82	—	-86	-81	dB
	100kHz to 500kHz	—	-86	-81	—	-86	-81	—	-85	-80	dB
Signal-to-Noise Ratio (w/o distortion, -0.5dB)	dc to 100kHz	85	88	—	85	88	—	84	87	—	dB
	100kHz to 500kHz	84	87	—	84	87	—	83	87	—	dB
Signal-to-Noise Ratio ④ (& distortion, -0.5dB)	dc to 100kHz	81	85	—	81	85	—	80	84	—	dB
	100kHz to 500kHz	80	84	—	80	84	—	78	83	—	dB
Noise	—	110	—	—	110	—	—	110	—	—	µVrms
Two-Tone Intermodulation Distortion (f _{in} = 100kHz, 240kHz, f _s = 1MHz, -0.5dB)	—	-85	—	—	-85	—	—	-85	—	—	dB
Input Bandwidth (-3dB)	Small Signal (-20dB input)	—	4.5	—	—	4.5	—	—	4.5	—	MHz
	Large Signal (-0.5dB input)	—	4	—	—	4	—	—	4	—	MHz
Feedthrough Rejection (f _{in} = 500kHz)	—	84	—	—	84	—	—	84	—	—	dB
Slew Rate	—	±33	—	—	±33	—	—	±33	—	—	V/µs
Aperture Delay Time	—	+20	—	—	+20	—	—	+20	—	—	ns
Aperture Uncertainty	—	5	—	—	5	—	—	5	—	—	ps rms
S/H Acquisition Time (to ±0.003%FSR, 10V step)	—	260	300	—	260	300	—	260	300	—	ns
Overvoltage Recovery Time ⑤	—	500	1000	—	500	1000	—	500	1000	—	ns
A/D Conversion Rate	1	—	—	1	—	—	1	—	—	—	MHz

ANALOG OUTPUT	+25°C			0 to +70°C			-55 to +125°C			UNITS
	MIN.	TYP.	MAX.	MIN.	TYP.	MAX.	MIN.	TYP.	MAX.	
Internal Reference										
Voltage	+4.95	+5.0	+5.05	+4.95	+5.0	+5.05	+4.95	+5.0	+5.05	Volts
Drift	—	±30	—	—	±30	—	—	±30	—	ppm/°C
External Current	—	1	—	—	1	—	—	1	—	mA
DIGITAL OUTPUTS										
Logic Levels										
Logic "1"	+2.4	—	—	+2.4	—	—	+2.4	—	—	Volts
Logic "0"	—	—	+0.4	—	—	+0.4	—	—	+0.4	Volts
Logic Loading "1"	—	—	-4	—	—	-4	—	—	-4	mA
Logic Loading "0"	—	—	+4	—	—	+4	—	—	+4	mA
Output Coding	Complementary Binary / Complementary Offset Binary									
POWER REQUIREMENTS										
Power Supply Ranges										
+15V Supply	+14.5	+15.0	+15.5	+14.5	+15.0	+15.5	+14.5	+15.0	+15.5	Volts
-15V Supply	-14.5	-15.0	-15.5	-14.5	-15.0	-15.5	-14.5	-15.0	-15.5	Volts
+5V Supply	+4.75	+5.0	+5.25	+4.75	+5.0	+5.25	+4.75	+5.0	+5.25	Volts
-5V Supply	-4.75	-5.0	-5.25	-4.75	-5.0	-5.25	-4.75	-5.0	-5.25	Volts
Power Supply Currents										
+15V Supply	—	+7	+9	—	+7	+9	—	+7	+9	mA
-15V Supply	—	-8	-10	—	-8	-10	—	-8	-10	mA
+5V Supply	—	+133	+145	—	+133	+145	—	+133	+145	mA
-5V Supply	—	-72	-80	—	-72	-80	—	-72	-80	mA
Power Dissipation	—	1.25	1.35	—	1.25	1.35	—	1.25	1.35	Watts
Power Supply Rejection	—	—	±0.01	—	—	±0.01	—	—	±0.01	%FSR/%V
Footnotes:										
① All power supplies must be on before applying a start convert pulse. All supplies and the clock (START CONVERT) must be present during warm-up periods. The device must be continuously converting during this time.					④ Effective bits is equal to: $\frac{(\text{SNR} + \text{Distortion}) - 1.76 + \left[20 \log \frac{\text{Full Scale Amplitude}}{\text{Actual Input Amplitude}} \right]}{6.02}$					
② Contact DATEL for other input voltage ranges.					⑤ This is the time required before the A/D output data is valid once the analog input is back within the specified range.					
③ A 1MHz clock with a 500nsec positive pulse width (50% duty cycle) is used for all production testing. Any duty cycle may be used as long as a minimum positive pulse width of 20nsec is maintained. For applications requiring lower sampling rates, clock frequencies less than 1MHz may be used.										

TECHNICAL NOTES

1. Obtaining fully specified performance from the ADS-937 requires careful attention to pc-card layout and power supply decoupling. The device's analog and digital ground systems are not connected to each other internally. For optimal performance, tie all ground pins (2, 12 and 13) directly to a large **analog** ground plane beneath the package.

Bypass all power supplies and the +5V REFERENCE OUTPUT (pin 5) to ground with 4.7µF tantalum capacitors in parallel with 0.1µF ceramic capacitors. Locate the bypass capacitors as close to the unit as possible. Tie a 47µF capacitor between COMPENSATION (pin 7) and ground (See figure 2.).

2. The ADS-937 achieves its specified accuracies without the need for external calibration. If required, the device's small initial offset and gain errors can be reduced to zero using the adjustment circuitry shown in Figure 2. When using this circuitry, or any similar offset and gain calibration hardware, make adjustments following warm-up. To avoid interaction, always adjust offset before gain. Float pins 4 and 6 if not using offset and gain adjust circuits.

3. Applying a start convert pulse while a conversion is in progress (EOC = logic "1") will initiate a new and inaccurate conversion cycle. Data for the interrupted and subsequent conversions will be invalid.

THERMAL REQUIREMENTS

All DATEL sampling A/D converters are fully characterized and specified over operating temperature (case) ranges of 0 to +70°C and -55 to +125°C. All room-temperature (T_A = +25°C) production testing is performed without the use of heat sinks or forced-air cooling. Thermal impedance figures for each device are listed in their respective specification tables.

These devices do not normally require heat sinks, however, standard precautionary design and layout procedures should be used to ensure devices do not overheat. The ground and power planes beneath the package, as well as all pcb signal runs to and from the device, should be as heavy as possible to help conduct heat away from the package. Electrically-insulating, thermally-conductive "pads" may be installed underneath the package. Devices should be soldered to boards rather than "socketed", and of course, minimal air flow over the surface can greatly help reduce the package temperature.

CALIBRATION PROCEDURE

Connect the converter per Table 1 for the appropriate input voltage range. Any offset/gain calibration procedures should not be implemented until the device is fully warmed up. To avoid interaction, adjust offset before gain. The ranges of adjustment for the circuits in Figure 2 are guaranteed to compensate for the ADS-937's initial accuracy errors and may not be able to compensate for additional system errors.

A/D converters are calibrated by positioning their digital outputs exactly on the transition point between two adjacent digital output codes. This is accomplished by connecting LED's to the digital outputs and performing adjustments until certain LED's "flicker" equally between on and off. Other approaches employ digital comparators or microcontrollers to detect when the outputs change from one code to the next.

For the ADS-937, offset adjusting is normally accomplished when the analog input is 0 minus 1/2LSB (-76.3µV). See Table 2 for the proper bipolar and unipolar output coding.

Gain adjusting is accomplished when the analog input is at nominal full scale minus 1 1/2LSB's (-9.999771V for unipolar and -4.999771V for bipolar).

Zero/Offset Adjust Procedure

1. Apply a train of pulses to the START CONVERT input (pin 16) so that the converter is continuously converting.
2. For unipolar or bipolar zero/offset adjust, apply -76.3µV to the ANALOG INPUT (pin 1).

3. For a bipolar input - Adjust the offset potentiometer until the output code flickers equally between 1000 0000 0000 0000 and 0111 1111 1111 1111.

For a unipolar input - Adjust the offset potentiometer until all output bits are 0's and the LSB flickers between 0 and 1.

Gain Adjust Procedure

1. Apply -4.999771V to the ANALOG INPUT (pin 1) for bipolar gain adjust or apply -9.999771V to pin 1 for unipolar gain adjust.

2. For a unipolar input - Adjust the gain potentiometer until all output bits are 1's and the LSB flickers between 1 and 0.

For a bipolar input - Adjust the gain potentiometer until all output bits are 1's and the LSB flickers between 1 and 0.

3. To confirm proper operation of the device, vary the applied input voltage to obtain the output coding listed in Table 2.

Table 1. Input Connections

INPUT VOLTAGE RANGE	INPUT PIN	TIE TOGETHER
±5V 0 to -10V	Pin 1 Pin 1	Pins 2 and 3 Pins 3 and 5

Table 2. Output Coding

UNIPOLAR SCALE	INPUT VOLTAGE 0 to -10V	COMPLEMENTARY BINARY		COMPLEMENTARY OFFSET BINARY		INPUT RANGE ±5V	BIPOLAR SCALE
		OUTPUT CODING					
		MSB	LSB	MSB	LSB		
-FS +1 LSB	-9.999847	1111 1111 1111 1111	0000 0000 0000 0000	0000 0000 0000 0000	0001 1111 1111 1111	+4.999847	+FS -1 LSB
-7/8 FS	-8.750000	1110 0000 0000 0000	0001 1111 1111 1111	0001 1111 1111 1111	0011 1111 1111 1111	+3.750000	+3/4 FS
-3/4 FS	-7.500000	1100 0000 0000 0000	0011 1111 1111 1111	0011 1111 1111 1111	0111 1111 1111 1111	+2.500000	+1/2 FS
-1/2 FS	-5.000000	1000 0000 0000 0000	0111 1111 1111 1111	0111 1111 1111 1111	0111 1111 1111 1111	+0.000000	0
-1/4 FS	-2.500000	0100 0000 0000 0000	1011 1111 1111 1111	1011 1111 1111 1111	1011 1111 1111 1111	-2.500000	-1/2 FS
-1/8 FS	-1.250000	0010 0000 0000 0000	1101 1111 1111 1111	1101 1111 1111 1111	1101 1111 1111 1111	-3.750000	-3/4 FS
-1 LSB	-0.000153	0000 0000 0000 0001	1111 1111 1111 1110	1111 1111 1111 1110	1111 1111 1111 1110	-4.999847	-FS +1 LSB
0	0.000000	0000 0000 0000 0000	1111 1111 1111 1111	1111 1111 1111 1111	1111 1111 1111 1111	-5.000000	-FS

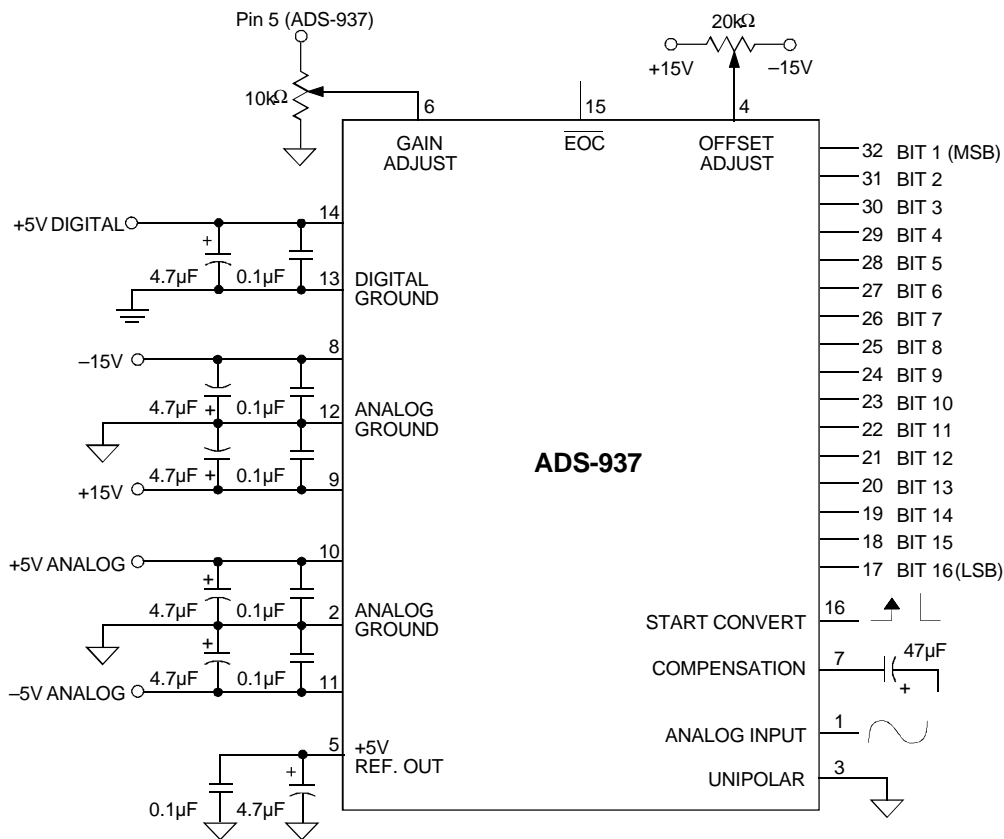
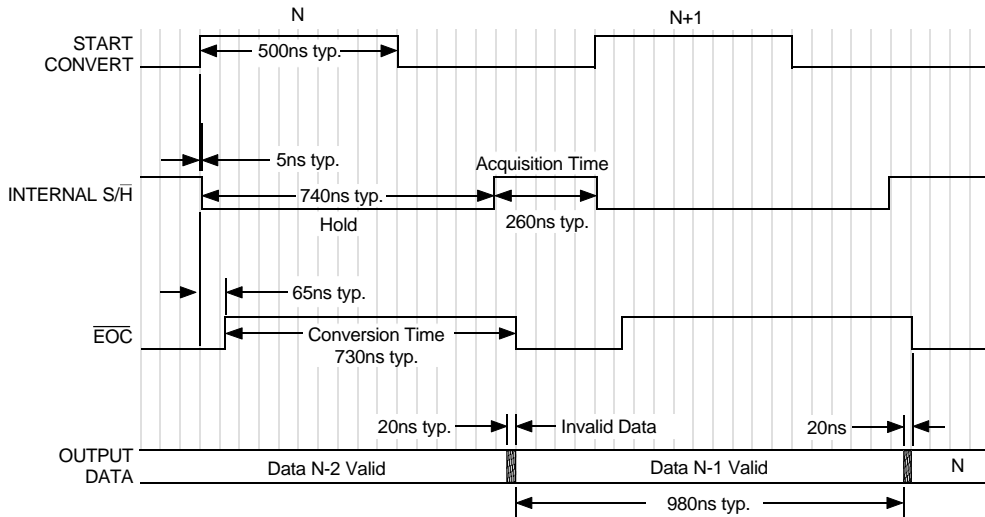

Figure 2. Typical ADS-937 Connection Diagram



Note: Scale is approximately 50ns per division. Sampling Rate = 1MHz.

Figure 3. ADS-937 Timing Diagram

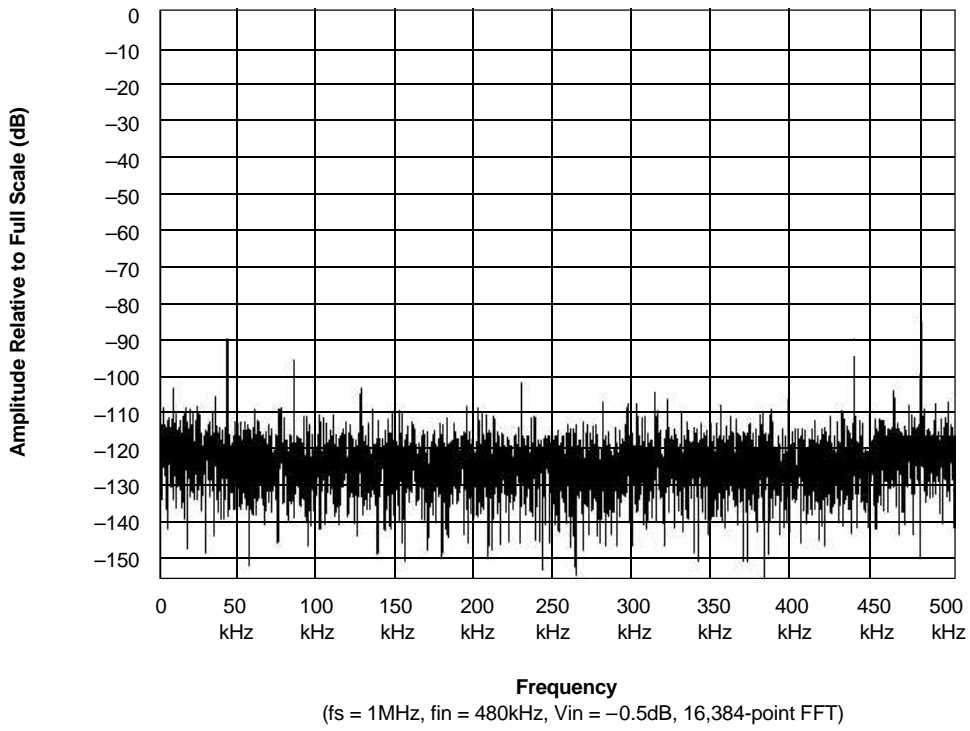

Figure 4. FFT Analysis of ADS-937

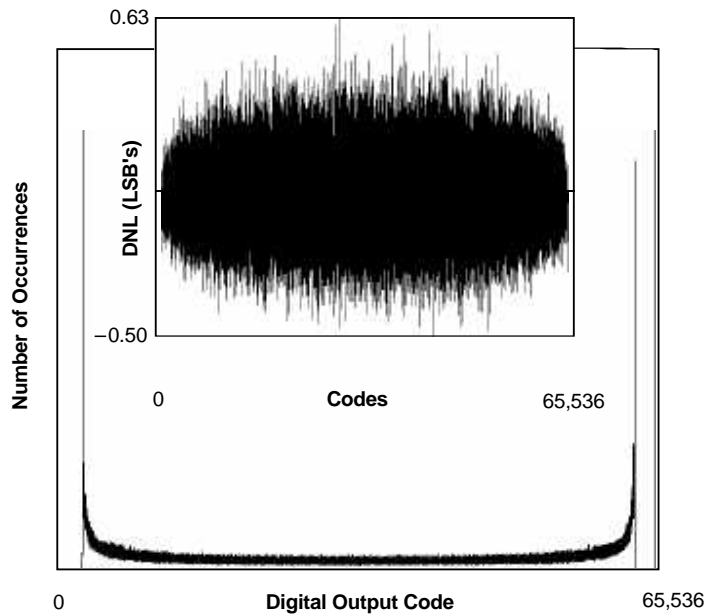

Figure 5. ADS-937 Histogram and Differential Nonlinearity

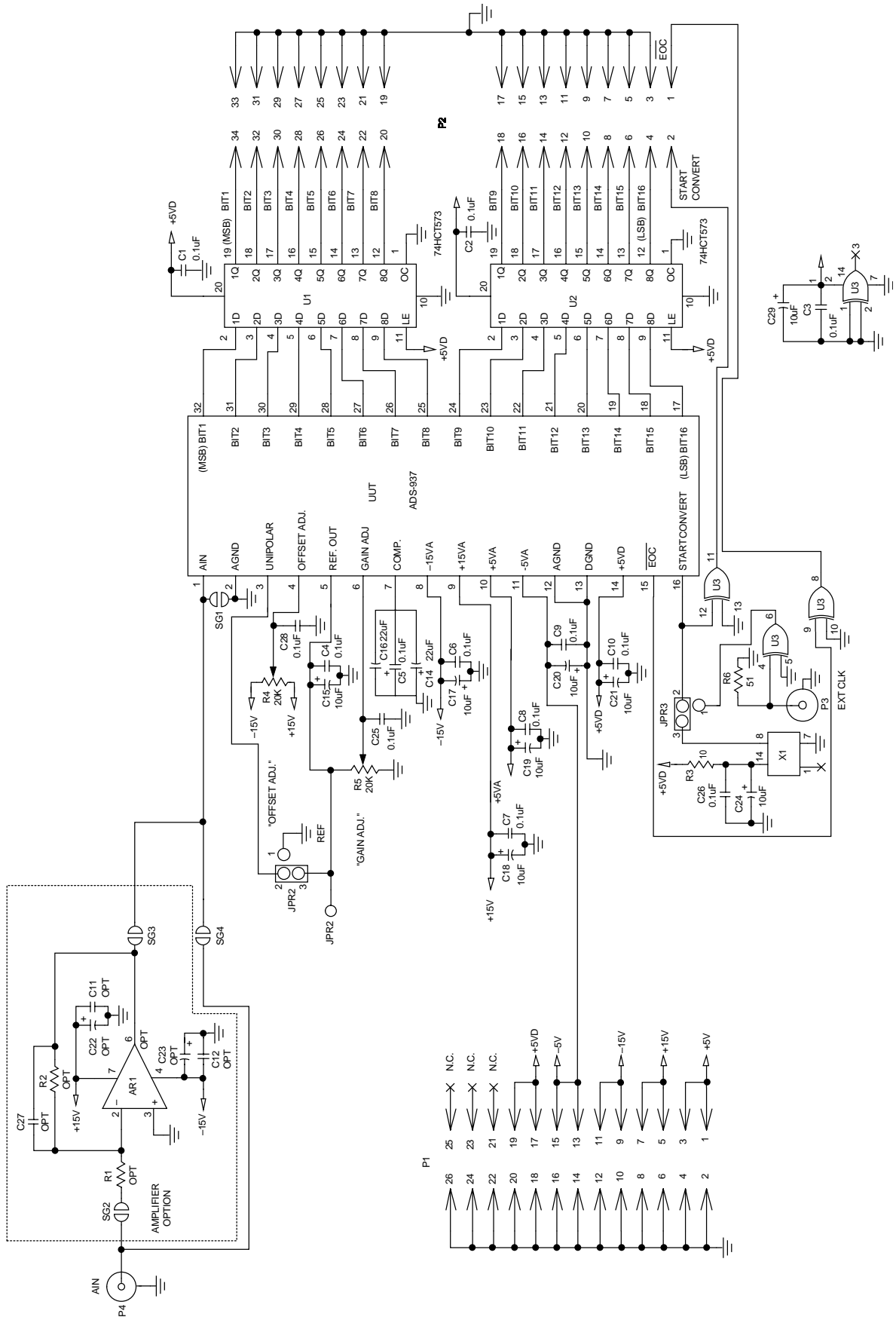
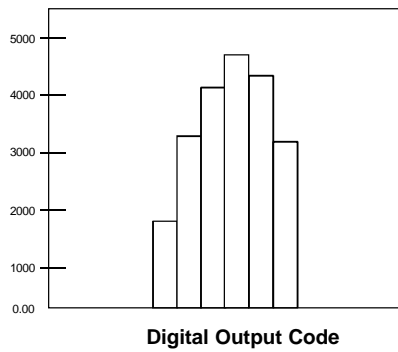

Figure 6. ADS-937 Evaluation Board



This histogram represents the typical peak-to-peak noise (including quantization noise) associated with the ADS-937.

Figure 7. ADS-937 Grounded Input Histogram

MECHANICAL DIMENSIONS INCHES (mm)

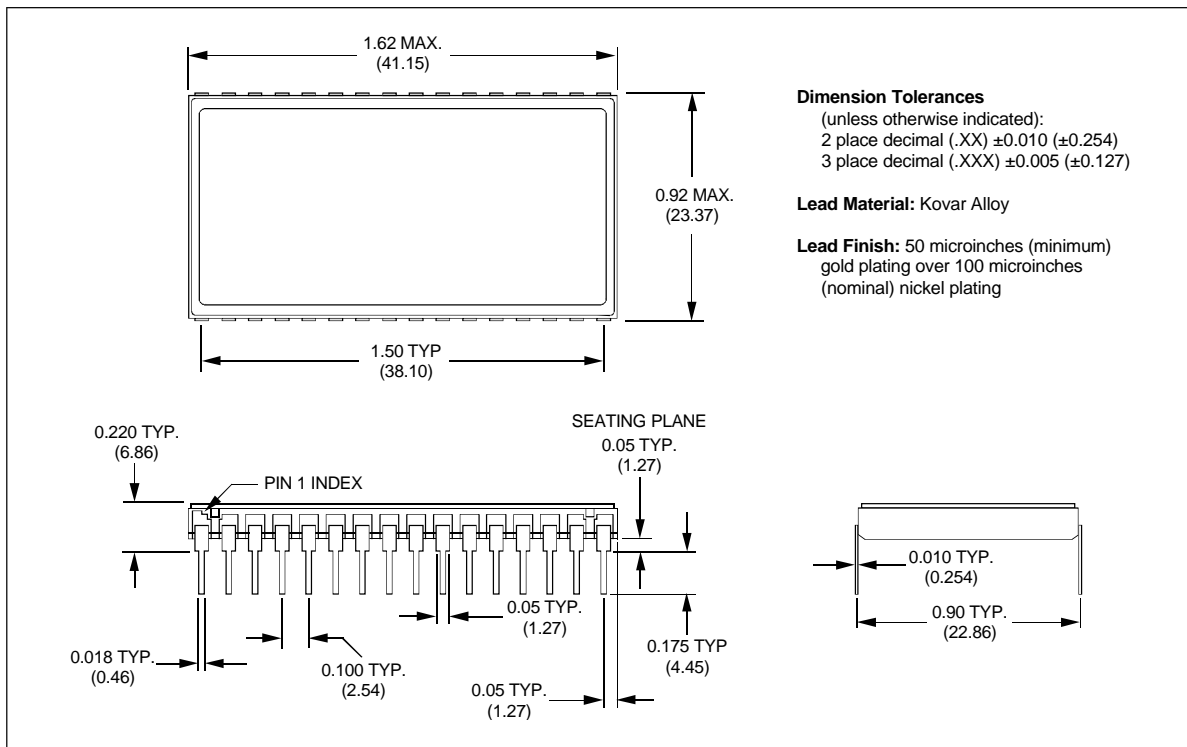

ORDERING INFORMATION

MODEL NUMBER	OPERATING TEMP. RANGE	32-PIN PACKAGE	ACCESSORIES
ADS-937MC	0 to +70°C	TDIP	ADS-B937 Evaluation Board (without ADS-937)
ADS-937MM	-55 to +125°C	TDIP	
ADS-937/883	-55 to +125°C	TDIP	

Receptacles for pc board mounting can be ordered through AMP, Inc., Part # 3-331272-8 (Component Lead Socket), 32 required. For availability of MIL-STD-883 product, contact DATEL.