

Dual Output BWP Models

DIP-Packaged, Standard-Pinout 3 Watt, DC/DC Converters

Features

- Low cost! High quality!
- Highly reliable, 100% SMT construction
- Standard DIP package and pinout
- No external components required
- ± 5 , ± 12 or ± 15 Volt outputs
- Choice of 3 wide input ranges:
 - 4.5-9 Volts
 - 9-18 Volts
 - 18-72 Volts
- Guaranteed efficiencies to 75%
- Fully isolated, 500Vdc guaranteed
- Internal input/output filtering
- Output current limiting
- -40 to $+75^\circ\text{C}$ operation with no derating
- UL1950/C22.2 No. 950/IEC950 certified
- Modifications and customs for OEM's

The proven cost-effectiveness, quality and long-term reliability that has come to define DATEL's standard, 3W, dual-output, DIP-packaged DC/DC converters (see BST 3W Models) is now available in the "other standard pinout" (see next page) made popular by off-shore suppliers. These newly designed BWP Models exploit totally automated SMT assembly techniques and do not contain any trimpots, "wet" aluminum electrolytic capacitors, or manually soldered "flying" leads. Their made-in-the-USA quality and affordable pricing are rapidly making them the converters of choice in many existing applications.

BWP DC/DC converters bring true component-like convenience to designers of modern distributed power systems. Exploiting an efficient, high-frequency (170-200kHz), flyback topology and high-density SMT assembly techniques, BWP DC/DC's have enough space to include input (π type) and output filters within their package. They are fully isolated (500Vdc guaranteed) and do not require any external components to meet published specifications. They operate, without derating, over the full -40 to $+75^\circ\text{C}$ temperature range.

Output voltages are either ± 5 , ± 12 or ± 15 Volts. Input voltage ranges are either 4.5-9V ("D5" models), 9-18V ("D12" models) or an ultra-wide 18-72V ("D48" models). Output transient response time is a quick 200 μsec , and output ripple and noise are typically 75mVp-p. All models are certified to UL1950, CSA 22.2 No. 950 and IEC950. Full EMI/EMC characterizations are currently in progress.

DATEL's BWP Model 3W DC/DC's are ideal replacements for other more costly, less reliable power converters as well as excellent choices for new design-ins in systems demanding small size, low cost and high reliability.

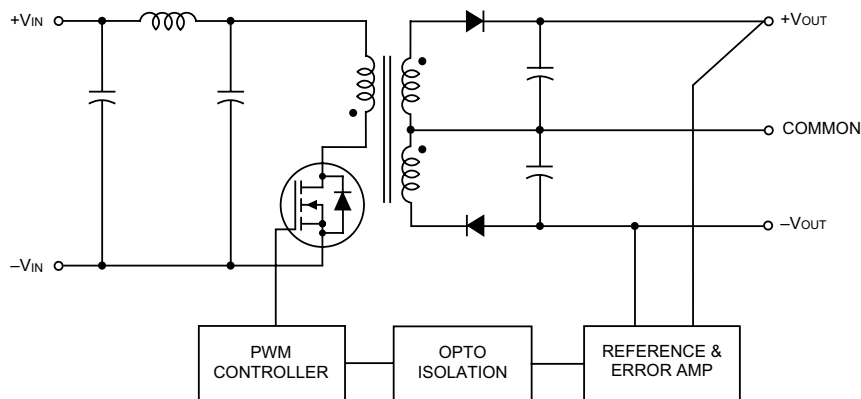

Figure 1. Simplified Schematic

Performance Specifications and Ordering Guide ^①

Model	Output						Input			Efficiency		Package (Case, Pinout)
	V _{OUT} (Volts)	I _{OUT} (mA, Max.)	R/N (mVp-p) ^②		Regulation (Max.)		V _{IN} Nom. (Volts)	Range (Volts)	I _{IN} ^④ (mA)	Min.	Typ.	
			Typ.	Max.	Line	Load ^③						
BWP-5/250-D12	±5	±250	75	120	±0.5%	±0.5%	12	9-18	25/267	75%	78%	C1A, P20
BWP-5/250-D48	±5	±250	75	120	±0.5%	±0.5%	48	18-72	7/69	72%	76%	C1A, P20
BWP-12/105-D5	±12	±105	75	150	±0.5%	±0.5%	5	4.5-9	60/690	71%	73%	C1A, P20
BWP-12/125-D12	±12	±125	75	150	±0.5%	±0.5%	12	9-18	25/329	74%	76%	C1A, P20
BWP-12/125-D48	±12	±125	75	150	±0.5%	±0.5%	48	18-72	8/81	73%	77%	C1A, P20
BWP-15/85-D5	±15	±85	75	150	±0.5%	±0.5%	5	4.5-9	68/689	72%	74%	C1A, P20
BWP-15/100-D12	±15	±100	75	150	±0.5%	±0.5%	12	9-18	25/329	74%	76%	C1A, P20
BWP-15/100-D48	±15	±100	75	150	±0.5%	±0.5%	48	18-72	8/81	73%	77%	C1A, P20

- ① Typical at T_A = +25°C under nominal line voltage and full-load conditions unless otherwise noted.
- ② Ripple/Noise (R/N) measured over a 20MHz bandwidth.
- ③ Balanced loads, 10% to 100% load.
- ④ Nominal line voltage, no-load/full-load conditions.

PART NUMBER STRUCTURE

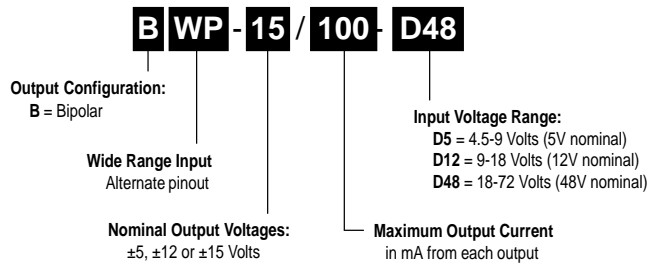

MECHANICAL SPECIFICATIONS

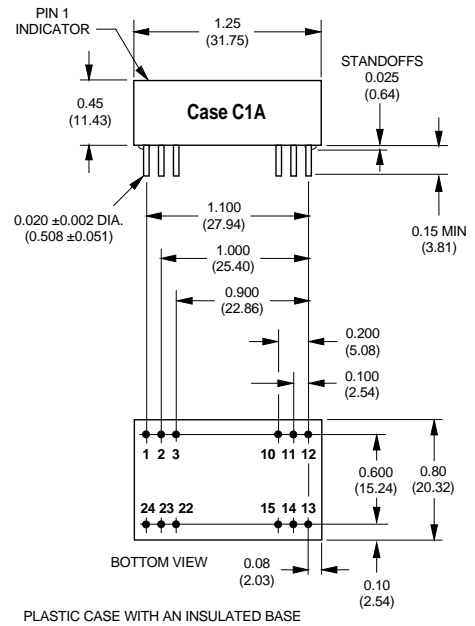

I/O Connections			
Pin	Function P20	Pin	Function P20
1	+Input	13	-Input
2	-Output	14	+Output
3	Common	15	Common
10	Common	22	Common
11	+Output	23	-Output
12	-Input	24	+Input

Performance/Functional Specifications

Typical @ T_A = +25°C under nominal line voltage and full-load conditions unless noted. ①

Input	
Input Voltage Range:	
"D5" Models	4.5-9 Volts (5V nominal)
"D12" Models	9-18 Volts (12V nominal)
"D48" Models	18-72 Volts (48V nominal)
Input Current	See Ordering Guide
Input Filter Type ②	Pi
Reverse-Polarity Protection	Yes (Instantaneous, 2A maximum)
Output	
V_{out} Accuracy (50% load)	±1%, maximum
Temperature Coefficient	±0.02% per °C
Ripple/Noise (20MHz BW) ②	See Ordering Guide
Line/Load Regulation	See Ordering Guide
Efficiency	See Ordering Guide
Isolation Voltage ③	500Vdc, minimum
Current Limiting:	
"D5" Models	Power-limiting technique, auto-recovery
"D12" and "D48" Models	Hiccup technique, auto-recovery
Dynamic Characteristics	
Transient Response (50% load step)	200µsec to ±1.5% of final value
Switching Frequency:	
"D48" Models	200kHz
"D5" and "D12" Models	170kHz
Environmental	
Operating Temperature (Ambient, no derating)	-40 to +75°C
Storage Temperature	-40 to +100°C
Physical	
Dimensions	1.25" x 0.8" x 0.45" (31.8 x 20.3 x 11.4mm)
Case Material	Diallyl phthalate, UL94V-0 rated
Pin Material	Brass, solder coated
Weight	0.5 ounces (14.2 grams)

① These power converters require a minimum 10% loading to maintain specified regulation. Operation under no-load conditions will not damage these devices; however they may not meet all listed specifications.

② Application-specific internal input/output filtering can be recommended and perhaps added internally upon request. Contact DATEL Applications Engineering for details.

③ Devices can be screened or modified for higher guaranteed isolation voltages. Contact DATEL Applications Engineering for details or see DATEL's BST 3W DC/DC's for guaranteed 1000Vdc isolation.

Absolute Maximum Ratings	
Input Voltage:	
"D5" Models	12 Volts
"D12" Models	20 Volts
"D48" Models	80 Volts
Input Reverse-Polarity Protection	Current must be <2A. Brief duration only. Fusing recommended.
Output Overvoltage Protection	None
Output Current	Current limited. Max. current and short-circuit duration are model dependent. "D12" and "D48" models can withstand sustained output short circuits.
Storage Temperature	-40 to +100°C
Lead Temperature (soldering, 10 sec.)	+300°C
These are stress ratings. Exposure of devices to any of these conditions may adversely affect long-term reliability. Proper operation under conditions other than those listed in the Performance/Functional Specifications Table is not implied.	

TECHNICAL NOTES

Floating Outputs

Since these are isolated DC/DC converters, their outputs are "floating." Any BWP model may be configured to produce an output of 10V, 24V or 30V (for ±5V, ±12V or ±15V models, respectively) by applying the load across the +Output (pins 11 and 14) and -Output pins (pins 2 and 23), with either output grounded. The Common (pins 3, 10, 15 and 22) should be left open. Minimum 20% loading is recommended under these conditions.

Filtering and Noise Reduction

All BWP 3 Watt DC/DC Converters achieve their rated ripple and noise specifications without the use of external input/output capacitors. In critical applications, input/output ripple and noise may be further reduced by installing electrolytic capacitors across the input terminals and/or low-ESR tantalum or electrolytic capacitors across the output terminals. Output capacitors should be connected between their respective output pin (pins 2, 11, 14 and 23) and Common (pins 3, 10, 15 and 22) as shown in Figure 2. The caps should be located as close to the power converters as possible. Typical values are listed in the tables below. In many applications, using values greater than those listed will yield better results.

To Reduce Input Ripple

"D5" Models	47µF, 15V
"D12" Models	10µF, 35V
"D48" Models	4.7µF, 100V

To Reduce Output Ripple

±5V Outputs	47µF, 10V, Low ESR
±12/15V Outputs	22µF, 20V, Low ESR

In critical, space-sensitive applications, DATEL may be able to tailor the internal input/output filtering of these units to meet your specific requirements. Contact our Applications Engineering Group for additional details.

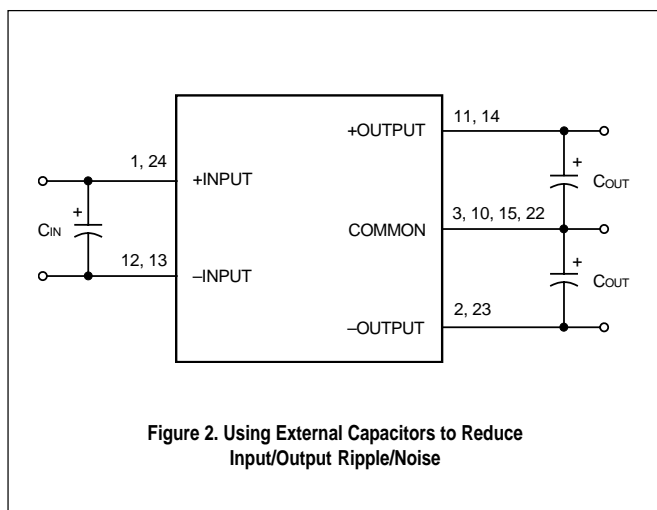

CUSTOM CAPABILITIES

DATEL's world-class design, development and manufacturing team stands ready to work with you to deliver the exact power converter you need for your demanding, large volume, OEM applications. And ... we'll do it on time and within budget!

Our experienced applications and design staffs; quick-turn prototype capability; highly automated, SMT assembly facilities; and in-line SPC quality-control techniques combine to give us the unique ability to design and deliver any quantity of power converters to the highest standards of quality and reliability.

We have compiled a large library of DC/DC designs that are currently used in a variety of telecom, medical, computer, railway, aerospace and industrial applications. We may already have the converter you need.

Contact us. Our goal is to provide you the highest-quality, most cost-effective power converters available.

Input Fusing

Certain applications and/or safety agencies may require the installation of fuses at the inputs of power conversion components. For DATEL BWP 3 Watt DC/DC Converters, you should use slow-blow type fuses with values no greater than the following:

V_{IN} Range	Fuse Value
"D5"	1.5A
"D12"	1A
"D48"	0.5A