



Dual Output BWR Models

Miniature, 1" x 1"
5 Watt, DC/DC Converters

Features

- Small size, 1" x 1" x 0.45"
- Full 5 Watts output power
- No external components required
- Drop-in replacements for many standard, 2" x 1" DC/DC's
- Wide input voltage ranges:
18-36V or 36-72V
- Standard output voltages:
±5, ±12, ±15 Volts
- Guaranteed efficiencies to 80%
- Fully regulated and isolated
(1000Vdc guaranteed)
- Output overvoltage protection and
current limiting
- -25 to +95°C operating temperature
- Shielded cases (5 sides)
- UL1950, CSA 22.2 No. 234, and IEC950
- Modifications and customs for OEM's

The migration to distributed power is accelerating. The critical need for accurate voltages, tight regulation and rapid transient response is propelling the move to power processing at the "point-of-use" with low-power DC/DC converters physically located right at their loads.

DATEL's miniature, full featured, 5 Watt BWR Models were specifically designed for today's demanding distributed power architectures in aerospace, marine, telecom and computer applications. The converters' small size (1" x 1" x 0.45"), full 5 Watt output capability and low cost give system architects unprecedented design and layout flexibility.

Occupying less than 0.5in³ total volume, these extremely compact, fully regulated and isolated (1000Vdc) modules are available with ±5, ±12 or ±15 Volt outputs. Input voltage ranges are either 18-36 Volts ("D24" models) or 36-72 Volts ("D48" models).

Although their overall size is 50-75% smaller than many similarly rated power modules, these 1" x 1" BWR Models are exact, drop-in, pin-for-pin replacements for many standard 2" x 1" and 2" x 2", 5 Watt modules. They achieve their small size and low cost by exploiting a novel feedback approach that does not depend upon traditional optocoupler techniques.

All models are 5-side shielded and have a non-conductive baseplate that permits pc-card runs to be placed beneath the package. Units are assembled using high-speed automated SMT techniques and are fully encapsulated with thermally conductive potting compound. Every unit is electrically tested before and after encapsulation, 100% burned-in under full load, hi-pot tested, and final-electrical tested prior to shipment. Every unit meets DATEL's traditional high standards for quality and long-term reliability.

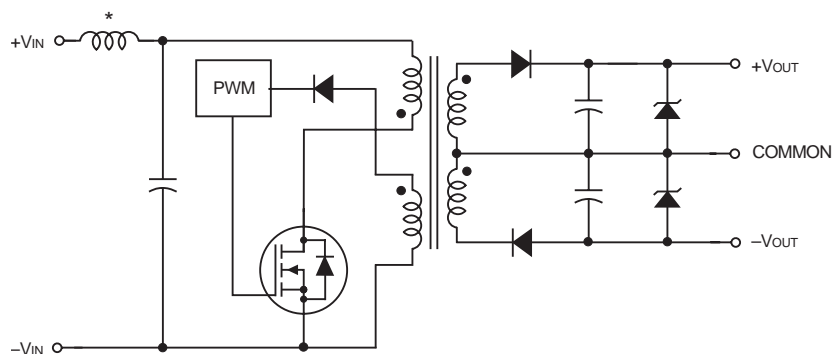

* "D24" models only

Figure 1. Simplified Schematic

Performance Specifications and Ordering Guide ^①

Model	Output					Input			Efficiency (Min.)	Package (Case, Pinout)
	V _{OUT} (Volts)	I _{OUT} (mA, Max.)	Ripple/Noise ^② (mVp-p, Max.)	Regulation (Max.)		V _{IN} Nom. (Volts)	Range (Volts)	I _{IN} ^④ (mA, Max.)		
				Line	Load ^③					
BWR-5/500-D24	± 5	±500	150	±2%	±2%	24	18-36	25/282	75%	C7, P4
BWR-5/500-D48	± 5	±500	120	±2%	±2%	48	36-72	25/141	75%	C7, P4
BWR-12/210-D24	±12	±210	150	±2%	±2%	24	18-36	25/264	80%	C7, P4
BWR-12/210-D48	±12	±210	150	±2%	±2%	48	36-72	25/133	80%	C7, P4
BWR-15/165-D24	±15	±165	150	±2%	±2%	24	18-36	25/260	80%	C7, P4
BWR-15/165-D48	±15	±165	150	±2%	±2%	48	36-72	25/130	80%	C7, P4

- ① Typical at T_A = +25°C under nominal line voltage and full-load conditions unless otherwise noted.
- ② Ripple/Noise (R/N) measured over a 20MHz bandwidth.
- ③ Balanced loads, 20% to 100% load.
- ④ Nominal line voltage, no-load/full-load conditions.

PART NUMBER STRUCTURE

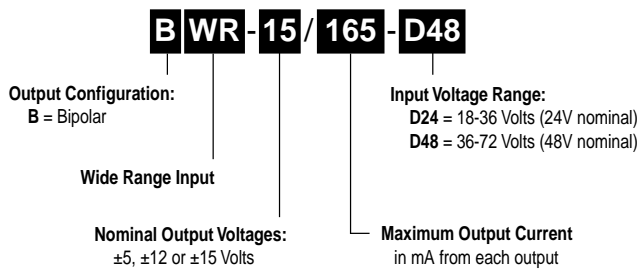

TEMPERATURE DERATING

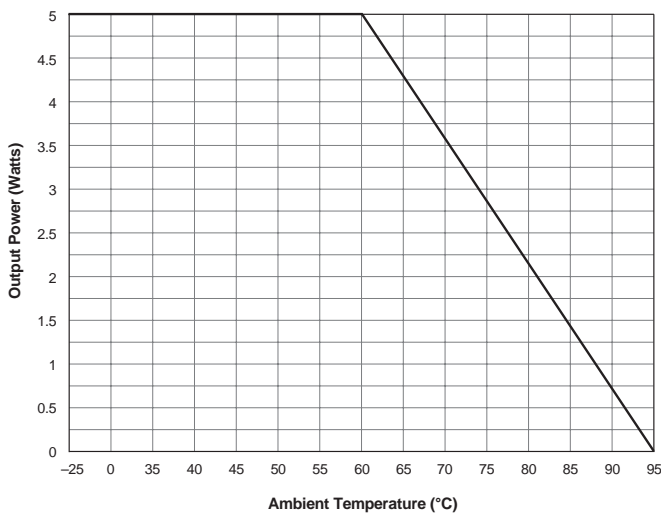

MECHANICAL SPECIFICATIONS

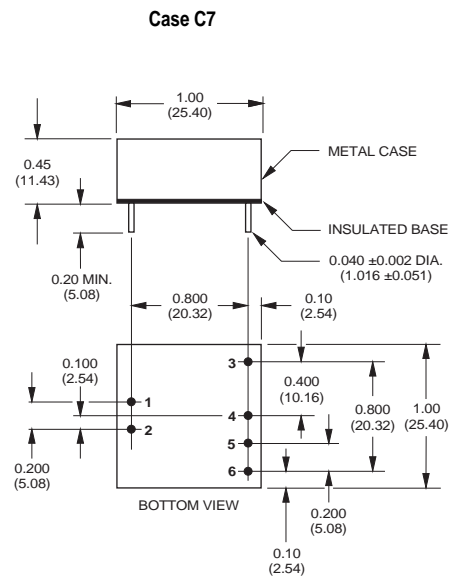

I/O Connections	
Pin	Function P4
1	+Input
2	-Input
3	+Output
4	Common
5	No Pin
6	-Output

Notes:

- For "D24" models, the case is connected to pin 2 (-V_{IN}).
- For "D48" models, the case is connected to pin 1 (+V_{IN}).

Performance/Functional Specifications

Typical @ T_A = +25°C under nominal line voltage and full-load conditions, unless noted. ①

Input	
Input Voltage Range:	
"D24" Models	18-36 Volts (24V nominal)
"D48" Models	36-72 Volts (48V nominal)
Input Current	See Ordering Guide
Input Filter Type ②	LC on "D24" models C on "D48" models
Reverse-Polarity Protection	Yes (Instantaneous, 6A maximum)
OUTPUT	
V_{out} Accuracy (50% load):	
±5V Outputs	±1.5%, maximum
±12/±15V Outputs	±1%, maximum
Temperature Coefficient	±0.02% per °C
Ripple/Noise (20MHz BW) ②	See Ordering Guide
Line Regulation	See Ordering Guide
Load Regulation	See Ordering Guide
Efficiency	See Ordering Guide
Isolation Voltage ③	1000Vdc, minimum
Current Limiting	Auto-recovery
Overvoltage Protection	Zener/transorb clamps
Dynamic Characteristics	
Transient Response (50% load step)	500µsec max. to ±1.5% of final value
Switching Frequency	170kHz (±10kHz)
Environmental	
Operating Temperature (ambient): ④	
Without Derating	-25 to +60°C
With Derating	to +95°C (See Derating Curve)
Storage Temperature	-55 to +125°C
Physical	
Dimensions	1" x 1" x 0.45" (25.4 x 25.4 x 11.4mm)
Shielding	5-sided
Case Connection:	
"D24" Models	Pin 2 (-V _{IN})
"D48" Models	Pin 1 (+V _{IN})
Case Material	Corrosion resistant steel with epoxy-based enamel finish
Pin Material	Brass, solder coated
Weight	0.7 ounces (20 grams)

- ① These power converters require a minimum 20% loading to maintain specified regulation. Operation under no-load conditions will not damage these devices; however they may not meet all listed specifications.
- ② Application-specific internal input/output filtering can be recommended and perhaps added internally on request. Contact DATEL Applications Engineering for details.
- ③ Units can be screened or modified for higher guaranteed isolation voltages. Contact DATEL Applications Engineering for details.
- ④ Units can be screened for lower-temperature operation. Contact DATEL Applications Engineering for details.

ABSOLUTE MAXIMUM RATINGS	
Input Voltage:	
"D24" Models	44 Volts
"D48" Models	88 Volts
Input Reverse-Polarity Protection	Current must be <6A. Brief duration only. Fusing recommended.
Output Overvoltage Protection	
±5V Outputs	6.8 Volts, limited duration
±12V Outputs	15 Volts, limited duration
±15V Outputs	18 Volts, limited duration
Output Current	Current limited. Max. current and short-circuit duration are model dependent.
Storage Temperature	-55 to +125°C
Lead Temperature (soldering, 10 sec.)	+300°C
These are stress ratings. Exposure of devices to any of these conditions may adversely affect long-term reliability. Proper operation under conditions other than those listed in the Performance/Functional Specifications Table is not implied.	

TECHNICAL NOTES

Floating Outputs

Since these are isolated DC/DC converters, their outputs are "floating." Any BWR model may be configured to produce an output of 10V, 24V or 30V (for ±5V, ±12V or ±15V models, respectively) by applying the load across the +Output and -Output (pins 3 and 6), with either output grounded. The Common (pin 4) should be left open. Minimum 20% loading is recommended under these conditions.

Filtering and Noise Reduction

All BWR 5 Watt DC/DC Converters achieve their rated ripple and noise specifications without the use of external input/output capacitors. In critical applications, input/output ripple and noise may be further reduced by installing low-ESR, tantalum or electrolytic capacitors across the input and/or output terminals. Output capacitors should be connected between their respective output pin (pin 3 or 6) and Common (pin 4) as shown in Figure 2. The capacitors should be located as close to the power converters as possible. Typical values are listed below. In many applications, using values greater than those listed will yield better results.

To Reduce Input Ripple

"D24" Models	20µF, 50V
"D48" Models	10µF, 100V

To Reduce Output Ripple

±5V Outputs	47µF, 10V, Low ESR
±12/15V Outputs	33µF, 20V, Low ESR

In critical, space-sensitive applications, DATEL may be able to tailor the internal input/output filtering of these units to meet your specific requirements. Contact our Applications Engineering Group for additional details.

Typical Performance Curves ($T_A = +25^\circ\text{C}$)

The performance curves below were derived from actual test data for a single model number (BWR-15/165-D48). Since all devices in this series have the same circuit topology, the performance curves are representative of all devices.

EFFICIENCY VS. INPUT VOLTAGE AND OUTPUT LOAD

Efficiency vs. Input Voltage

(Full-load conditions. Guaranteed efficiency = 80% at $V_{IN} = 48\text{V}$)

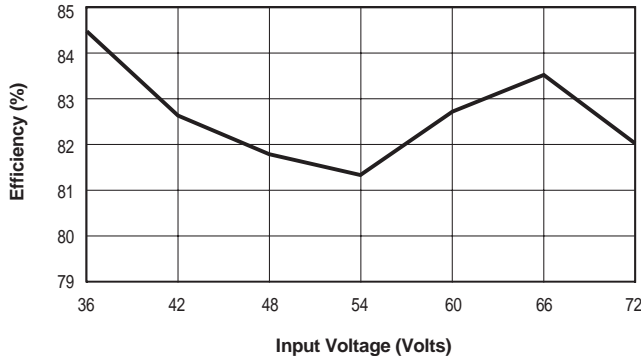

Efficiency vs. Output Load

($V_{IN} = \text{nominal} = 48\text{V}$. Guaranteed efficiency at full load = 80%)

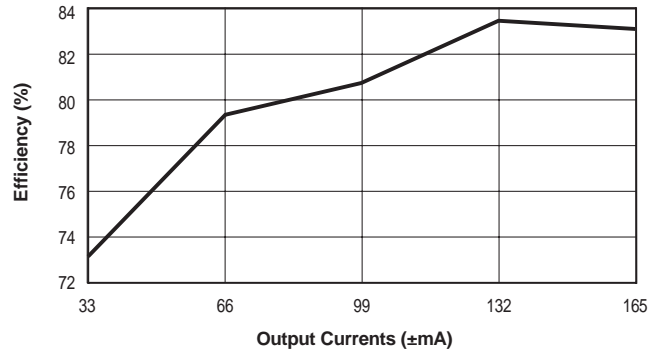

LOAD REGULATION

Output Voltage vs. Load (Balanced)

($V_{IN} = \text{nominal} = 48\text{V}$. Nominal V_{OUT} span = 30V)

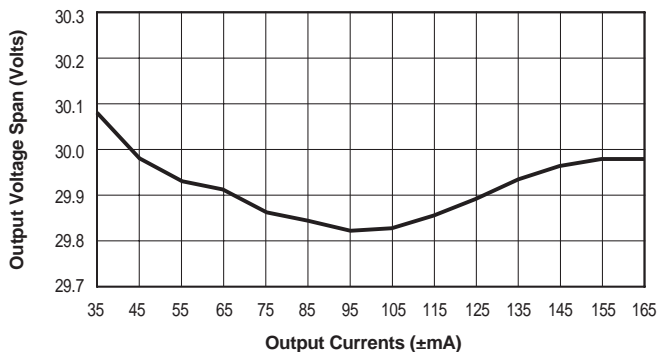

Output Voltage vs. Load (Unbalanced)

($V_{IN} = \text{nominal} = 24\text{V}$. Load on $+V_{OUT}$ fixed at 165mA)

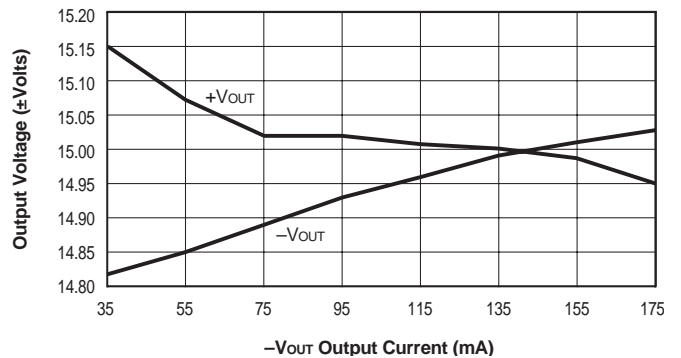

LINE REGULATION

Output Voltage vs. Input Voltage

(Full-load conditions. Nominal V_{OUT} span = 30V)

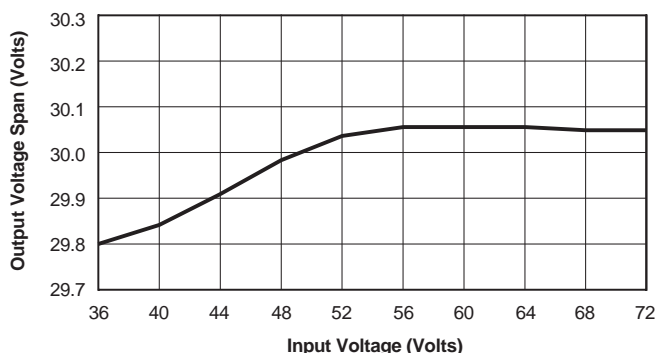

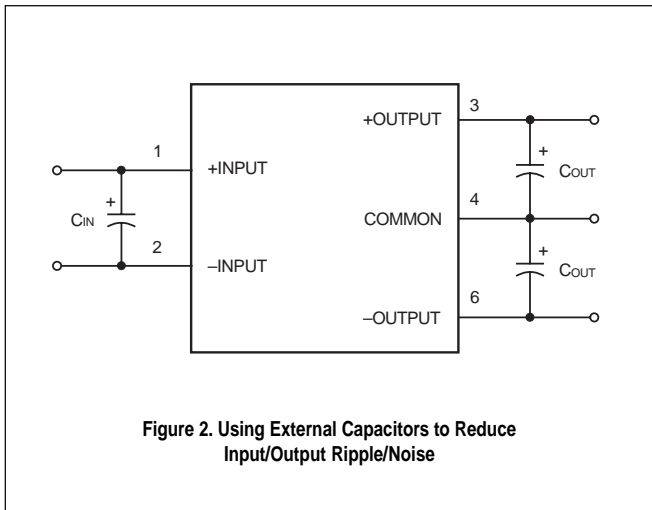

Figure 2. Using External Capacitors to Reduce Input/Output Ripple/Noise

Input Fusing

Certain applications and/or safety agencies may require the installation of fuses at the inputs of power conversion components. For DATEL BWR 5 Watt DC/DC Converters, you should use slow-blow type fuses with values no greater than 0.5A.

CUSTOM CAPABILITIES

DATEL's world-class design, development and manufacturing team stands ready to work with you to deliver the exact power converter you need for your demanding, large volume, OEM applications. And ... we'll do it on time and within budget!

Our experienced applications and design staffs; quick-turn prototype capability; highly automated, SMT assembly facilities; and in-line SPC quality-control techniques combine to give us the unique ability to design and deliver any quantity of power converters to the highest standards of quality and reliability.

We have compiled a large library of DC/DC designs that are currently used in a variety of telecom, medical, computer, railway, aerospace and industrial applications. We may already have the converter you need.

Contact us. Our goal is to provide you the highest-quality, most cost-effective power converters available.

EMI RADIATED EMISSIONS

If you're designing with EMC in mind, please note that all of DATEL's BWR 5 Watt DC/DC Converters have been characterized for radiated and conducted emissions in our new EMI/EMC laboratory. Testing is conducted in an EMCO 5305 GTEM test cell utilizing EMCO automated EMC test software. Radiated emissions are tested to the limits of FCC Part 15, Class B and CISPR 22 (EN 55022) Class B. Correlation to other specifications can be supplied upon request. Radiated emissions plots to FCC and CISPR 22 for model BWR-15/165-D48 appear below. Its performance is typical of all models in the Family. Published EMC test reports are available for each model number. Contact DATEL's Applications Engineering Department for details.

**BWR-15/165-D48 Radiated Emissions
FCC Part 15 Class B, 3 Meters
Converter Output = ±15Vdc @ ±132mA**

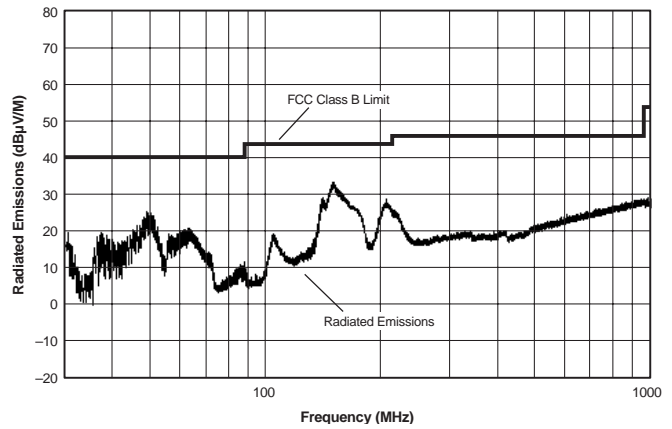

**BWR-15/165-D48 Radiated Emissions
EN 55022 Class B, 10 Meters
Converter Output = ±15Vdc @ ±132mA**

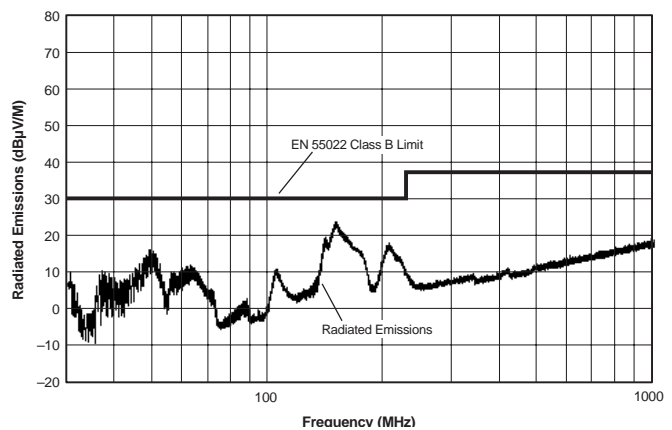



ISO 9001

DS0318 10/98

DATEL, Inc. 11 Cabot Boulevard, Mansfield, MA 02048-1151
Tel: (508) 339-3000 (800) 233-2765
Fax: (508) 339-6356 Email: datellit@mcimail.com
Data Sheet Fax Back: (508) 261-2857

DATEL (UK) LTD. Tadley, England Tel: (01256)-880444
DATEL S.A.R.L. Montigny Le Bretonneux, France Tel: 01-34-60-01-01
DATEL GmbH München, Germany Tel: 89-544334-0
DATEL KK Tokyo, Japan Tel: 3-3779-1031, Osaka Tel: 6-354-2025

DATEL makes no representation that the use of its products in the circuits described herein, or the use of other technical information contained herein, will not infringe upon existing or future patent rights. The descriptions contained herein do not imply the granting of licenses to make, use, or sell equipment constructed in accordance therewith. Specifications are subject to change without notice. The DATEL logo is a registered DATEL, Inc. trademark.