

Purchase On-Line

 www.datel.com

D **DATEL**[®]
INNOVATION and EXCELLENCE

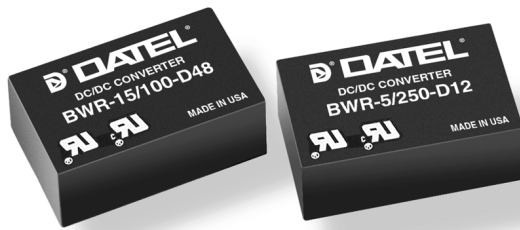

Dual Output BWR Models

Low-Cost, DIP-Packaged 3 Watt, DC/DC Converters

Features

- Low cost!
- Automated, SMT-on-pcb construction
- No external components required
- ± 5 , ± 12 or ± 15 Volt outputs
- Choice of 3 input voltage ranges:
 - 4.5-9 Volts
 - 9-18 Volts
 - 18-72 Volts
- 1.25" x 0.8" x 0.45" DIP form factor
- Industry-standard package and pinout
- Fully isolated, 1000Vdc guaranteed
- Guaranteed efficiencies to 78%
- -25 to +75°C operation with no derating
- UL 1950, CSA 22.2 No. 234 and IEC 950
- EMI/EMC characterized
- Modifications and customs for OEM's

Packaged in industry-standard DIP's, the 3 Watt dual-output models of DATEL's XWR Series DC/DC converters are fully regulated ($\pm 0.5\%$ max. line, $\pm 1\%$ max. load), fully isolated (1000Vdc minimum), extremely efficient (as high as 78% guaranteed) building blocks providing true component-like flexibility and convenience to designers of modern distributed power systems.

Exploiting high-frequency (170-200kHz), flyback topologies and contemporary, highly automated, SMT assembly techniques, BWR Model DC/DC's have enough room to include input (pi type) and output filters within their package. Offering true "plug-and-play" convenience, these power converters require no external components. They operate over the full -25 to +75°C temperature range with no output power derating.

Output voltages are either ± 5 , ± 12 or ± 15 Volts. Input voltage ranges are either 4.5-9V ("D5" models), 9-18V ("D12" models) or an ultra-wide 18-72V ("D48" models). Transient response time is a quick 200 μ sec.

These extremely rugged modules are fully encapsulated with a thermally conductive potting compound. They are moisture and vibration resistant and have established a reputation for outstanding MTBF. For telecommunication, computer and other EMI-sensitive applications, these DIP-packaged DC/DC converters offer full EMI/EMC characterization data.

Industry-standard pinouts make DATEL's BWR Model 3W DC/DC's ideal replacements for other more costly, less reliable power converters. Similarly, they are excellent choices for new design-ins in systems demanding small size, low cost and high reliability.

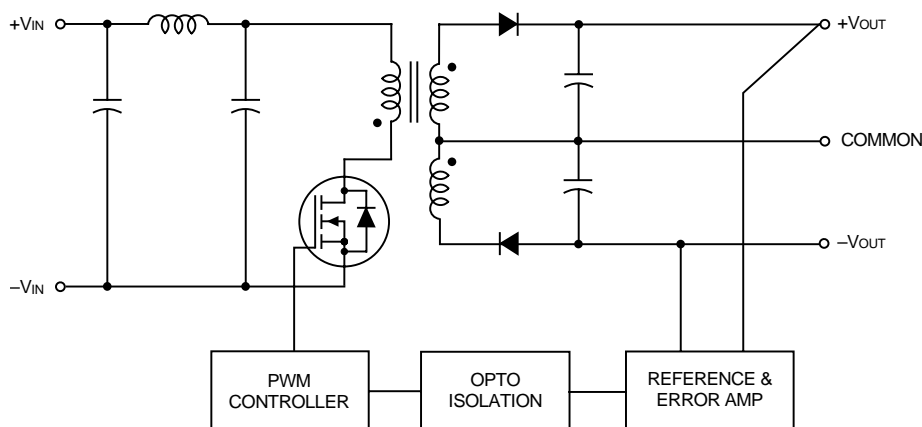

Figure 1. Simplified Schematic

Performance Specifications and Ordering Guide^①

Model	Output						Input			Efficiency		Package (Case, Pinout)
	V _{OUT} (Volts)	I _{OUT} (mA, Max.)	R/N (mVp-p) ②		Regulation (Max.) ③		V _{IN} Nom. (Volts)	Range (Volts)	I _{IN} ④ (mA)	Min.	Typ.	
			Typ.	Max.	Line	Load						
BWR-5/250-D12	±5	±250	75	120	±0.5%	±1.0%	12	9-18	35/278	75%	77%	C1, P2
BWR-5/250-D48	±5	±250	75	120	±0.5%	±1.0%	48	18-72	10/76	75%	77%	C1, P2
BWR-12/105-D5	±12	±105	75	150	±0.5%	±1.0%	5	4.5-9	75/727	70%	72%	C1, P2
BWR-12/125-D12	±12	±125	75	150	±0.5%	±1.0%	12	9-18	35/346	73%	75%	C1, P2
BWR-12/125-D48	±12	±125	75	150	±0.5%	±1.0%	48	18-72	10/81	78%	80%	C1, P2
BWR-15/85-D5	±15	±85	75	150	±0.5%	±0.5%	5	4.5-9	100/736	70%	72%	C1, P2
BWR-15/100-D12	±15	±100	75	150	±0.5%	±1.0%	12	9-18	35/346	73%	75%	C1, P2
BWR-15/100-D48	±15	±100	75	150	±0.5%	±1.0%	48	18-72	10/81	78%	80%	C1, P2

- ① Typical at T_A = +25°C under nominal line voltage and full-load conditions unless otherwise noted.
- ② Ripple/Noise (R/N) measured over a 20MHz bandwidth.
- ③ Balanced loads, 10% to 100% load.
- ④ Nominal line voltage, no-load/full-load conditions.

PART NUMBER STRUCTURE

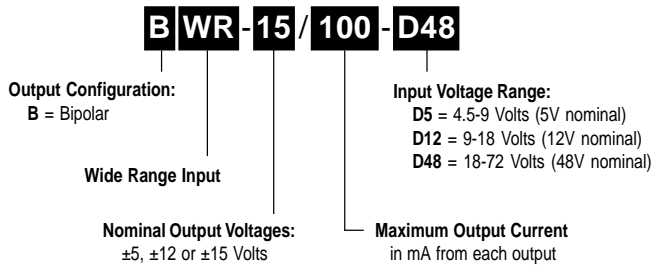

MECHANICAL SPECIFICATIONS

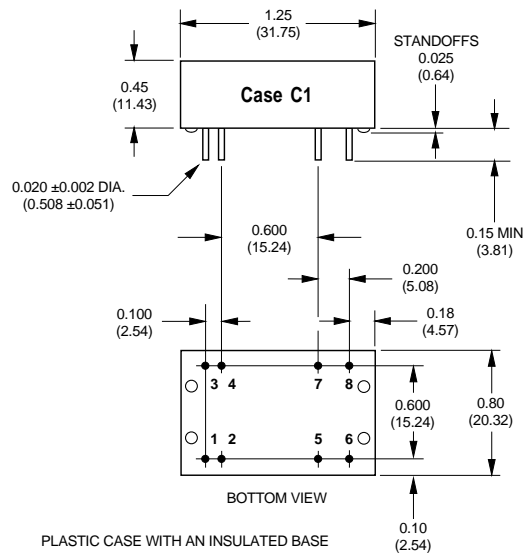

I/O Connections	
Pin	Function P2
1	+Input
2	+Input
3	-Input
4	-Input
5	Common
6	+Output
7	Common
8	-Output

Performance/Functional Specifications

Typical @ T_A = +25°C under nominal line voltage and full-load conditions, unless noted. ①

Input	
Input Voltage Range:	
"D5" Models	4.5-9 Volts (5V nominal)
"D12" Models	9-18 Volts (12V nominal)
"D48" Models	18-72 Volts (48V nominal)
Input Current	See Ordering Guide
Input Filter Type ②	Pi
Reverse-Polarity Protection	Yes (Instantaneous, 2A maximum)
Output	
Vour Accuracy (50% load)	±1%, maximum
Temperature Coefficient	±0.02% per °C
Ripple/Noise (20MHz BW) ②	See Ordering Guide
Line/Load Regulation	See Ordering Guide
Efficiency	See Ordering Guide
Isolation Voltage ③	1000Vdc, minimum
Current Limiting:	
"D5" Models	Power-limiting technique, auto-recovery
"D12" and "D48" Models	Hiccup technique, auto-recovery
Dynamic Characteristics	
Transient Response (50% load step)	200µsec to ±1% of final value
Switching Frequency:	
"D5" Models	200kHz
"D12" and "D48" Models	170kHz
Environmental	
Operating Temperature ④ (Ambient, no derating)	-25 to +75°C
Storage Temperature	-40 to +100°C
Physical	
Dimensions	1.25" x 0.8" x 0.45" (31.8 x 20.3 x 11.4mm)
Case Material	Diallyl phthalate, UL94V-0-rated
Pin Material	Brass, solder coated
Weight	0.5 ounces (14.2 grams)

- ① These power converters require a minimum 10% loading to maintain specified regulation. Operation under no-load conditions will not damage these devices; however they may not meet all listed specifications.
- ② Application-specific internal input/output filtering can be recommended and perhaps added internally upon request. Contact DATEL Applications Engineering for details.
- ③ Devices can be screened or modified for higher guaranteed isolation voltages. Contact DATEL Applications Engineering for details.
- ④ Devices can be warranted or screened for lower-temperature operation. Contact DATEL Applications Engineering for details. See DATEL's new BST 3W Models for guaranteed operation to -40°C.

Absolute Maximum Ratings	
Input Voltage:	
"D5" Models	12 Volts
"D12" Models	20 Volts
"D48" Models	80 Volts
Input Reverse-Polarity Protection	Current must be <2A. Brief duration only. Fusing recommended.
Output Overvoltage Protection	None
Output Current	Current limited. Max. current and short-circuit duration are model dependent. "D12" and "D48" models can withstand sustained output short circuits.
Storage Temperature	-40 to +100°C
Lead Temperature (soldering, 10 sec.)	+300°C
These are stress ratings. Exposure of devices to any of these conditions may adversely affect long-term reliability. Proper operation under conditions other than those listed in the Performance/Functional Specifications Table is not implied.	

TECHNICAL NOTES

Floating Outputs

Since these are isolated DC/DC converters, their outputs are "floating." Any BWR model may be configured to produce an output of 10V, 24V or 30V (for ±5V, ±12V or ±15V models, respectively) by applying the load across the +Output and -Output pins (pins 6 and 8), with either output grounded. The Common (pins 5 and 7) should be left open. Minimum 20% loading is recommended under these conditions.

Filtering and Noise Reduction

All BWR 3 Watt DC/DC Converters achieve their rated ripple and noise specifications without the use of external input/output capacitors. In critical applications, input/output ripple and noise may be further reduced by installing electrolytic capacitors across the input terminals and/or low-ESR tantalum or electrolytic capacitors across the output terminals. Output capacitors should be connected between their respective output pin (pin 6 or 8) and Common (pins 5 and 7) as shown in Figure 2. The caps should be located as close to the power converters as possible. Typical values are listed in the tables below. In many applications, using values greater than those listed will yield better results.

To Reduce Input Ripple

"D5" Models	47µF, 15V
"D12" Models	10µF, 35V
"D48" Models	4.7µF, 100V

To Reduce Output Ripple

±5V Outputs	47µF, 10V, Low ESR
±12/15V Outputs	22µF, 20V, Low ESR

In critical, space-sensitive applications, DATEL may be able to tailor the internal input/output filtering of these units to meet your specific requirements. Contact our Applications Engineering Group for additional details.

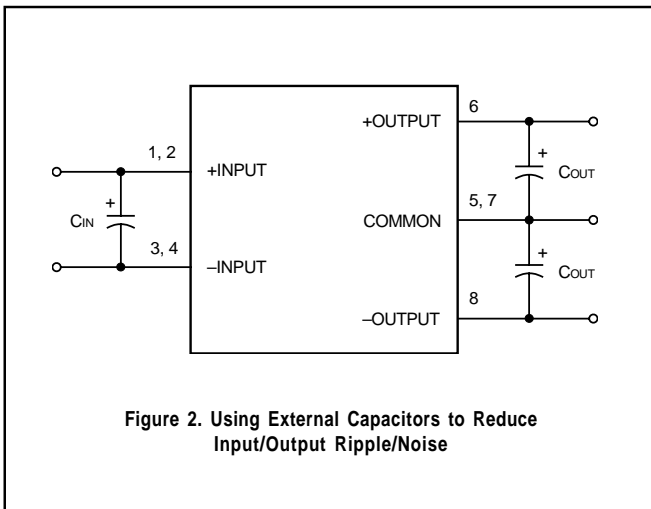

Figure 2. Using External Capacitors to Reduce Input/Output Ripple/Noise

Input Fusing

Certain applications and/or safety agencies may require the installation of fuses at the inputs of power conversion components. For DATEL BWR 3 Watt DC/DC Converters, you should use slow-blow type fuses with values no greater than the following:

V _{IN} Range	Fuse Value
"D5"	1.5A
"D12"	1A
"D48"	0.5A

CUSTOM CAPABILITIES

DATEL's world-class design, development and manufacturing team stands ready to work with you to deliver the exact power converter you need for your demanding, large volume, OEM applications. And ... we'll do it on time and within budget!

Our experienced applications and design staffs; quick-turn prototype capability; highly automated, SMT assembly facilities; and in-line SPC quality-control techniques combine to give us the unique ability to design and deliver any quantity of power converters to the highest standards of quality and reliability.

We have compiled a large library of DC/DC designs that are currently used in a variety of telecom, medical, computer, railway, aerospace and industrial applications. We may already have the converter you need.

Contact us. Our goal is to provide you the highest-quality, most cost-effective power converters available.

EMI RADIATED EMISSIONS

If you're designing with EMC in mind, note that all of DATEL's BWR 3 Watt DC/DC Converters have been characterized for radiated and conducted emissions in our new EMI/EMC laboratory. Testing is conducted in an EMCO 5305 GTEM test cell utilizing EMCO automated EMC test software. Radiated emissions are tested to the limits of FCC Part 15, Class B and CISPR 22 (EN 55022), Class B. Correlation to other specifications can be supplied upon request. Radiated emissions plots to FCC and CISPR 22 for model BWR-5/250-D12 appear below. Published EMC test reports are available for each model number. Contact DATEL's Applications Engineering Department for more details.

**BWR-5/250-D12 Radiated Emissions
FCC Part 15 Class B, 3 Meters
Converter Output = ±5Vdc @ ±203mA**

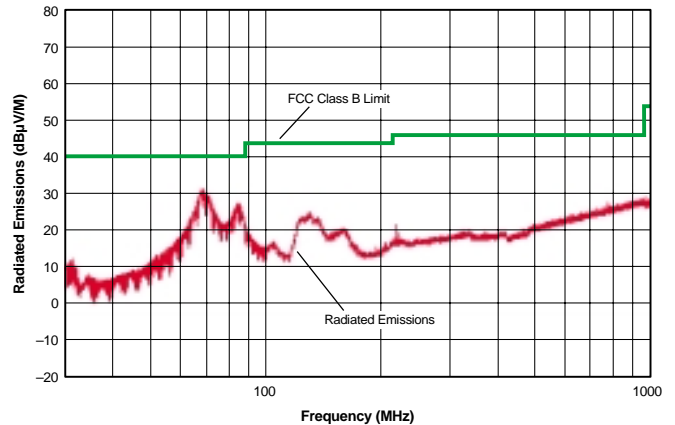

**BWR-5/250-D12 Radiated Emissions
EN 55022 Class B, 10 Meters
Converter Output = ±5Vdc @ ±203mA**

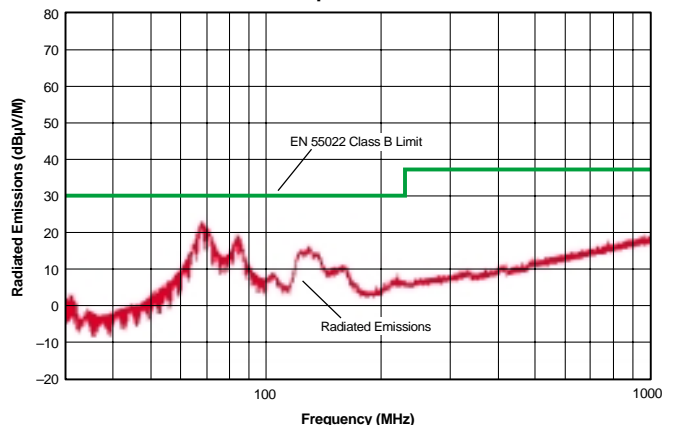

ISO-9001 REGISTERED

DS0317 8/99

DATEL, Inc. 11 Cabot Boulevard, Mansfield, MA 02048-1151
Tel: (508) 339-3000 (800) 233-2765 Fax: (508) 339-6356
Internet: www.datel.com Email: sales@datel.com
Data Sheet Fax Back: (508) 261-2857

DATEL (UK) LTD. Tadley, England Tel: (01256)-880444
DATEL S.A.R.L. Montigny Le Bretonneux, France Tel: 01-34-60-01-01
DATEL GmbH München, Germany Tel: 89-544334-0
DATEL KK Tokyo, Japan Tel: 3-3779-1031, Osaka Tel: 6-354-2025

DATEL makes no representation that the use of its products in the circuits described herein, or the use of other technical information contained herein, will not infringe upon existing or future patent rights. The descriptions contained herein do not imply the granting of licenses to make, use, or sell equipment constructed in accordance therewith. Specifications are subject to change without notice. The DATEL logo is a registered DATEL, Inc. trademark.