



DC COMPONENTS CO., LTD.

RECTIFIER SPECIALISTS

**S1A
THRU
S1M**

TECHNICAL SPECIFICATIONS OF SURFACE MOUNT SILICON RECTIFIER

VOLTAGE RANGE - 50 to 1000 Volts

CURRENT - 1.0 Ampere

FEATURES

- * Ideal for surface mounted applications
- * Low leakage current
- * Glass passivated junction

MECHANICAL DATA

- * Case: Molded plastic
- * Epoxy: UL 94V-0 rate flame retardant
- * Terminals: Solder plated, solderable per MIL-STD-750, Method 2026
- * Polarity: As marked
- * Mounting position: Any
- * Weight: 0.093 gram

MAXIMUM RATINGS AND ELECTRICAL CHARACTERISTICS

Ratings at 25 °C ambient temperature unless otherwise specified.
Single phase, half wave, 60 Hz, resistive or inductive load.
For capacitive load, derate current by 20%.



SMB (DO-214AA)

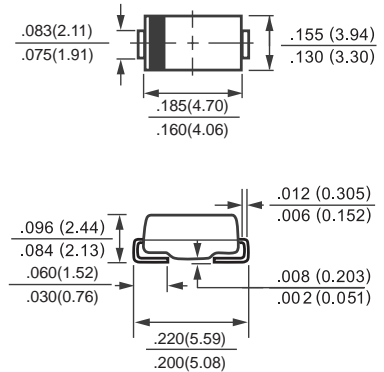

Dimensions in inches and (millimeters)

	SYMBOL	S1A	S1B	S1D	S1G	S1J	S1K	S1M	UNITS
Maximum Recurrent Peak Reverse Voltage	VRRM	50	100	200	400	600	800	1000	Volts
Maximum RMS Voltage	VRMS	35	70	140	280	420	560	700	Volts
Maximum DC Blocking Voltage	Vbc	50	100	200	400	600	800	1000	Volts
Maximum Average Forward Rectified Current at TA = 75 °C	IO	1.0							Amps
Peak Forward Surge Current 8.3 ms single half sine-wave superimposed on rated load (JEDEC Method)	IFSM	30							Amps
Maximum Instantaneous Forward Voltage at 1.0A DC	VF	1.1							Volts
Maximum DC Reverse Current at Rated DC Blocking Voltage	IR	@ TA = 25 °C							uAmps
		@ TA = 100 °C							
Maximum Reverse Recovery Time (Note 3)	trr	2.5							uSec
Typical Thermal Resistance (Note 2)	RθJL	12							°C/W
Typical Junction Capacitance (Note 1)	CJ	30							pF
Operating and Storage Temperature Range	TJ, TSTG	-65 to + 175							°C

- NOTES : 1. Measured at 1 MHz and applied reverse voltage of 4.0 volts.
 2. Thermal Resistance (Junction to Ambient), 0.2x0.2in² (5X5mm²) copper pads to each terminal.
 3. Test Conditions: IF=0.5A, IR=1.0A, IRR=0.25A.

RATING AND CHARACTERISTIC CURVES (S1A THRU S1M)

FIG. 1 - TYPICAL FORWARD CURRENT DERATING CURVE

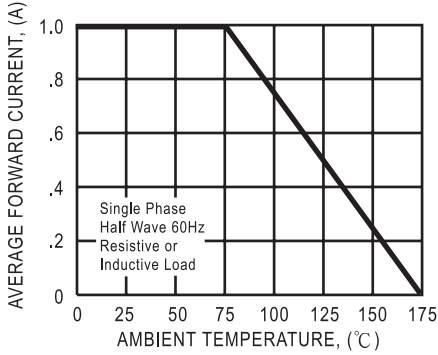

FIG. 2 - MAXIMUM NON-REPETITIVE FORWARD SURGE CURRENT

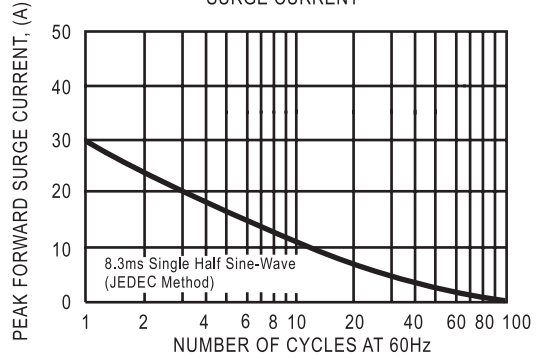

FIG. 3 - TYPICAL INSTANTANEOUS FORWARD CHARACTERISTICS

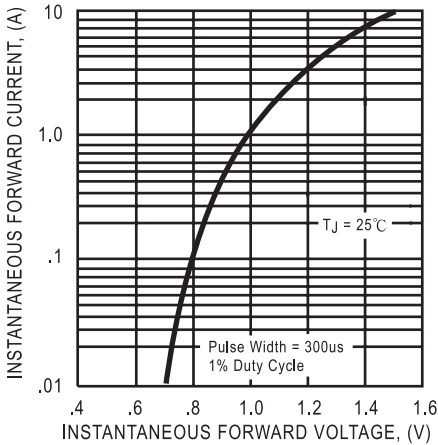

FIG. 4 - TYPICAL REVERSE CHARACTERISTICS

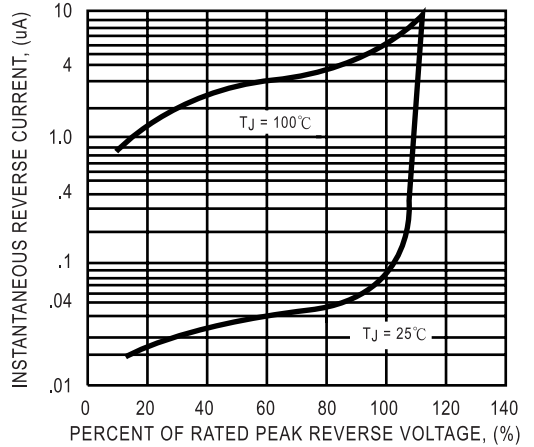
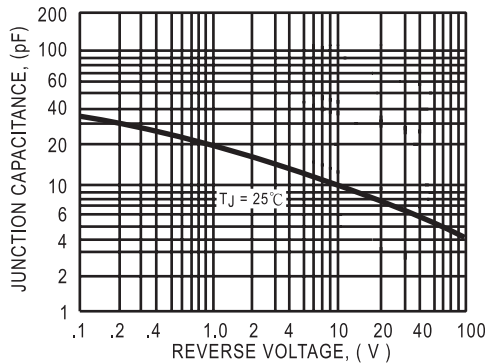

FIG. 5 - TYPICAL JUNCTION CAPACITANCE



DC COMPONENTS CO., LTD.