

Features

- Fast Switching Speed
- Surface Mount Package Ideally Suited for Automatic Insertion
- For General Purpose Switching Applications
- High Conductance

Mechanical Data

- Case: SOT-23, Molded Plastic
- Terminals: Solderable per MIL-STD-202, Method 208
- Polarity: See Diagram
- Marking: KA3
- Weight: 0.008 grams (approx.)

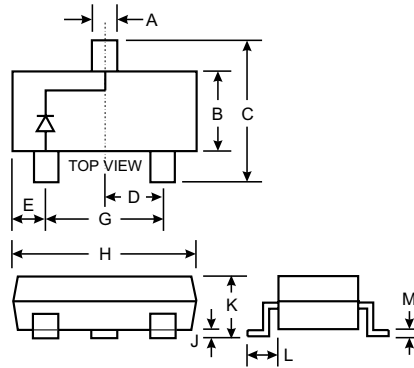

| SOT-23 | | |
|----------------------|-------|-------|
| Dim | Min | Max |
| A | 0.37 | 0.51 |
| B | 1.19 | 1.40 |
| C | 2.10 | 2.50 |
| D | 0.89 | 1.05 |
| E | 0.45 | 0.61 |
| G | 1.78 | 2.05 |
| H | 2.65 | 3.05 |
| J | 0.013 | 0.15 |
| K | 0.89 | 1.10 |
| L | 0.45 | 0.61 |
| M | 0.076 | 0.178 |
| All Dimensions in mm | | |

Maximum Ratings @ $T_A = 25^\circ\text{C}$ unless otherwise specified

| Characteristic | Symbol | MMBD4448 | Unit |
|---|---------------------------------|-------------|------------------|
| Non-Repetitive Peak Reverse Voltage | V_{RM} | 100 | V |
| Peak Repetitive Reverse Voltage Working Peak Reverse Voltage DC Blocking Voltage | V_{RRM} V_{RWM} V_R | 75 | V |
| RMS Reverse Voltage | $V_{R(RMS)}$ | 53 | V |
| Forward Continuous Current (Note 1) | I_{FM} | 500 | mA |
| Average Rectified Output Current (Note 1) | I_O | 250 | mA |
| Non-Repetitive Peak Forward Surge Current @ $t = 1.0\mu\text{s}$ @ $t = 1.0\text{s}$ | I_{FSM} | 4.0 2.0 | A |
| Power Dissipation (Note 1) | P_d | 350 | mW |
| Thermal Resistance Junction to Ambient Air (Note 1) | $R_{\theta JA}$ | 357 | K/W |
| Operating and Storage Temperature Range | T_j, T_{STG} | -65 to +150 | $^\circ\text{C}$ |

Electrical Characteristics @ $T_A = 25^\circ\text{C}$ unless otherwise specified

| Characteristic | Symbol | Min | Max | Unit | Test Condition |
|------------------------------|----------|------|---|---|--|
| Maximum Forward Voltage | V_{FM} | 0.62 | 0.72 — 0.855 — 1.0 — 1.25 | V | $I_F = 5.0\text{mA}$ $I_F = 10\text{mA}$ $I_F = 100\text{mA}$ $I_F = 150\text{mA}$ |
| Maximum Peak Reverse Current | I_{RM} | — | 2.5 50 30 25 | μA μA μA nA | $V_R = 75\text{V}$ $V_R = 75\text{V}, T_j = 150^\circ\text{C}$ $V_R = 25\text{V}, T_j = 150^\circ\text{C}$ $V_R = 20\text{V}$ |
| Junction Capacitance | C_j | — | 4.0 | pF | $V_R = 0, f = 1.0\text{MHz}$ |
| Reverse Recovery Time | t_{rr} | — | 4.0 | ns | $I_F = I_R = 10\text{mA}$, $I_{rr} = 0.1 \times I_R, R_L = 100\Omega$ |

Notes: 1. Valid provided that terminals are kept at ambient temperature.

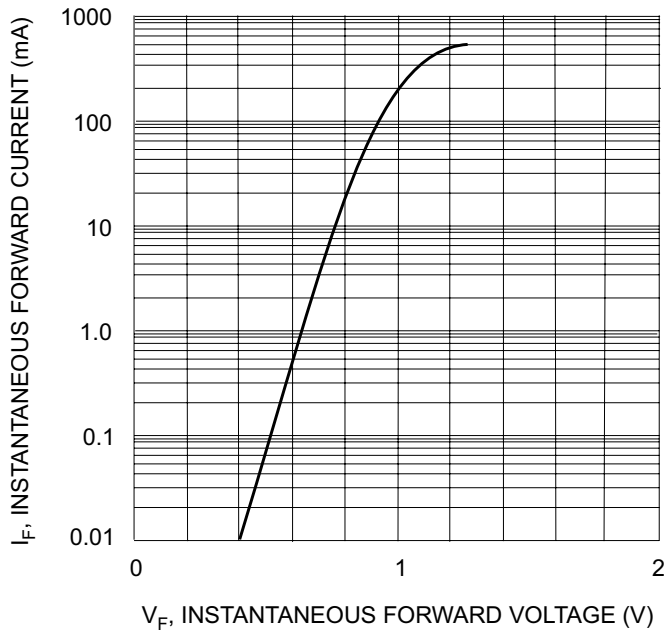

Fig. 1 Forward Characteristics

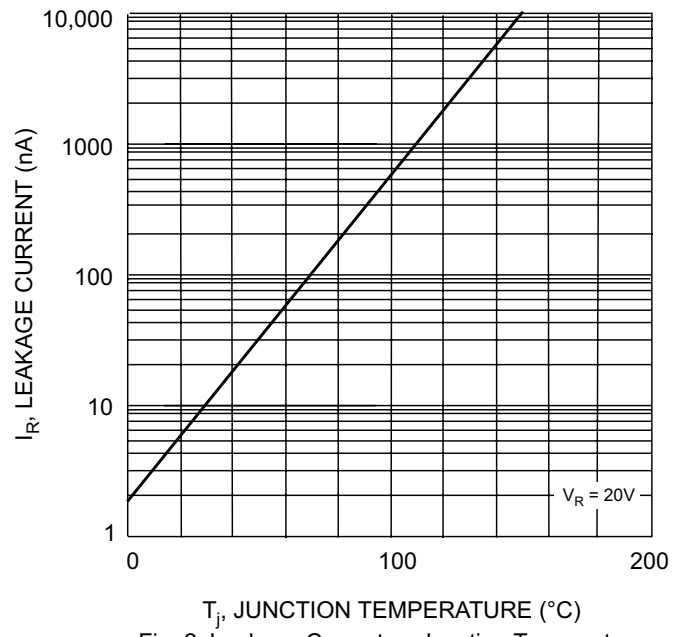

Fig. 2 Leakage Current vs Junction Temperature