

### Features

- 375W Peak Pulse Power Dissipation
- 5.0V - 30V Standoff Voltages
- Glass Passivated Die Construction
- Bi-Directional Device
- Excellent Clamping Capability
- Fast Response Time
- Plastic Material: UL Flammability Classification Rating 94V-0
- Very Low Capacitance

### Mechanical Data

- Case: MiniDIP, Molded Plastic
- Terminals: Solderable per MIL-STD-202, Method 208
- Polarity Indicator: TBD
- Marking: Date Code and Marking Code
- Weight: 0.125 grams (approx.)

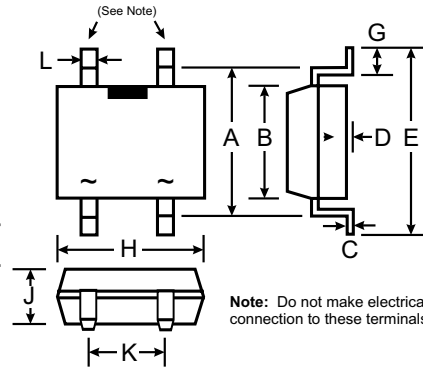

MiniDIP		
Dim	Min	Max
A	5.75	5.43
B	3.6	4.0
C	0.15	0.35
D	0.05	0.20
E	—	7.0
G	0.70	1.10
H	4.5	4.9
J	2.8	2.9
K	2.5	2.7
L	0.50	0.80
All Dimensions in mm		

### Maximum Ratings @ T<sub>A</sub> = 25°C unless otherwise specified

Characteristic	Symbol	Value	Unit
Peak Pulse Power Dissipation (Non repetitive current pulse derated above T <sub>A</sub> = 25°C) (Note 1)	PPK	375	W
Capacitance (Note 2)	C <sub>i</sub>	30	pF
Operating and Storage Temperature Range	T <sub>J</sub> , T <sub>STG</sub>	-55 to +150	°C

### Electrical Characteristics @ T<sub>A</sub> = 25°C unless otherwise specified

Type Number (Note 4)	Reverse Standoff Voltage	Breakdown Voltage V <sub>BR</sub> @ I <sub>T</sub> (Note 3)		Test Current I <sub>T</sub> (mA)	Max. Reverse Leakage @ V <sub>RWM</sub> I <sub>R</sub> (μA)	Max. Clamping Voltage @ I <sub>pp</sub> V <sub>C</sub> (V)	Max. Peak Pulse Current I <sub>pp</sub> (A)	Marking Code
	V <sub>RWM</sub> (V)	Min (V)	Max (V)					
HDC5.0CA	5.0	7.0	7.6	10	50	11.2	40.2	HC5
HDC6.0CA	6.0	7.3	8.0	10	50	12.2	35.9	HC6
HDC7.0CA	7.0	8.4	9.2	10	13	13.9	30.8	HC7
HDC8.0CA	8.0	9.5	10.4	1.0	5.0	15.4	27.2	HC8
HDC10CA	10	11.7	12.9	1.0	5.0	18.7	21.8	HC10
HDC12CA	12	13.9	15.3	1.0	5.0	21.5	18.6	HC12
HDC15CA	15	17.3	19.1	1.0	5.0	26.0	15.2	HC15
HDC18CA	18	20.6	22.7	1.0	5.0	30.7	12.7	HC18
HDC22CA	22	25.0	27.5	1.0	5.0	37.0	10.4	HC22
HDC26CA	26	29.5	33.8	1.0	5.0	43.6	8.8	HC26
HDC30CA	30	33.9	37.4	1.0	5.0	49.8	7.6	HC30

- Notes:
1. Valid provided that the terminals are maintained at a distance of 10mm from case at 25°C.
  2. V<sub>R</sub> = 0V, f = 1.0MHz
  3. V<sub>BR</sub> measured with I<sub>T</sub> current pulse = 300μs
  4. Tolerance; Reverse Standoff Voltage, ± 5%.

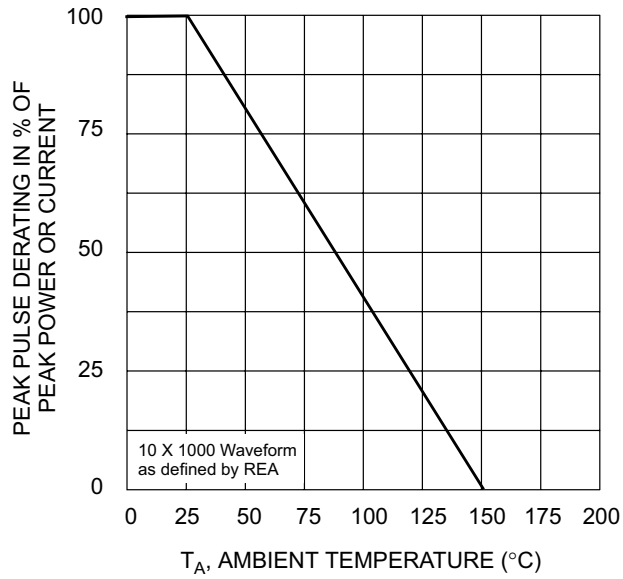

Fig. 1 Pulse Derating Curve

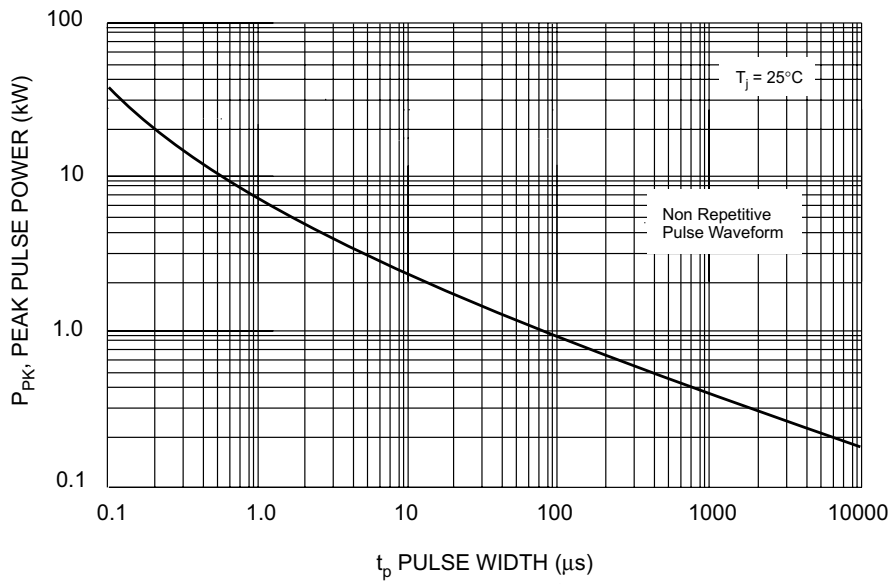

Fig. 2 Pulse Rating Curve

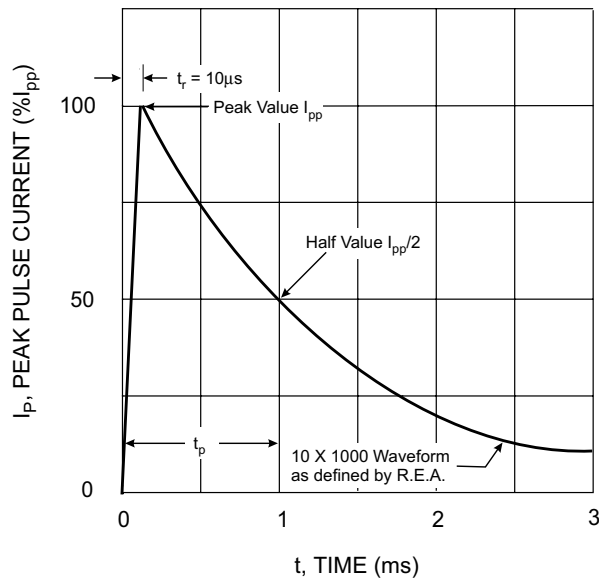

Fig. 3 Pulse Waveform