

COMPLEMENTARY NPN / PNP SMALL SIGNAL SURFACE MOUNT TRANSISTOR

NEW PRODUCT

Features

- Complementary Pair
- One 4124-Type NPN,
One 4126-Type PNP
- Epitaxial Planar Die Construction
- Ideal for Medium Power Amplification and Switching
- Ultra-Small Surface Mount Package

Mechanical Data

- Case: SOT-363, Molded Plastic
- Terminals: Solderable per MIL-STD-202, Method 208
- Terminal Connections: See Diagram
- Marking: K12
- Weight: 0.006 grams (approx.)

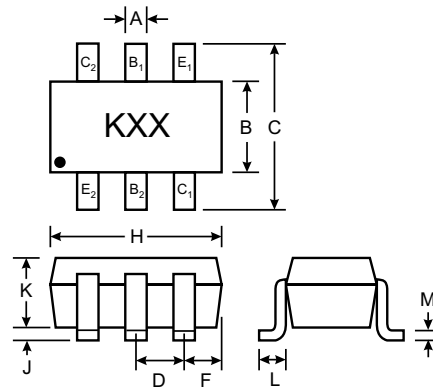

E₁, B₁, C₁ = PNP4126 Section
E₂, B₂, C₂ = NPN4124 Section

SOT-363		
Dim	Min	Max
A	0.10	0.30
B	1.15	1.35
C	2.00	2.20
D	0.65 Nominal	
F	0.30	0.40
H	1.80	2.20
J	—	0.10
K	0.90	1.00
L	0.25	0.40
M	0.10	0.25
All Dimensions in mm		

Maximum Ratings, NPN 4124 Section @ T_A = 25°C unless otherwise specified

Characteristic	Symbol	NPN 4124 Section	Unit
Collector-Base Voltage	V _{CBO}	60	V
Collector-Emitter Voltage	V _{CEO}	40	V
Emitter-Base Voltage	V _{EBO}	6.0	V
Collector Current - Continuous (Note 1)	I _C	200	mA
Power Dissipation (Note 1, 2)	P _d	200	mW
Thermal Resistance, Junction to Ambient (Note 1)	R _{θJA}	625	K/W

Maximum Ratings, PNP 4126 Section @ T_A = 25°C unless otherwise specified

Characteristic	Symbol	PNP 4126 Section	Unit
Collector-Base Voltage	V _{CBO}	-40	V
Collector-Emitter Voltage	V _{CEO}	-40	V
Emitter-Base Voltage	V _{EBO}	-5.0	V
Collector Current - Continuous (Note 1)	I _C	-200	mA
Power Dissipation (Note 1, 2)	P _d	200	mW
Thermal Resistance, Junction to Ambient (Note 1)	R _{θJA}	625	K/W

- Notes: 1. Valid provided that terminals are kept at ambient temperature. Total device dissipation.
2. Maximum combined dissipation.

Electrical Characteristics, NPN 4124 Section @ $T_A = 25^\circ\text{C}$ unless otherwise specified

Characteristic	Symbol	Min	Max	Unit	Test Condition
OFF CHARACTERISTICS (Note 3)					
Collector-Base Breakdown Voltage	$V_{(BR)CBO}$	30	—	V	$I_C = 10\mu\text{A}, I_E = 0$
Collector-Emitter Breakdown Voltage	$V_{(BR)CEO}$	25	—	V	$I_C = 1.0\text{mA}, I_B = 0$
Emitter-Base Breakdown Voltage	$V_{(BR)EBO}$	5.0	6.0	V	$I_E = 10\mu\text{A}, I_C = 0$
Collector Cutoff Current	I_{CBO}	—	50	nA	$V_{CB} = 20\text{V}, I_E = 0\text{V}$
Emitter Cutoff Current	I_{EBO}	—	50	nA	$V_{EB} = 3.0\text{V}, I_C = 0\text{V}$
ON CHARACTERISTICS (Note 3)					
DC Current Gain	h_{FE}	120 60	360 —	—	$I_C = 2.0\text{mA}, V_{CE} = 1.0\text{V}$ $I_C = 50\text{mA}, V_{CE} = 1.0\text{V}$
Collector-Emitter Saturation Voltage	$V_{CE(SAT)}$	—	0.30	V	$I_C = 50\text{mA}, I_B = 5.0\text{mA}$
Base- Emitter Saturation Voltage	$V_{BE(SAT)}$	—	0.95	V	$I_C = 50\text{mA}, I_B = 5.0\text{mA}$
SMALL SIGNAL CHARACTERISTICS					
Output Capacitance	C_{obo}	—	4.0	pF	$V_{CB} = 5.0\text{V}, f = 1.0\text{MHz}, I_E = 0$
Input Capacitance	C_{ibo}	—	8.0	pF	$V_{EB} = 0.5\text{V}, f = 1.0\text{MHz}, I_C = 0$
Small Signal Current Gain	h_{fe}	120	480	—	$V_{CE} = 1.0\text{V}, I_C = 2.0\text{mA},$ $f = 1.0\text{kHz}$
Current Gain-Bandwidth Product	f_T	300	—	MHz	$V_{CE} = 20\text{V}, I_C = 10\text{mA},$ $f = 100\text{MHz}$

Electrical Characteristics, PNP 4126 Section @ $T_A = 25^\circ\text{C}$ unless otherwise specified

Characteristic	Symbol	Min	Max	Unit	Test Condition
OFF CHARACTERISTICS (Note 3)					
Collector-Base Breakdown Voltage	$V_{(BR)CBO}$	-25	—	V	$I_C = -10\mu\text{A}, I_E = 0$
Collector-Emitter Breakdown Voltage	$V_{(BR)CEO}$	-25	—	V	$I_C = -1.0\text{mA}, I_B = 0$
Emitter-Base Breakdown Voltage	$V_{(BR)EBO}$	-4.0	—	V	$I_E = -10\mu\text{A}, I_C = 0$
Collector Cutoff Current	I_{CBO}	—	-50	nA	$V_{CB} = -20\text{V}, I_E = 0\text{V}$
Emitter Cutoff Current	I_{EBO}	—	-50	nA	$V_{EB} = -3.0\text{V}, I_C = 0\text{V}$
ON CHARACTERISTICS (Note 3)					
DC Current Gain	h_{FE}	120 60	360 —	—	$I_C = -2.0\text{mA}, V_{CE} = -1.0\text{V}$ $I_C = -50\text{mA}, V_{CE} = -1.0\text{V}$
Collector-Emitter Saturation Voltage	$V_{CE(SAT)}$	—	-0.40	V	$I_C = -50\text{mA}, I_B = -5.0\text{mA}$
Base- Emitter Saturation Voltage	$V_{BE(SAT)}$	—	-0.95	V	$I_C = -50\text{mA}, I_B = -5.0\text{mA}$
SMALL SIGNAL CHARACTERISTICS					
Output Capacitance	C_{obo}	—	4.5	pF	$V_{CB} = -5.0\text{V}, f = 1.0\text{MHz}, I_E = 0$
Input Capacitance	C_{ibo}	—	10	pF	$V_{EB} = -0.5\text{V}, f = 1.0\text{MHz}, I_C = 0$
Small Signal Current Gain	h_{fe}	120	480	—	$V_{CE} = -1.0\text{V}, I_C = -2.0\text{mA},$ $f = 1.0\text{kHz}$
Current Gain-Bandwidth Product	f_T	250	—	MHz	$V_{CE} = -20\text{V}, I_C = -10\text{mA},$ $f = 100\text{MHz}$
Noise Figure	NF	—	4.0	dB	$V_{CE} = -5.0\text{V}, I_C = -100\mu\text{A},$ $R_S = 1.0\text{k}\Omega, f = 1.0\text{kHz}$

Notes: 3. Pulse test: Pulse width $\leq 300\mu\text{s}$, duty cycle $\leq 2\%$.