

The purpose of the MA1916 is to encode serial data to allow error correction when the data is transmitted over a noisy communication link. As the name suggests, the unit contains two encoding elements. The Reed-Solomon encoder appends a checksum to a block of data, guarding against burst errors in a message. The convolution encoder continuously creates two code bits for each data bit it receives, increasing the noise immunity by doubling the band width of the message. The unit also contains a test pattern generator which can be connected to check the functionality of the RS encoder and to provide a message timing signal (SMC\_OUT).

Protection against a long error-burst can be increased by interleaving a number of message packets passing through the RS encoder. The MA1916 provides pin selectable interleave depths of 1, 4 or 5. Interleave depths of greater than 5 do not significantly improve performance.

The MA1916 is designed to conform to the CCSDS standard for telemetry 101.0.B.2. It is manufactured in a radiation hard low power CMOS technology. This makes it ideal for use in satellite communications systems. The encoder reduces the risk of data corruption and allows the designer to minimize the transmitter power needed to establish an effective communications link.

**FEATURES**

- Radiation Hard CMOS-SOS Technology
- Low Power Consumption
- Latch-up Free
- High SEU Immunity
- CCSDS Standard RS (255, 223)
- Selectable Interleave Depths of 1, 4 or 5
- 5MBit/sec Input Data Rate

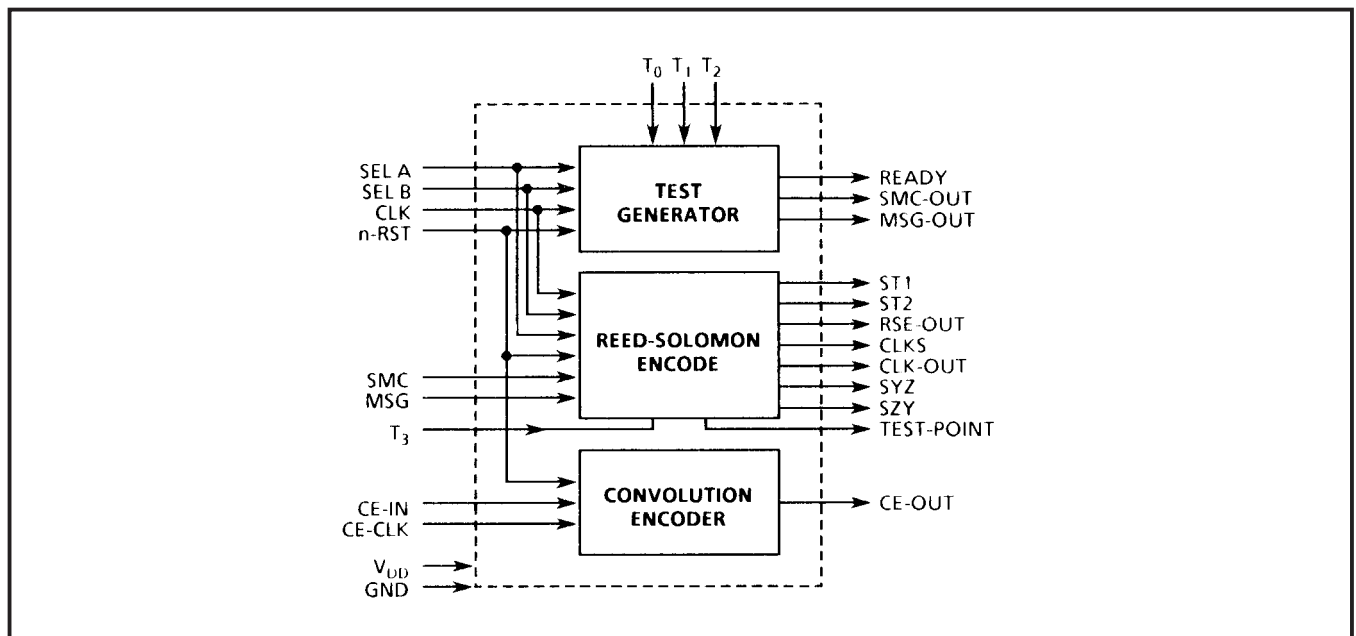

Figure 1: Block Diagram

OPERATION

REED-SOLOMON ENCODER

The function of the Reed-Solomon (RS) encoder is to take a block of 223 bytes of serial data and to append a checksum of 32 bytes. The purpose of the checksum is to allow error correction within the data block. One important feature of the Reed-Solomon algorithm is that it allows correction of a burst error which corrupts upto 16 consecutive bytes. If a number of messages are interleaved this length can be increased. The MA1916 provides pin selectable interleave depths of 1, 4 or 5 blocks (see Table 1), each of 223 bytes. An interleave depth of 5 is the maximum recommended by the CCSDS standard. This will allow correction of up to 80 sequential bytes in a data packet.

The RS encoder operates from a clock input CLK which must be driven at twice the input data rate. Internally CLK is divided to give a clock CLKS which runs at half the frequency. This signal is available as an output and is used to time data into the RS encoder.

A high input on SMC is used to tell the RS encoder that data to be encoded is present on the MSG pin (see Figure 2).

While SMC is high the data on MSG is buffered and appears on RSE\_OUT as well as being clocked into the encoder. As soon as SMC goes low the checksum is clocked out of the encoder onto RSE\_OUT.

While SMC is high the RSE\_OUT signal follows the input MSG. When SMC is low RSE\_OUT is produced from the exclusive-OR of MSG and the checksum signal. For this reason MSG must be held low while the encoder outputs the checksum.

A gap can be left between successive data packets by holding SMC and MSG low after the checksum has been sent. Alternatively, synchronisation code can be inserted before a data block by holding SMC low and placing the code on MSG. As soon as SMC goes high any further data on MSG is assumed to form part of a message and will be encoded accordingly.

**Note:** External logic must guarantee the SMC is high for the correct period, ie only while 223 x I bytes (I = interleave depth) of data are clocked through. Otherwise when SMC falls an invalid checksum will be produced.

SEL_A	SEL_B	Interleave I = Depth	SMC_OUT Period (Bytes)	
			SMC_OUT = 1	SMC_OUT = 0
0	0	5	5 x 223	5 x 32
0	1	4	4 x 223	4 x 32
1	0	1	1 x 223	1 x 32
1	1	5	5 x 223	5 x 32

Table 1: Interleave Length Defined by SEL\_A and SEL\_B

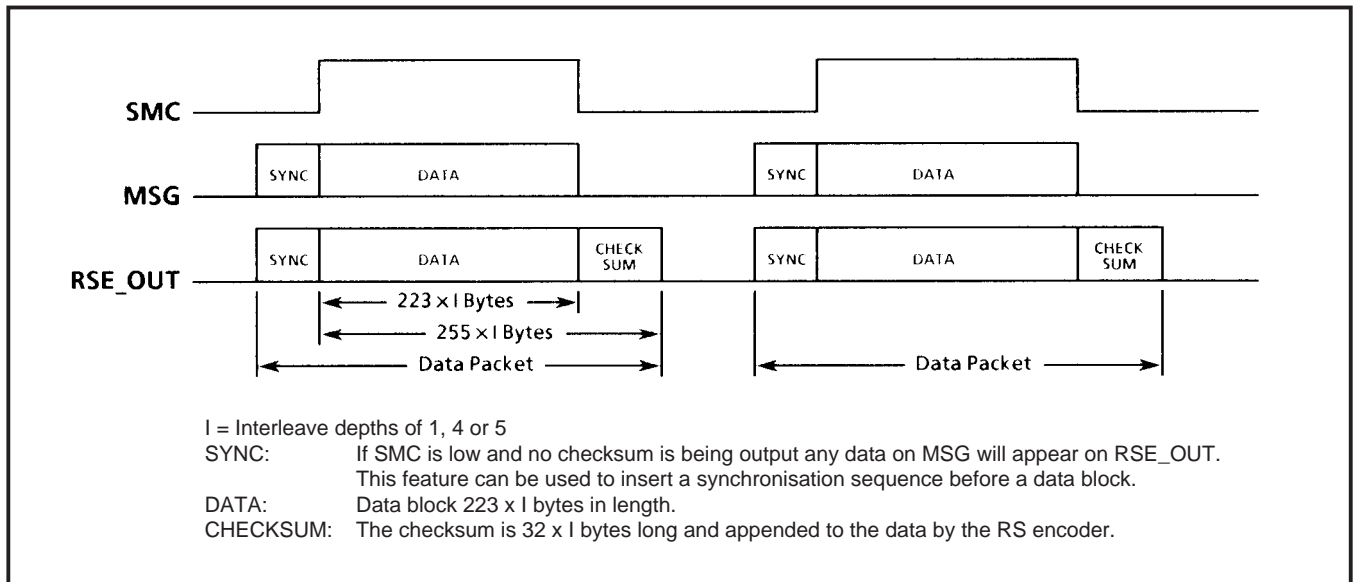

Figure 2: Reed-Solomon Encoder Operation

**CONVOLUTION ENCODER**

The convolution encoder generates 2 serial bits of output data for each bit it reads in. The coding operates cyclically over a length of 7 bits. It increases the bandwidth of the signal but establishes a correlation between successive bits in the output signal.

The convolution encoder operates continuously using CE\_CLK to read data in on CE\_IN and to write the encoded data to CE\_OUT.

If required the output of the Reed-Solomon encoder can be fed directly into the convolution encoder by connecting RSE\_OUT to CE\_IN and CLKS to CE\_CLK.

**TEST GENERATOR**

The MA1916 contains its own built-in test pattern generator, this can be connected to the RS encoder for in service testing. The test generator supplies test patterns and the SMC signal according to the inputs on T0-2 (see Table 2) and the interleave depth selected using SEL\_A and SEL\_B.

Figure 3 shows the necessary connections for feeding test patterns through both the RS and the convolution encoder.

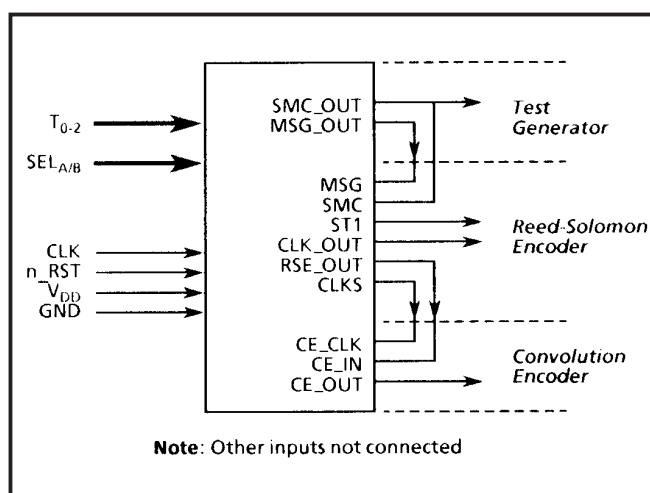

**Note:** Other inputs not connected

**Figure 3: Test Configuration**

T2	T1	T0	Test	Interleave Depth		
				I = 5 (1115 bytes)	I = 4 (892 bytes)	I = 1 (223 bytes)
0	0	0	N/A			0
0	0	1	1	(1, 2, 3, 4, 5) x 223	(1, 2, 3, 4) x 223	(1) x 223
0	1	0	2	(0) x 222 x 5, (0) x 4, (7B)	(0) x 222 x 4, (0) x 3, (7B)	(0) x 222, 7B
0	1	1	3	(0) x 222 x 5, (7B, AF, 99, FA, B7)	(0) x 222 x 4, (7B, AF, 99, FA)	(0) x 222, 7B
1	0	0	4	(0) x 221 x 5, (7B) x 5, (47) x 5	(0) x 221 x 4, (7B) x 4, (47) x 4	(0) x 222, 7B
	Other		N/A			

**Table 2: Test Pattern on MSG\_OUT Defined by T0-2**

**PIN DESCRIPTION**

**V<sub>DD</sub> and GND (Power and Ground)**

The MA1916 uses a single power supply of 5V ±10%.

**CLK (Clock)**

This input supplies a clock signal to the RS encoder and the Test generator. It requires a signal with a nominal 50% duty cycle running at twice the input data rate for the RS encoder. The rising edge of CLK is used to generate the internal CLKS signal which clocks data through the RS encoder.

**n\_RST (Reset)**

This active low signal is a reset supplied to the RS encoder, the test generator and the convolution encoder. It should be noted that the reset does not clear the check sum in the RS encoder and a complete dummy data packet should be run through before valid data is sent.

**SEL\_A and SEL\_B (Interleave Depth Select)**

These inputs define the interleave depth of a message passing through the RS encoder. They also specify the message length to be produced by the test generator (see Table 1). The inputs are connected to internal pulldown resistors.

**T<sub>0-2</sub> (Test Pattern Select)**

These inputs select the pattern to be produced by the test generator (see Table 2). Each input is connected to an internal pull-down resistor.

**T<sub>3</sub> (Production Test Input)**

This input is used for production testing only. It has an internal pull-down resistor and should be left unconnected.

**MSG\_OUT (Test Message Output)**

This output pin carries the test patterns defined by the inputs T<sub>0-2</sub> and produced by the test generator. This signal can be connected directly to MSG for testing purposes.

# MA1916

## SMC\_OUT (Select Message or Checksum)

This output signal is held high while the test generator clocks out a data packet on the MSG\_OUT pin. When the packet is complete this signal goes low. It is held low for a period equal to the time required by the RS encoder to send the corresponding checksum. When this is complete the signal goes high and the test generator begins a new data packet. This signal can be connected directly to SMC for testing purposes.

## READY (Test Data Valid)

This output is held low during reset and remains low for the first complete cycle of SMC\_OUT. READY rises on the second rising edge of SMC\_OUT and remains high to indicate the presence of valid data on MSG\_OUT.

## CLKS (Synchronisation Clock)

This output clock runs at half the speed of the input clock CLK. CLKS remains low after n\_RST is raised until SMC is raised, SMC being captured on the falling edge of CLK (timing 4). CLKS then changes state on the rising edge of each CLK cycle regardless of the state of SMC. The signal is used to clock data into and out of the RS encoder.

## MSG (Message)

MSG is the data input to the RS encoder. Each bit is read in on the rising edge of CLKS. While the SMC signal is high data on the input passes directly to the output RSE\_OUT. While SMC is low RSE\_OUT is the logical XOR of the MSG input and the output of the check-sum generator. Therefore MSG must be held low while the RS encoder is clocking out the check sum (see Figure 4).

## SMC (Select Message or Checksum)

While the SMC input is high, data on the MSG pin is clocked into the RS encoder. SMC is held high for a period dictated by the interleave depth being used (see Table 1). When SMC falls the RS encoder begins to clock out the checksum for the preceeding data. SMC should be held low until the complete checksum has been output. The rising edge of SMC indicates the start of a new data block to be encoded.

## RSE\_OUT (Reed-Solomon Encoder Output)

This signal outputs the completed data packet comprised of the message followed by its associated checksum block. The data is valid on the rising edge of CLKS.

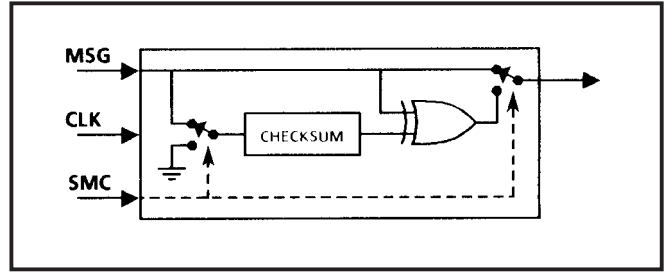

Figure 4: Reed-Solomon Encoder

## ST1 (RS Encoder Output Valid)

This output is set low during a reset and goes high when sufficient dummy data has been clocked through the RS encoder to clear it (see Figure 5).

## SYZ (Byte Rate Clock)

SYZ is a byte rate clock output derived from CLKS. It is high during every eighth period of CLKS and low at other times.

## SZY (Byte Rate Clock)

SZY is a byte rate clock output derived from CLKS. It is low during every eighth period of CLKS and high at other times. It is the inverse of SYZ.

## ST2 (Production Test Output)

The output is used for production testing and should be left unconnected.

## TEST\_POINT (Production Test Output)

This output is used for production testing and should be left unconnected.

## CE\_IN (Convolution Encoder Data In)

This input is used to read data into the convolution encoder. The state of CE\_IN is read on the rising edge of CE\_CLK.

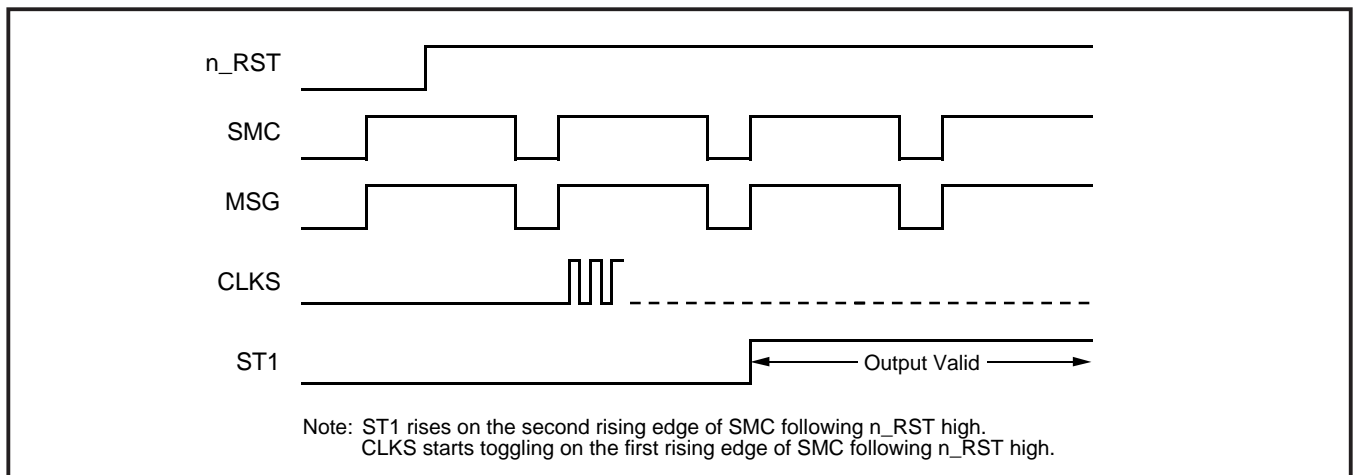

Figure 5: Reed-Solomon Encoder Operation

**CE\_CLK (Convolution Encoder Clock)**

The CE\_CLK input drives the timing of the convolution encoder. Data is read in on CE\_IN on the rising edge of CE\_CLK and output on CE\_OUT on both the rising and falling edge of CE\_CLK.

**Note:** The output data rate is twice the input data rate.

A 50% duty cycle clock is required. If this is provided by the CLKS output, data can be read directly from RSE\_OUT to the CE\_IN input (see figure 3).

**CE\_OUT (Convolution Encoder Output)**

This signal carries the output data from the convolution encoder. The data rate on CE\_OUT is twice that of CE\_IN.

**CLK\_OUT (Clock Out)**

CLK\_OUT is a buffered output of the CLK input signal. If CLKS is connected to CE\_CLK to drive the convolution encoder, CE\_OUT can be captured on the falling edge of CLK\_OUT.

**DC CHARACTERISTICS AND RATINGS**

Parameter	Min	Max	Units
Supply Voltage	-0.5	7	V
Input Voltage	-0.3	$V_{DD}+0.3$	V
Current Through Any Pin	-20	+20	mA
Operating Temperature	-55	125	°C
Storage Temperature	-65	150	°C

**Note:** Stresses above those listed may cause permanent damage to the device. This is a stress rating only and functional operation of the device at these conditions, or at any other condition above those indicated in the operations section of this specification, is not implied. Exposure to absolute maximum rating conditions for extended periods may affect device reliability.

**Table 3: Absolute Maximum Ratings**

Symbol	Parameter	Conditions	Min	Typ	Max	Units
$V_{DD}$	Supply Voltage	-	4.5	5.0	5.5	V
$V_{IH}$	CMOS Input High Voltage	$V_{DD} = 5.5V$	$0.8 V_{DD}$	-	$V_{DD}$	V
$V_{IL}$	CMOS Input Low Voltage	$V_{DD} = 5.5V$	$V_{SS}$	-	$0.2 V_{DD}$	V
$V_{OH}$	CMOS Output High Voltage	$V_{DD} = 5V, I_{OH} = -1.0mA$	$V_{DD}-0.5$	-	-	V
$V_{OL}$	CMOS Output Low Voltage	$V_{DD} = 5V, I_{OL} = 4.0mA$	-	-	0.4	V
$I_{IL}$	Input Leakage Current	$V_{DD} = 5.5V, V_{IN} = V_{SS} \text{ or } V_{DD}$	-10	-	10	$\mu A$
$I_{PDL}$	Input Pull-Down Current	$V_{DD} = 5.5V, V_{IN} = V_{SS} \text{ or } V_{DD}$	-20	-	150	$\mu A$
$I_{DD1}$	Static Power Supply Current	$V_{DD} = 5.5V$	-	0.1	2.5	mA
$I_{DD2}$	Dynamic Power Supply Current	CLK = 10MHZ, $V_{DD} = 5.5V$	-	3	10	mA

**Notes:** 1.  $V_{DD} = 5V \pm 10\%$ , over full operating temperature range. 2. Total dose radiation not exceeding  $1 \times 10^5$  Rads(Si)  
3. Mil-Std-883, method 5005, subgroups 1, 2, 3

**Table 4: DC Electrical Characteristics**

**AC CHARACTERISTICS**

No.	Parameter	Min.	Max.	Units
1	CLK high to CLKS	-	25	ns
2	CLK high to SYZ or SZY	-	30	ns
3	SMC hold after CLK low	0	-	ns
4	SMC setup to CLK low	30	-	ns
5	MSG set up to CLKS high	10	-	ns
6	MSG hold after CLKS high	10	-	ns
7	MSG to RSE_OUT propagation delay	-	30	ns
8	CLKS to RSE_OUT (SMC low)	-	25	ns
9	CLK to CLK_OUT propagation delay	-	25	ns
10	CE_IN setup to CE_CLK high	10	-	ns
11	CE_IN hold after CE_CLK high	10	-	ns
12	CE_CLK to CE_OUT	-	25	ns
13	CLK CYCLE TIME	100	-	ns

**Note:** Mil-Std-883, method 5005, subgroups 9, 10, 11

**Table 5: AC Electrical Characteristics**

# MA1916

Symbol	Parameter	Conditions	Min.	Typ.	Max.	Units
C <sub>IN</sub>	Input Capacitance	V <sub>I</sub> = 0V	-	3	5	pF
C <sub>OUT</sub>	Output Capacitance	V <sub>I/O</sub> = 0V	-	5	7	pF

Note: T<sub>A</sub> = 25°C and f = 1MHz. Data obtained by characterisation or analysis; not routinely measured.

**Table 6: Capacitance**

Symbol	Parameter	Conditions
F <sub>T</sub>	Functionality	V <sub>DD</sub> = 4.5V - 5.5V, Frequency = 1MHz V <sub>IL</sub> = V <sub>SS</sub> , V <sub>IH</sub> = V <sub>DD</sub> , V <sub>OL</sub> = V <sub>OH</sub> = V <sub>DD</sub> /2 Temperature = -55°C to +125°C, Radiation to 1MRad Total Dose Mil-Std-883, method 5005, subgroups 7, 8A, 8B

**Table 7: Functionality**

Subgroup	Definition
1	Static characteristics specified in Table 4 at +25°C
2	Static characteristics specified in Table 4 at +125°C
3	Static characteristics specified in Table 4 at -55°C
7	Functional characteristics specified in Table 7 at +25°C
8A	Functional characteristics specified in Table 7 at +125°C
8B	Functional characteristics specified in Table 7 at -55°C
9	Switching characteristics specified in Table 5 at +25°C
10	Switching characteristics specified in Table 5 at +125°C
11	Switching characteristics specified in Table 5 at -55°C

**Table 8: Definition of Subgroups**

TIMING DIAGRAMS

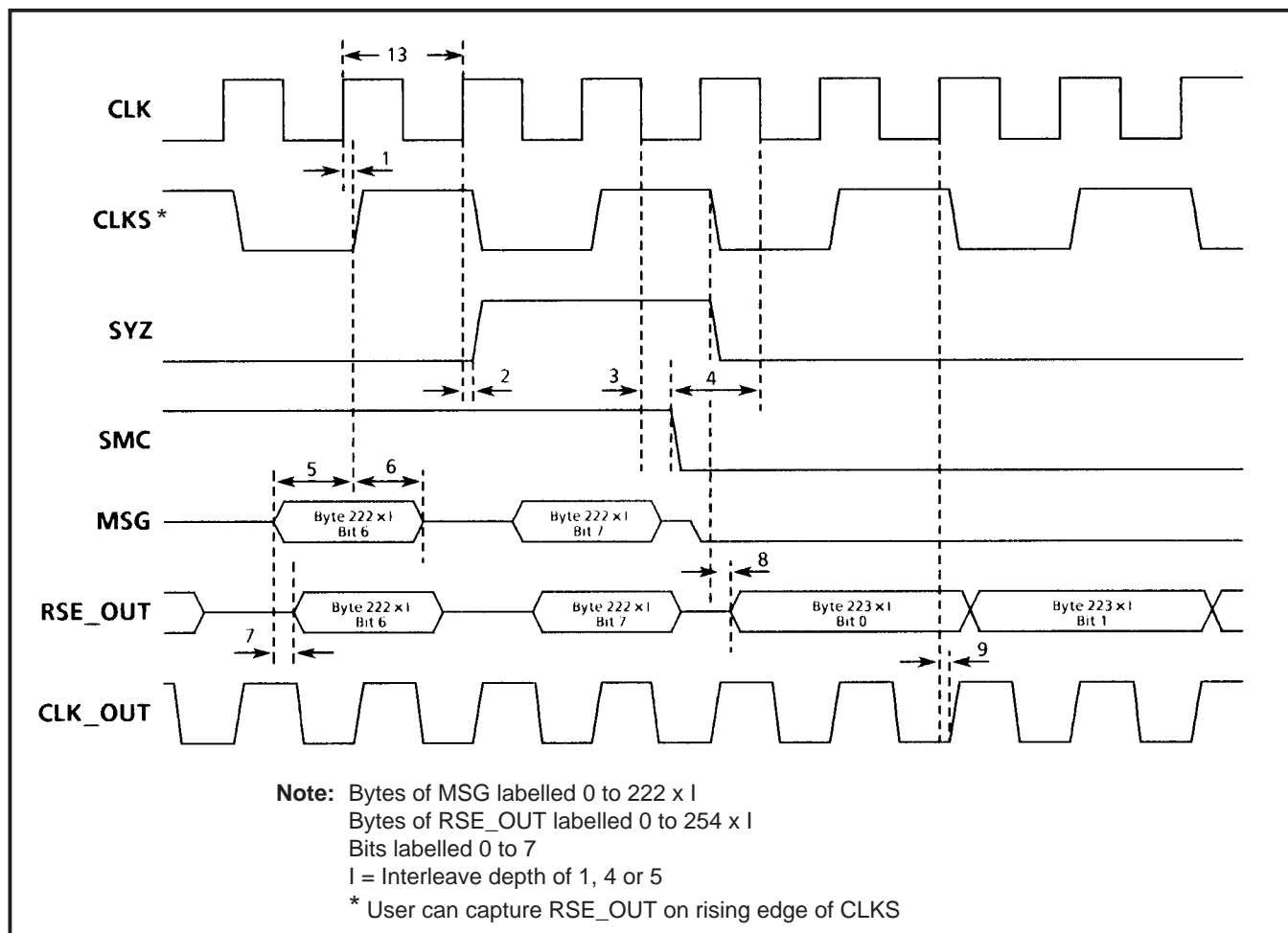

Figure 6: RS Encoder Timings

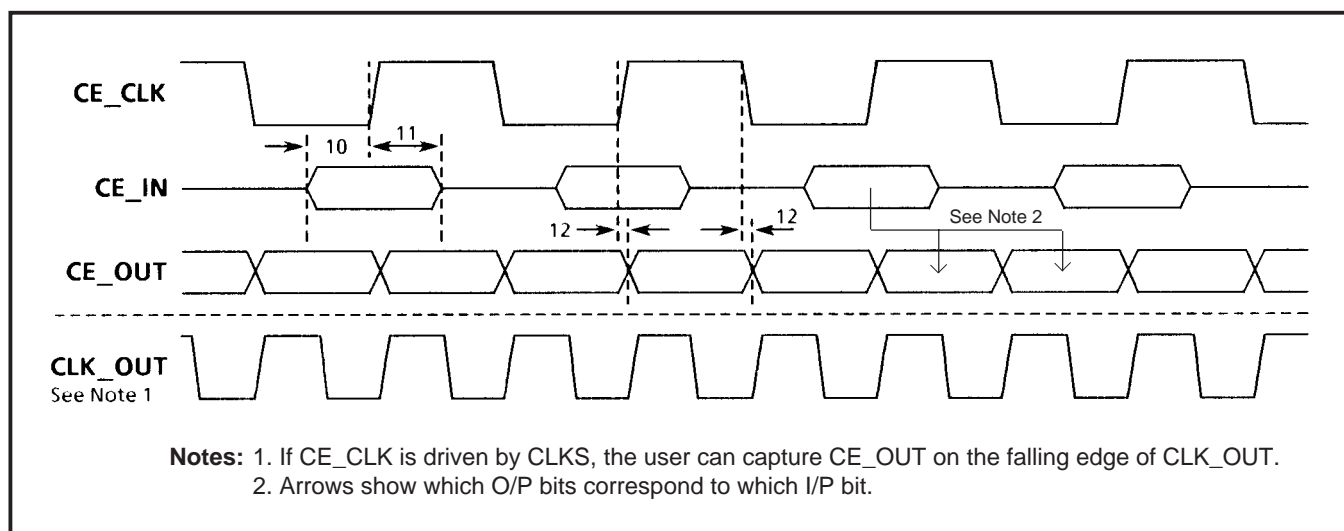

Figure 7: Convolution Encoder Timings

OUTLINES AND PIN ASSIGNMENTS

Ref	Millimetres			Inches		
	Min.	Nom.	Max.	Min.	Nom.	Max.
A	-	-	5.715	-	-	0.225
A1	0.38	-	1.53	0.015	-	0.060
b	0.35	-	0.59	0.014	-	0.023
c	0.20	-	0.36	0.008	-	0.014
D	-	-	36.02	-	-	1.418
e	-	2.54 Typ.	-	-	0.100 Typ.	-
e1	-	15.24 Typ.	-	-	0.600 Typ.	-
H	4.71	-	5.38	0.185	-	0.212
Me	-	-	15.90	-	-	0.626
Z	-	-	1.27	-	-	0.050
W	-	-	1.53	-	-	0.060

XG404

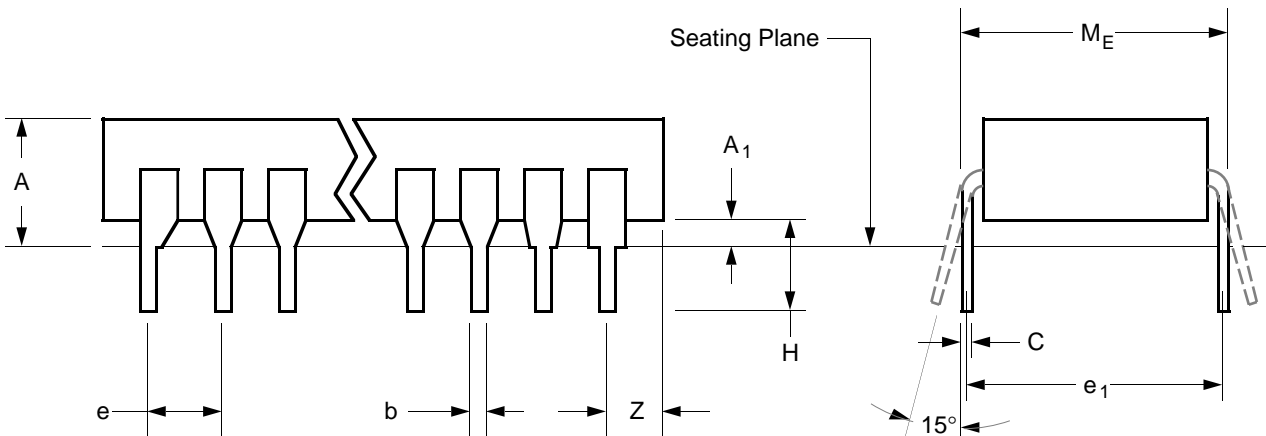
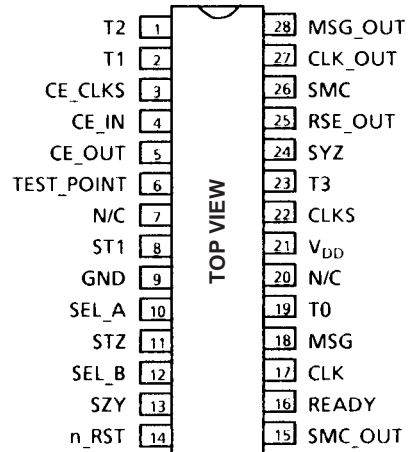
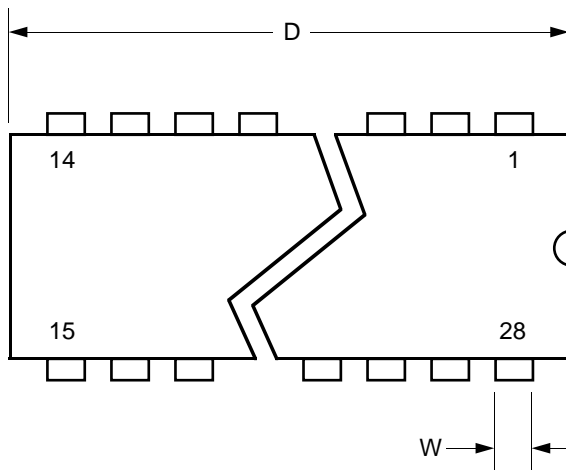

Figure 8: 28-Lead Ceramic DIL (Solder Seal) - Package Style C



Ref	Millimetres			Inches		
	Min.	Nom.	Max.	Min.	Nom.	Max.
A	-	-	3.18	-	-	0.125
Q	0.66	-	-	0.026	-	-
b	0.38	-	0.48	0.015	-	0.019
c	0.10	-	0.18	0.004	-	0.007
D	18.08	-	18.49	0.712	-	0.728
e	-	1.27	-	-	0.050	-
L	7.62	-	9.91	0.300	-	0.390
M	12.50	-	12.09	0.492	-	0.508

XG530

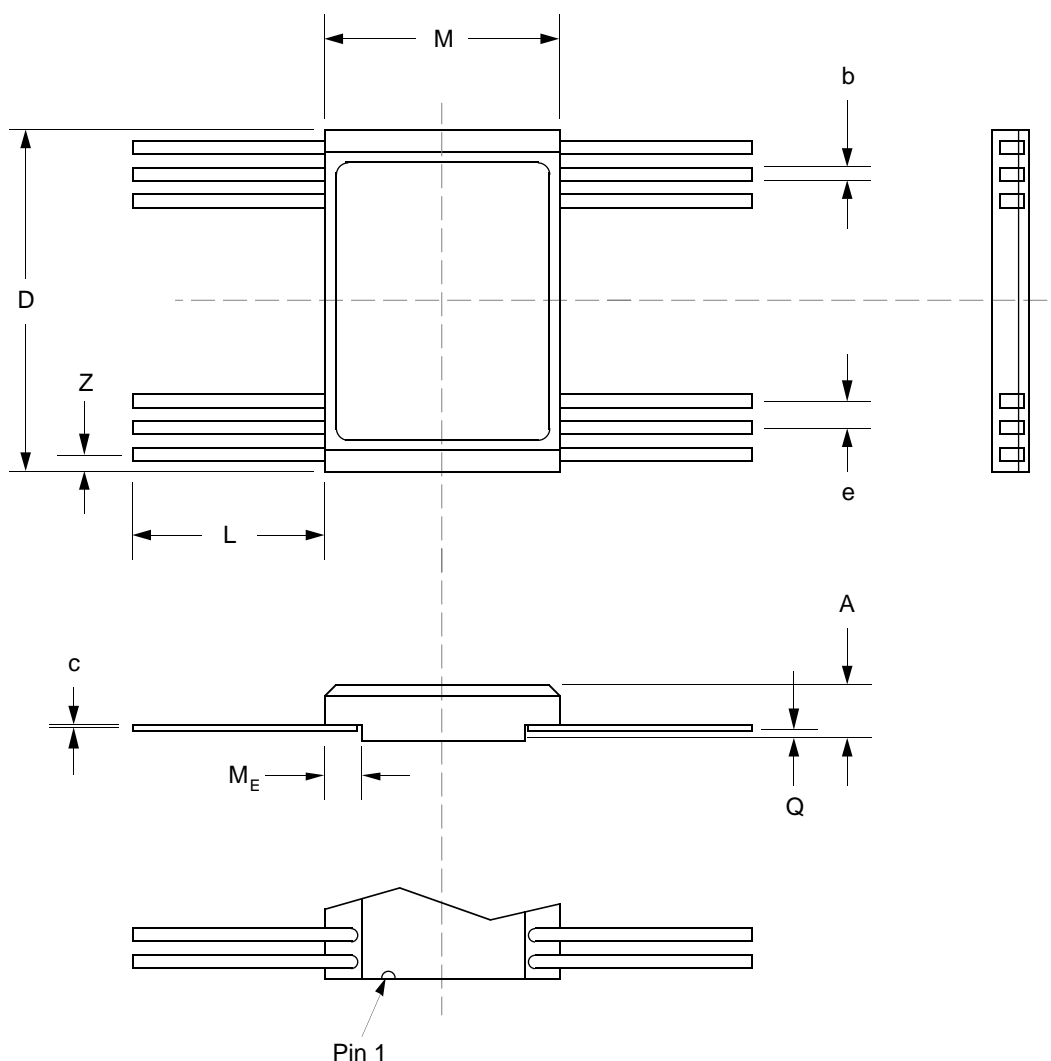

Figure 9: 28-Lead Ceramic Flatpack (Solder Seal) - Package Style F

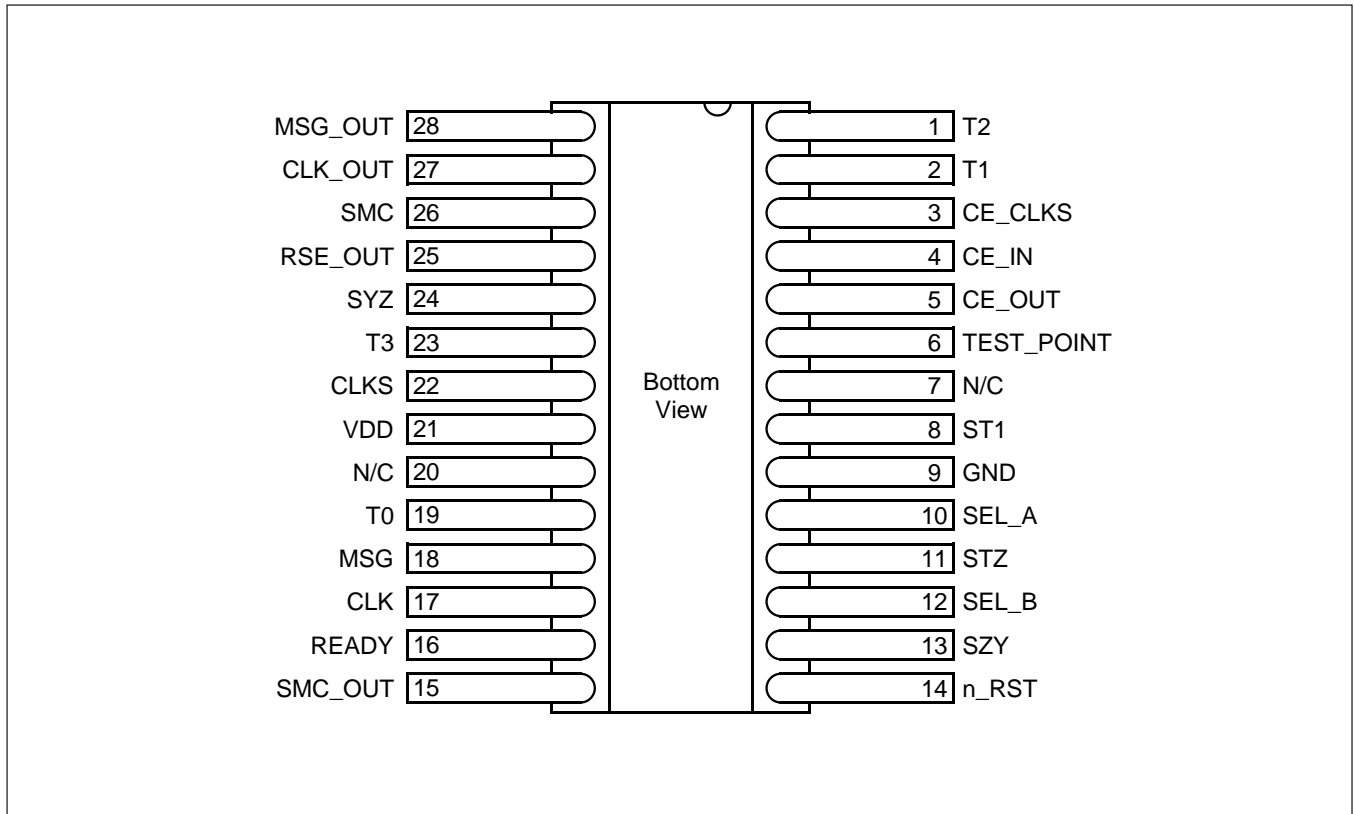

Figure 10: Flatpack Pinout

**RADIATION TOLERANCE**

**Total Dose Radiation Testing**

For product procured to guaranteed total dose radiation levels, each wafer lot will be approved when all sample devices from each lot pass the total dose radiation test.

The sample devices will be subjected to the total dose radiation level (Cobalt-60 Source), defined by the ordering code, and must continue to meet the electrical parameters specified in the data sheet. Electrical tests, pre and post irradiation, will be read and recorded.

Dynex Semiconductor can provide radiation testing compliant with Mil-Std-883 test method 1019, Ionizing Radiation (Total Dose).

Total Dose (Function to specification)*	1x10 <sup>5</sup> Rad(Si)
Transient Upset (Stored data loss)	5x10 <sup>10</sup> Rad(Si)/sec
Transient Upset (Survivability)	>1x10 <sup>12</sup> Rad(Si)/sec
Neutron Hardness (Function to specification)	>1x10 <sup>15</sup> n/cm <sup>2</sup>
Single Event Upset**	<1x10 <sup>-10</sup> Errors/bit day
Latch Up	Not possible

\* Other total dose radiation levels available on request

\*\* Worst case galactic cosmic ray upset - interplanetary/high altitude orbit

**Table 9: Radiation Hardness Parameters**

## ORDERING INFORMATION

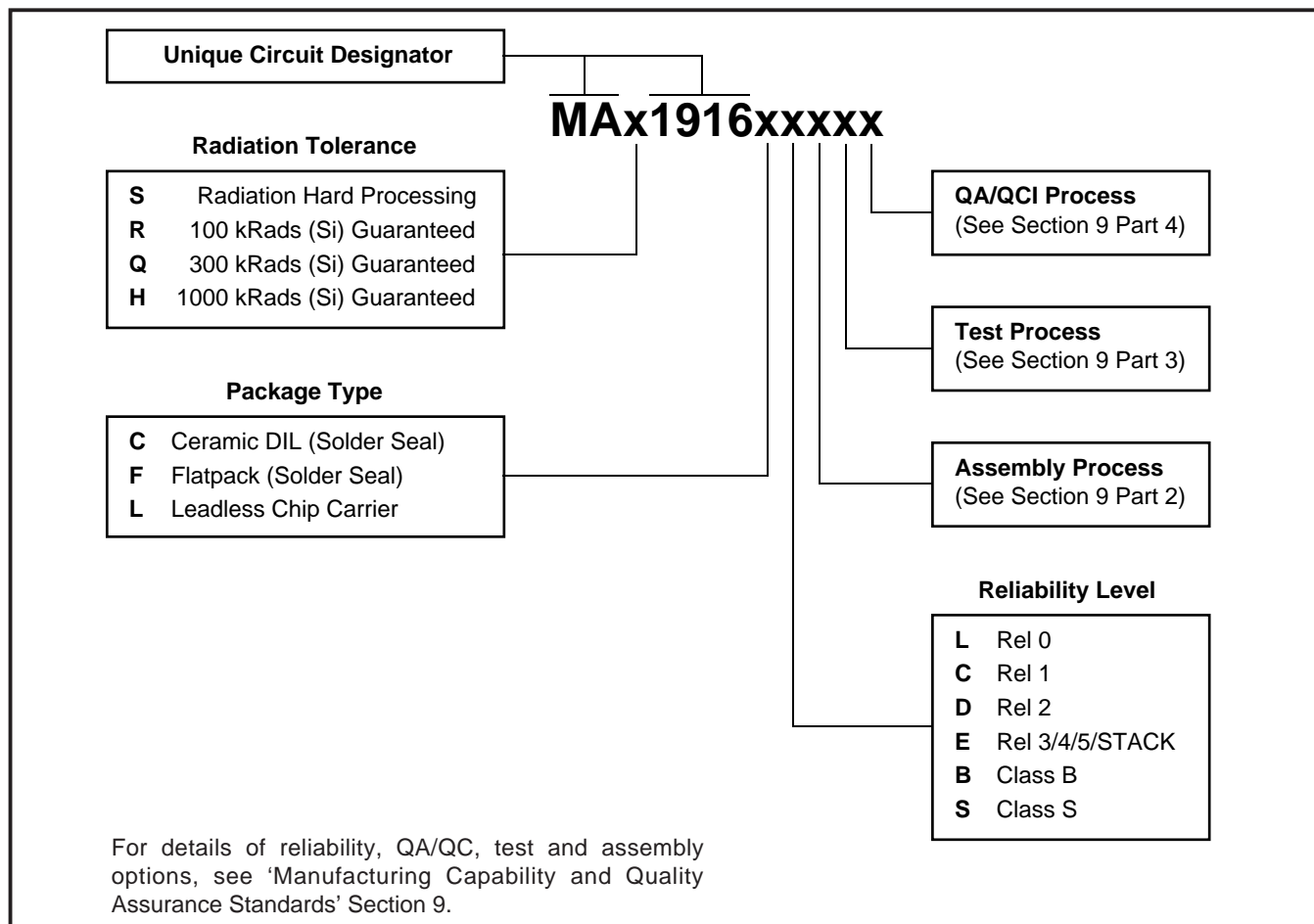

<http://www.dynexsemi.com>

e-mail: [power\\_solutions@dynexsemi.com](mailto:power_solutions@dynexsemi.com)

**HEADQUARTERS OPERATIONS**  
**DYNEX SEMICONDUCTOR LTD**  
 Doddington Road, Lincoln.  
 Lincolnshire. LN6 3LF. United Kingdom.  
 Tel: 00-44-(0)1522-500500  
 Fax: 00-44-(0)1522-500550

**DYNEX POWER INC.**  
 Unit 7 - 58 Antares Drive,  
 Nepean, Ontario, Canada K2E 7W6.  
 Tel: 613.723.7035  
 Fax: 613.723.1518  
 Toll Free: 1.888.33.DYNEX (39639)

**CUSTOMER SERVICE CENTRES**  
**France, Benelux, Italy and Spain** Tel: +33 (0)1 69 18 90 00. Fax: +33 (0)1 64 46 54 50  
**North America** Tel: 011-800-5554-5554. Fax: 011-800-5444-5444  
**UK, Germany, Scandinavia & Rest Of World** Tel: +44 (0)1522 500500. Fax: +44 (0)1522 500020

**SALES OFFICES**  
**France, Benelux, Italy and Spain** Tel: +33 (0)1 69 18 90 00. Fax: +33 (0)1 64 46 54 50  
**Germany** Tel: 07351 827723  
**North America** Tel: (613) 723-7035. Fax: (613) 723-1518. Toll Free: 1.888.33.DYNEX (39639) /  
 Tel: (831) 440-1988. Fax: (831) 440-1989 / Tel: (949) 733-3005. Fax: (949) 733-2986.  
**UK, Germany, Scandinavia & Rest Of World** Tel: +44 (0)1522 500500. Fax: +44 (0)1522 500020  
 These offices are supported by Representatives and Distributors in many countries world-wide.  
 © Dynex Semiconductor 2000 Publication No. DS3590-5 Issue No. 5.0 January 2000  
 TECHNICAL DOCUMENTATION – NOT FOR RESALE. PRINTED IN UNITED KINGDOM

**Datasheet Annotations:**

Dynex Semiconductor annotate datasheets in the top right hand corner of the front page, to indicate product status. The annotations are as follows:-

**Target Information:** This is the most tentative form of information and represents a very preliminary specification. No actual design work on the product has been started.

**Preliminary Information:** The product is in design and development. The datasheet represents the product as it is understood but details may change.

**Advance Information:** The product design is complete and final characterisation for volume production is well in hand.

**No Annotation:** The product parameters are fixed and the product is available to datasheet specification.

This publication is issued to provide information only which (unless agreed by the Company in writing) may not be used, applied or reproduced for any purpose nor form part of any order or contract nor to be regarded as a representation relating to the products or services concerned. No warranty or guarantee express or implied is made regarding the capability, performance or suitability of any product or service. The Company reserves the right to alter without prior notice the specification, design or price of any product or service. Information concerning possible methods of use is provided as a guide only and does not constitute any guarantee that such methods of use will be satisfactory in a specific piece of equipment. It is the user's responsibility to fully determine the performance and suitability of any equipment using such information and to ensure that any publication or data used is up to date and has not been superseded. These products are not suitable for use in any medical products whose failure to perform may result in significant injury or death to the user. All products and materials are sold and services provided subject to the Company's conditions of sale, which are available on request.

All brand names and product names used in this publication are trademarks, registered trademarks or trade names of their respective owners.