

FEATURES

- Double Side Cooling
- High Surge Capability

APPLICATIONS

- Rectification
- Freewheel Diode
- DC Motor Control
- Power Supplies
- Welding
- Battery Chargers

VOLTAGE RATINGS

Type Number	Repetitive Peak Reverse Voltage V_{RRM} V	Conditions
DS2009SF48	4800	$V_{RSM} = V_{RRM} + 100V$
DS2009SF47	4700	
DS2009SF46	4600	
DS2009SF45	4500	
DS2009SF44	4400	
DS2009SF43	4300	

Lower voltage grades available.

ORDERING INFORMATION

When ordering, select the required part number shown in the Voltage Ratings selection table, e.g.:

DS2009SF47

Note: Please use the complete part number when ordering and quote this number in any future correspondence relating to your order.

KEY PARAMETERS

V_{RRM} 4800V

$I_{F(AV)}$ 1428A

I_{FSM} 20500A

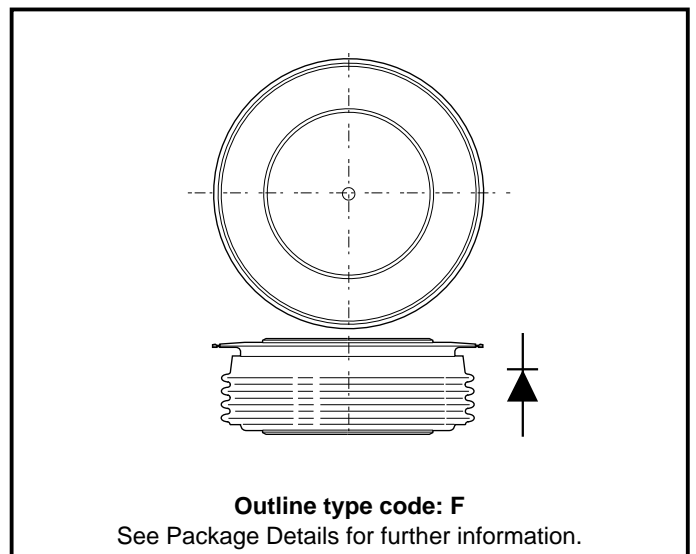

Fig. 1 Package outline

CURRENT RATINGS

$T_{case} = 75^{\circ}\text{C}$ unless otherwise stated

Symbol	Parameter	Conditions	Max.	Units
Double Side Cooled				
$I_{F(AV)}$	Mean forward current	Half wave resistive load	1428	A
$I_{F(RMS)}$	RMS value	-	2242	A
I_F	Continuous (direct) forward current	-	2082	A
Single Side Cooled (Anode side)				
$I_{F(AV)}$	Mean forward current	Half wave resistive load	1033	A
$I_{F(RMS)}$	RMS value	-	1622	A
I_F	Continuous (direct) forward current	-	1424	A

$T_{case} = 100^{\circ}\text{C}$ unless otherwise stated

Symbol	Parameter	Conditions	Max.	Units
Double Side Cooled				
$I_{F(AV)}$	Mean forward current	Half wave resistive load	1105	A
$I_{F(RMS)}$	RMS value	-	1735	A
I_F	Continuous (direct) forward current	-	1580	A
Single Side Cooled (Anode side)				
$I_{F(AV)}$	Mean forward current	Half wave resistive load	730	A
$I_{F(RMS)}$	RMS value	-	1145	A
I_F	Continuous (direct) forward current	-	960	A

SURGE RATINGS

Symbol	Parameter	Conditions	Max.	Units
I_{FSM}	Surge (non-repetitive) forward current	10ms half sine; $T_{case} = 150^{\circ}C$ $V_R = 50\% V_{RRM} - 1/4$ sine	16.5	kA
I^2t	I^2t for fusing		1.35×10^6	A ² s
I_{FSM}	Surge (non-repetitive) forward current	10ms half sine; $T_{case} = 150^{\circ}C$ $V_R = 0$	20.5	kA
I^2t	I^2t for fusing		2.125×10^6	A ² s

THERMAL AND MECHANICAL DATA

Symbol	Parameter	Conditions		Min.	Max.	Units	
$R_{th(j-c)}$	Thermal resistance - junction to case	Double side cooled	dc	-	0.022	$^{\circ}C/W$	
		Single side cooled	Anode dc	-	0.038	$^{\circ}C/W$	
			Cathode dc	-	0.052	$^{\circ}C/W$	
$R_{th(c-h)}$	Thermal resistance - case to heatsink	Clamping force 19.5kN with mounting compound		Double side	-	0.004	$^{\circ}C/W$
				Single side	-	0.008	$^{\circ}C/W$
T_{vj}	Virtual junction temperature	Forward (conducting)		-	160	$^{\circ}C$	
		Reverse (blocking)		-	150	$^{\circ}C$	
T_{stg}	Storage temperature range			-55	175	$^{\circ}C$	
-	Clamping force			18.0	22.0	kN	

CHARACTERISTICS

Symbol	Parameter	Conditions	Min.	Max.	Units
V_{FM}	Forward voltage	At 3400A peak, $T_{case} = 25^{\circ}C$	-	1.8	V
I_{RRM}	Peak reverse current	At V_{RRM} , $T_{case} = 150^{\circ}C$	-	75	mA
Q_S	Total stored charge	$I_F = 2000A$, $di_{RR}/dt = 3A/\mu s$, $T_{case} = 150^{\circ}C$, $V_R = 100V$	-	4000	μC
I_{RM}	Peak recovery current		-	115	A
V_{TO}	Threshold voltage	At $T_{vj} = 150^{\circ}C$	-	0.84	V
r_T	Slope resistance	At $T_{vj} = 150^{\circ}C$	-	0.383	m Ω

CURVES

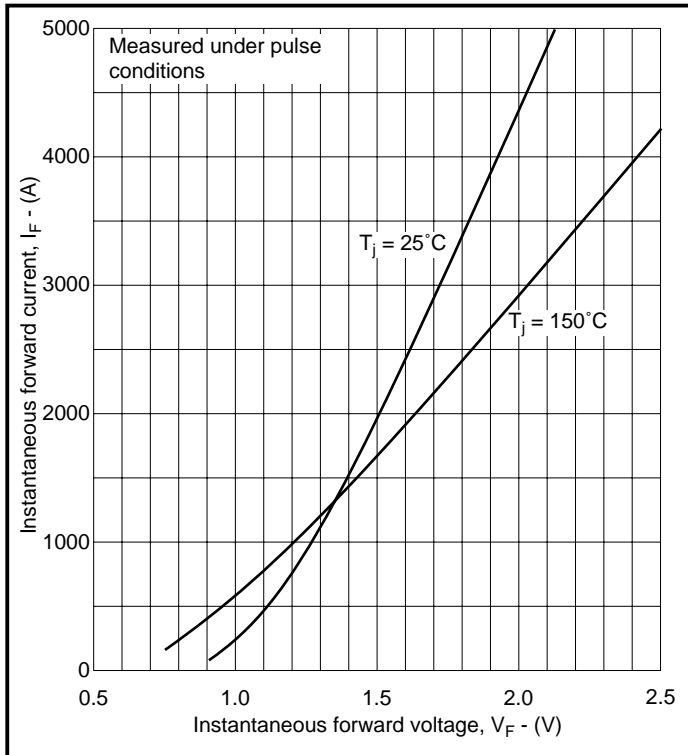

Fig.2 Maximum (limit) forward characteristics

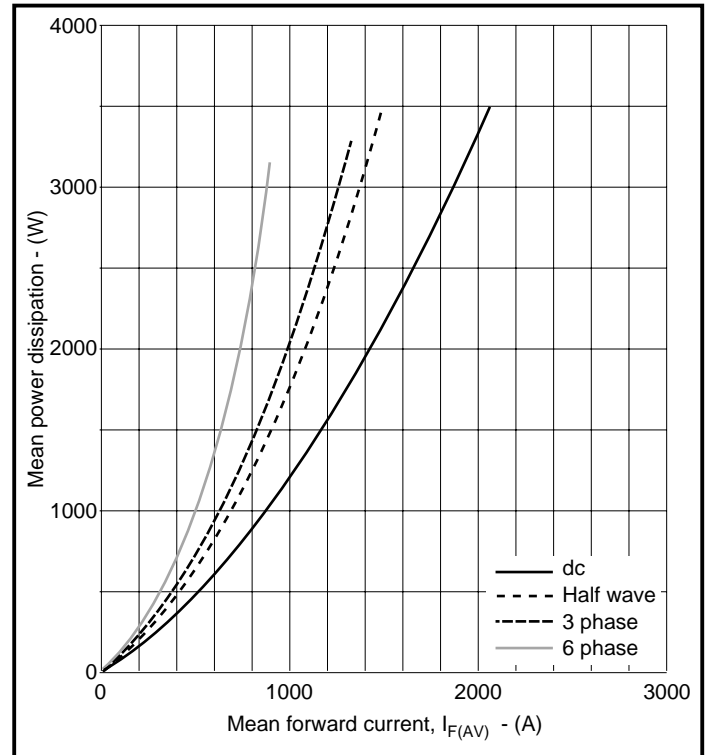

Fig.3 Dissipation curves

V_{FM} Equation:-

$$V_{FM} = A + B \ln(I_F) + C \cdot I_F + D \cdot \sqrt{I_F}$$

Where

A = 0.290476

B = 0.06449

C = 0.000335

D = 0.00408

these values are valid for $T_j = 125^{\circ}C$ for I_F 500A to 5000A

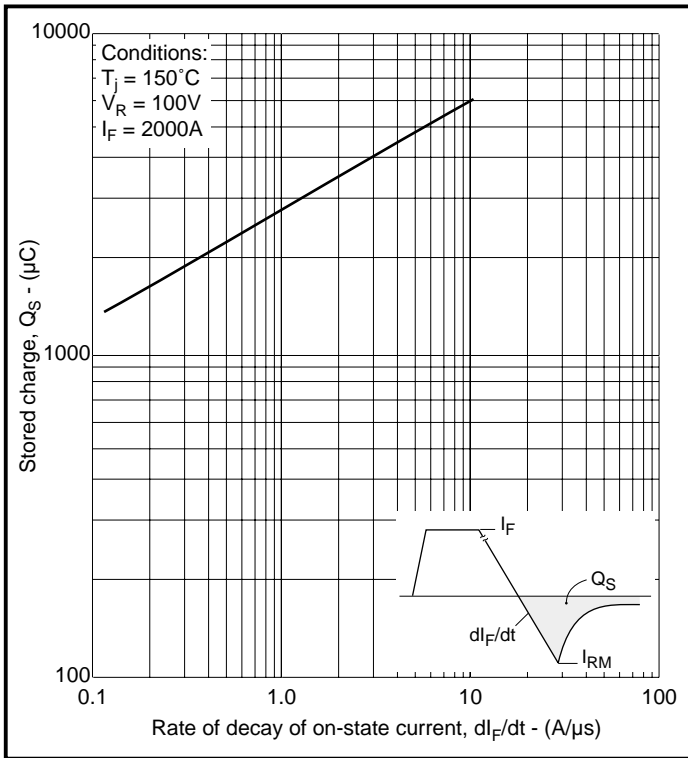

Fig.4 Total stored charge

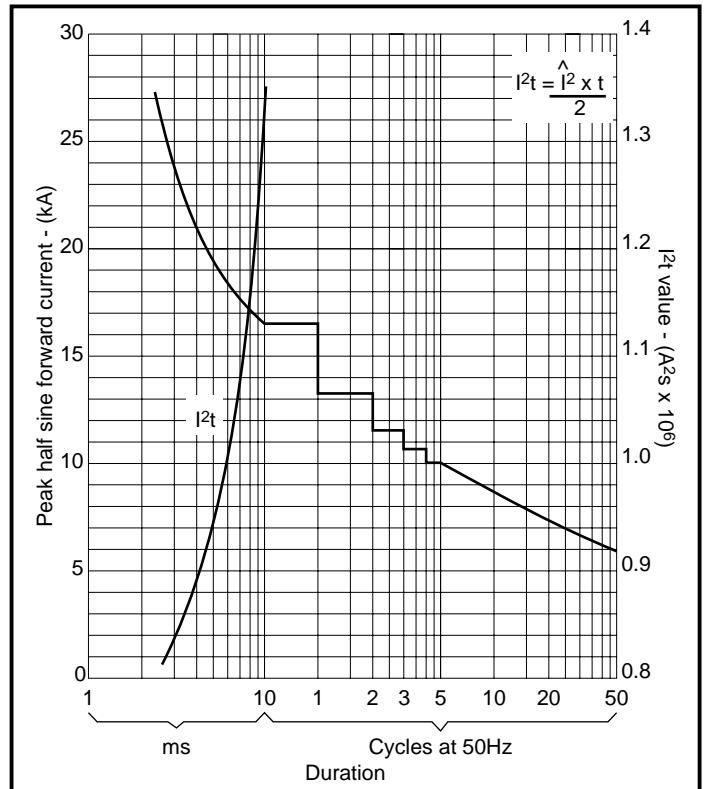

Fig.5 Surge (non-repetitive) forward current vs time (with 50% V_{RRM} at $T_{case} 150^\circ\text{C}$)

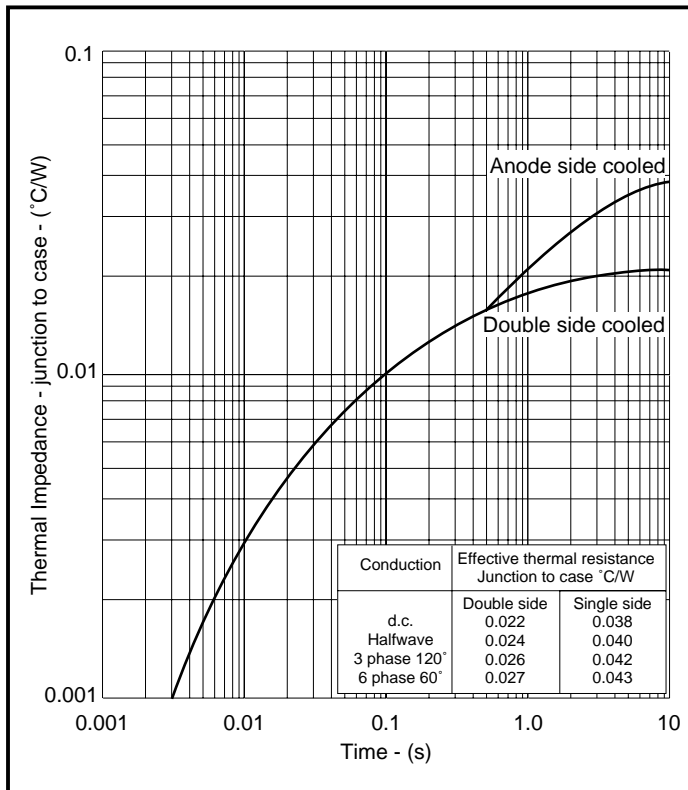
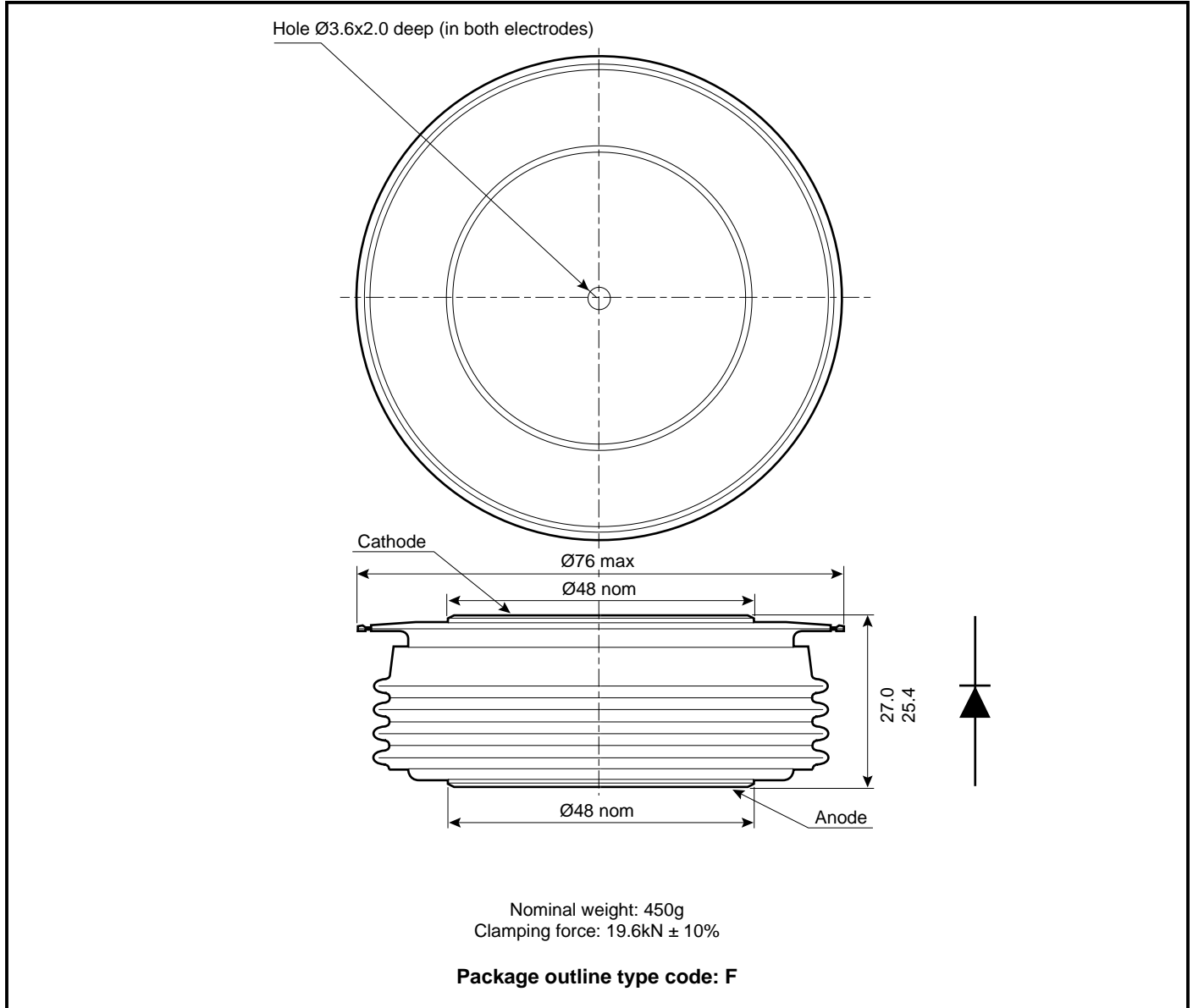

Fig.6 Maximum (limit) transient thermal impedance - junction to case

PACKAGE DETAILS

For further package information, please contact your nearest Customer Service Centre. All dimensions in mm, unless stated otherwise. DO NOT SCALE.



Note:
1. Package may be supplied with pins and/or tags.

POWER ASSEMBLY CAPABILITY

The Power Assembly group was set up to provide a support service for those customers requiring more than the basic semiconductor, and has developed a flexible range of heatsink / clamping systems in line with advances in device types and the voltage and current capability of our semiconductors.

We offer an extensive range of air and liquid cooled assemblies covering the full range of circuit designs in general use today. The Assembly group continues to offer high quality engineering support dedicated to designing new units to satisfy the growing needs of our customers.

Using the up to date CAD methods our team of design and applications engineers aim to provide the Power Assembly Complete solution (PACs).

DEVICE CLAMPS

Disc devices require the correct clamping force to ensure their safe operation. The PACs range offers a varied selection of pre-loaded clamps to suit all of our manufactured devices. This include cube clamps for single side cooling of 'T' 22mm

Clamps are available for single or double side cooling, with high insulation versions for high voltage assemblies.

Please refer to our application note on device clamping, AN4839

HEATSINKS

Power Assembly has its own proprietary range of extruded aluminium heatsinks. They have been designed to optimise the performance of our semiconductors. Data with respect to air natural, forced air and liquid cooling (with flow rates) is available on request.

For further information on device clamps, heatsinks and assemblies, please contact your nearest Sales Representative or Customer Services.



<http://www.dynexsemi.com>

e-mail: power_solutions@dynexsemi.com

HEADQUARTERS OPERATIONS
DYNEX SEMICONDUCTOR LTD
Doddington Road, Lincoln.
Lincolnshire. LN6 3LF. United Kingdom.
Tel: 00-44-(0)1522-500500
Fax: 00-44-(0)1522-500550

DYNEX POWER INC.
99 Bank Street, Suite 410,
Ottawa, Ontario, Canada, K1P 6B9
Tel: 613.723.7035
Fax: 613.723.1518
Toll Free: 1.888.33.DYNEX (39639)

CUSTOMER SERVICE CENTRES
Mainland Europe Tel: +33 (0)1 58 04 91 00. Fax: +33 (0)1 46 38 51 33
North America Tel: (613) 723-7035. Fax: (613) 723-1518.
UK, Scandinavia & Rest Of World Tel: +44 (0)1522 500500. Fax: +44 (0)1522 500020

SALES OFFICES
Mainland Europe Tel: +33 (0)1 58 04 91 00. Fax: +33 (0)1 46 38 51 33
North America Tel: (613) 723-7035. Fax: (613) 723-1518. Toll Free: 1.888.33.DYNEX (39639) /
Tel: (949) 733-3005. Fax: (949) 733-2986.
UK, Scandinavia & Rest Of World Tel: +44 (0)1522 500500. Fax: +44 (0)1522 500020

These offices are supported by Representatives and Distributors in many countries world-wide.
© Dynex Semiconductor 2001 Publication No. DS4190-4 Issue No. 4.1 December 2001
TECHNICAL DOCUMENTATION – NOT FOR RESALE. PRINTED IN UNITED KINGDOM

Datasheet Annotations:

Dynex Semiconductor annotate datasheets in the top right hand corner of the front page, to indicate product status. The annotations are as follows:-

Target Information: This is the most tentative form of information and represents a very preliminary specification. No actual design work on the product has been started.

Preliminary Information: The product is in design and development. The datasheet represents the product as it is understood but details may change.

Advance Information: The product design is complete and final characterisation for volume production is well in hand.

No Annotation: The product parameters are fixed and the product is available to datasheet specification.

This publication is issued to provide information only which (unless agreed by the Company in writing) may not be used, applied or reproduced for any purpose nor form part of any order or contract nor to be regarded as a representation relating to the products or services concerned. No warranty or guarantee express or implied is made regarding the capability, performance or suitability of any product or service. The Company reserves the right to alter without prior notice the specification, design or price of any product or service. Information concerning possible methods of use is provided as a guide only and does not constitute any guarantee that such methods of use will be satisfactory in a specific piece of equipment. It is the user's responsibility to fully determine the performance and suitability of any equipment using such information and to ensure that any publication or data used is up to date and has not been superseded. These products are not suitable for use in any medical products whose failure to perform may result in significant injury or death to the user. All products and materials are sold and services provided subject to the Company's conditions of sale, which are available on request.

All brand names and product names used in this publication are trademarks, registered trademarks or trade names of their respective owners.