

This datasheet should be used in conjunction with the application note AN4571, GDU9X-XXXXX Series, Gate Drive Unit.

### APPLICATIONS

- Used with Gate Turn-Off Thyristors in high current switching applications

### KEY PARAMETERS

$I_{FGM}$	40A
$I_{G(ON)}$	8A
$di_{GQ}/dt$	40A/ $\mu$ s

### CONDITIONS - (UNLESS STATED OTHERWISE)

$V_1 = +5V$	$V_2 = +15V$	$V_3 = -15V$
Test circuit GTO	DG758BX	
GDU connection to GTO	500mm CO - AX cable type RC5327230	
Test circuit emitter and gate drive emitter	Hewlett Packard versatile link HFBR 1524	
Test circuit emitter current	30mA	
Test circuit receiver and gate drive receiver	Hewlett Packard versatile link HFBR 2524	

### ELECTRICAL CHARACTERISTICS

Symbol	Parameter	Conditions	Min.	Typ.	Max.	Units
$I_{V1}$	+5V PSU current	500Hz, 50% duty cycle	-	-	4.40	A
$I_{V2}$	+15V PSU current	500Hz	-	-	0.48	A
$I_{V3}$	-15V PSU current	500Hz, $I_T = 3000A$ GTO $T_j = 125^\circ C$	-	-	10.0	A
$V_{1(Min)}$	+5V PSU minimum	-	3.8	-	-	V
$V_{2(Min)}$	+15V PSU minimum	-	14.0	-	-	V
$V_{3(Min)}$	-15V PSU minimum	-	14.0	-	-	V
$I_{FGM}$	Peak forward gate current	-	40	-	-	A
$I_{G(ON)}$	On-state gate current	-	-	8	-	A
$di_{FG}/dt$	Rate of rise of positive gate current	Measured 10 - 75% $I_{FGM}$	-	40	-	A/ $\mu$ s
$di_{GQ}/dt$	Rate of rise of negative gate current	$I_T = 3000A$ , 90% $I_{G(ON)}$ - 50% $I_{GQM}$	-	40	-	A/ $\mu$ s

**TIMING CHARACTERISTICS**

Symbol	Parameter	Conditions	Min.	Typ.	Max.	Units
$t_1^{*\dagger}$	No response pulse width of input signal	Adjustable by R81 + R82	2	-	3	$\mu\text{s}$
$t_2$	Delay time emitter current to receiver o/p	-	0.2	-	0.4	$\mu\text{s}$
$t_3^{*\dagger}$	Turn-on delay emitter current to 10% $I_{FGM}$	-	5.0	-	5.8	$\mu\text{s}$
$t_4$	$I_{FGM}$ pulse width	-	-	16	-	$\mu\text{s}$
$t_5^*$	Minimum on time 10% $I_{FGM}$ to 90% $I_{G(ON)}$	Adjustable by R37	80	-	110	$\mu\text{s}$
$t_6$	Receiver storage time	-	0.8	-	1.2	$\mu\text{s}$
$t_7$	Turn-off delay. Emitter current to 90% $I_{G(ON)}$	-	1.5	-	2.3	$\mu\text{s}$
$t_8^*$	Minimum off time 90% $I_{G(ON)}$ to 10% $I_{FGM}$	Adjustable by R38	80	-	110	$\mu\text{s}$
$t_9$	Delay time Gate volts to o/p emitter current	-	-	0.2	-	$\mu\text{s}$
$t_{10}$	Turn-off delay Gate volts to test receiver o/p	-	-	0.8	-	$\mu\text{s}$
$t_{11}$	Storage time Gate volts to o/p emitter current	Measured at low $I_{GQM}$	-	0.1 <sup>1</sup>	-	$\mu\text{s}$
$t_{12}$	Turn-on delay Gate volts to test receiver o/p	Measured at low $I_{GQM}$	-	0.3 <sup>1</sup>	-	$\mu\text{s}$

\*  $t_1, t_3, t_5, t_8$  are factory settings.

<sup>†</sup> Adjustment of  $t_1$  alters  $t_3$

1. Varies with  $I_{GQM}$  due to gate lead impedance.

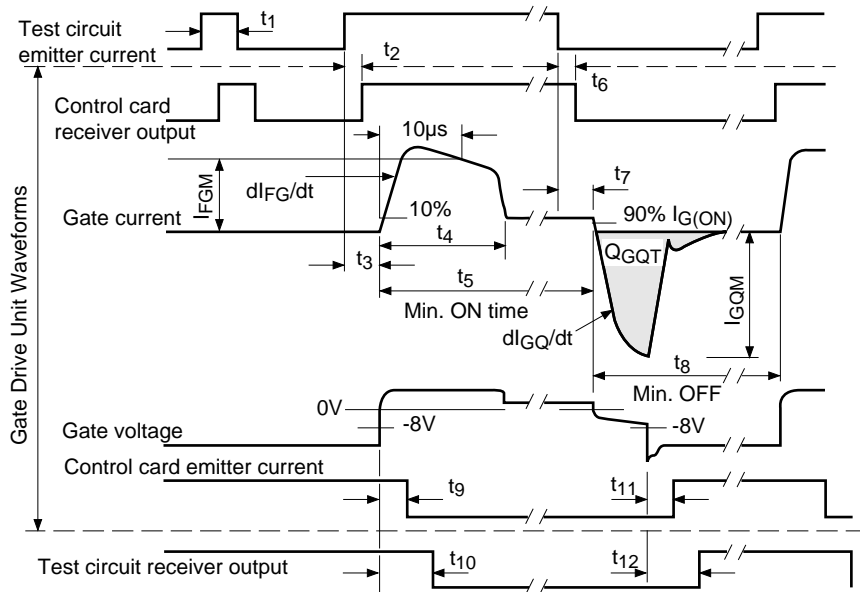

OUTLINE

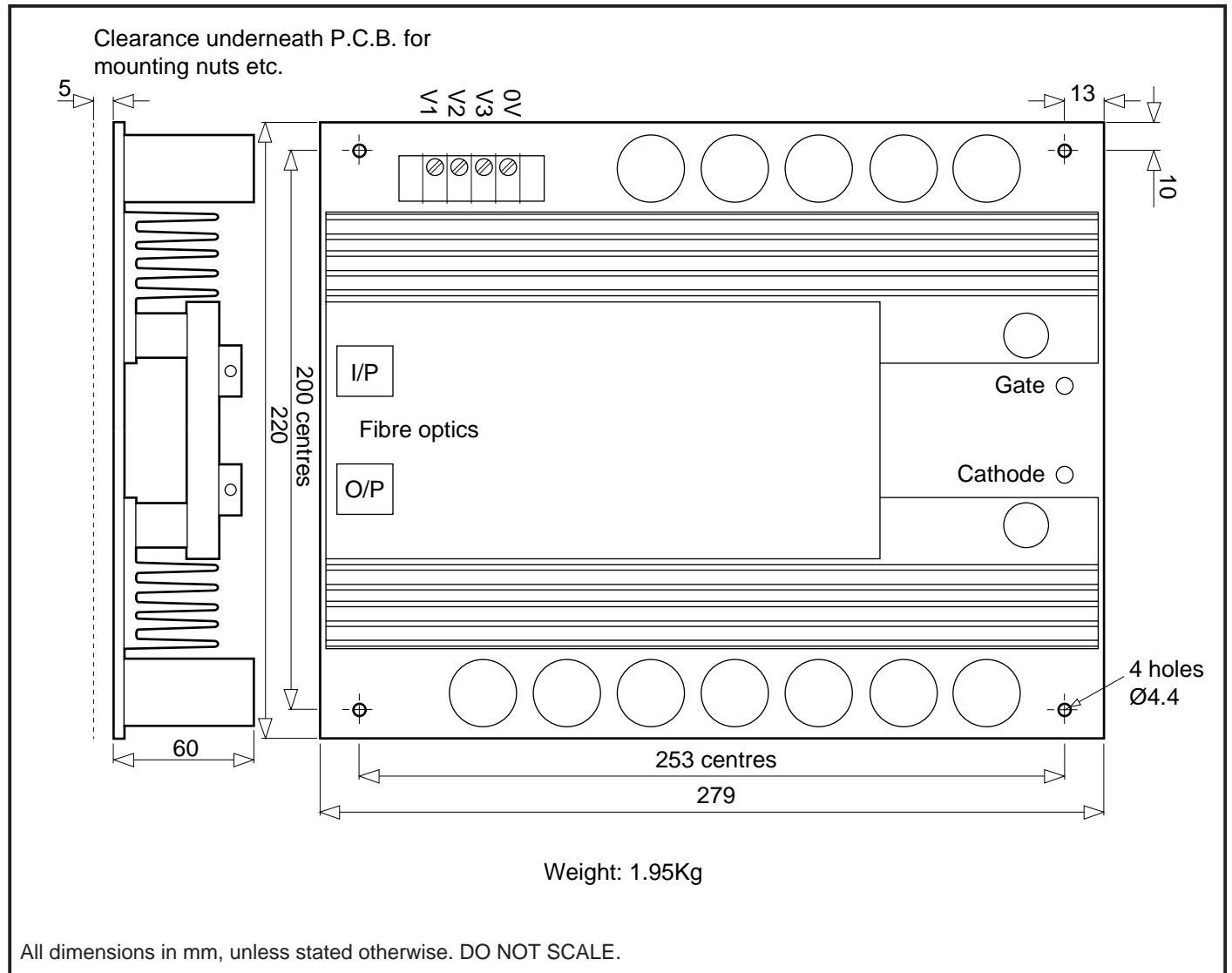

## POWER ASSEMBLY CAPABILITY

The Power Assembly group was set up to provide a support service for those customers requiring more than the basic semiconductor, and has developed a flexible range of heatsink / clamping systems in line with advances in device types and the voltage and current capability of our semiconductors.

We offer an extensive range of air and liquid cooled assemblies covering the full range of circuit designs in general use today. The Assembly group continues to offer high quality engineering support dedicated to designing new units to satisfy the growing needs of our customers.

Using the up to date CAD methods our team of design and applications engineers aim to provide the Power Assembly Complete solution (PACs).

## DEVICE CLAMPS

Disc devices require the correct clamping force to ensure their safe operation. The PACs range offers a varied selection of pre-loaded clamps to suit all of our manufactured devices. This include cube clamps for single side cooling of 'T' 22mm

Clamps are available for single or double side cooling, with high insulation versions for high voltage assemblies.

Please refer to our application note on device clamping, AN4839

## HEATSINKS

Power Assembly has it's own proprietary range of extruded aluminium heatsinks. They have been designed to optimise the performance of our semiconductors. Data with respect to air natural, forced air and liquid cooling (with flow rates) is available on request.

For further information on device clamps, heatsinks and assemblies, please contact your nearest Sales Representative or the factory.



<http://www.dynexsemi.com>

e-mail: [power\\_solutions@dynexsemi.com](mailto:power_solutions@dynexsemi.com)

HEADQUARTERS OPERATIONS  
**DYNEX SEMICONDUCTOR LTD**  
Doddington Road, Lincoln.  
Lincolnshire. LN6 3LF. United Kingdom.  
Tel: 00-44-(0)1522-500500  
Fax: 00-44-(0)1522-500550

**DYNEX POWER INC.**  
Unit 7 - 58 Antares Drive,  
Nepean, Ontario, Canada K2E 7W6.  
Tel: 613.723.7035  
Fax: 613.723.1518  
Toll Free: 1.888.33.DYNEX (39639)

CUSTOMER SERVICE CENTRES  
**France, Benelux, Italy and Spain** Tel: +33 (0)1 69 18 90 00. Fax: +33 (0)1 64 46 54 50  
**North America** Tel: 011-800-5554-5554. Fax: 011-800-5444-5444  
**UK, Germany, Scandinavia & Rest Of World** Tel: +44 (0)1522 500500. Fax: +44 (0)1522 500020

SALES OFFICES  
**France, Benelux, Italy and Spain** Tel: +33 (0)1 69 18 90 00. Fax: +33 (0)1 64 46 54 50  
**Germany** Tel: 07351 827723  
**North America** Tel: (613) 723-7035. Fax: (613) 723-1518. Toll Free: 1.888.33.DYNEX (39639) /  
Tel: (831) 440-1988. Fax: (831) 440-1989 / Tel: (949) 733-3005. Fax: (949) 733-2986.  
**UK, Germany, Scandinavia & Rest Of World** Tel: +44 (0)1522 500500. Fax: +44 (0)1522 500020  
These offices are supported by Representatives and Distributors in many countries world-wide.  
© Dynex Semiconductor 2000 Publication No. DS4562-5 Issue No. 5.0 January 2000  
TECHNICAL DOCUMENTATION – NOT FOR RESALE. PRINTED IN UNITED KINGDOM

### Datasheet Annotations:

Dynex Semiconductor annotate datasheets in the top right hand corner of the front page, to indicate product status. The annotations are as follows:-

**Target Information:** This is the most tentative form of information and represents a very preliminary specification. No actual design work on the product has been started.

**Preliminary Information:** The product is in design and development. The datasheet represents the product as it is understood but details may change.

**Advance Information:** The product design is complete and final characterisation for volume production is well in hand.

**No Annotation:** The product parameters are fixed and the product is available to datasheet specification.

This publication is issued to provide information only which (unless agreed by the Company in writing) may not be used, applied or reproduced for any purpose nor form part of any order or contract nor to be regarded as a representation relating to the products or services concerned. No warranty or guarantee express or implied is made regarding the capability, performance or suitability of any product or service. The Company reserves the right to alter without prior notice the specification, design or price of any product or service. Information concerning possible methods of use is provided as a guide only and does not constitute any guarantee that such methods of use will be satisfactory in a specific piece of equipment. It is the user's responsibility to fully determine the performance and suitability of any equipment using such information and to ensure that any publication or data used is up to date and has not been superseded. These products are not suitable for use in any medical products whose failure to perform may result in significant injury or death to the user. All products and materials are sold and services provided subject to the Company's conditions of sale, which are available on request.

All brand names and product names used in this publication are trademarks, registered trademarks or trade names of their respective owners.