



Certificate Number: Q10561

Certificate Number: E17276

FR151G - FR157G-STR

GLASS PASSIVATED JUNCTION FAST RECOVERY RECTIFIERS

PRV : 50 - 1000 Volts
I_o : 1.5 Amperes

FEATURES :

- * Glass passivated chip
- * High current capability
- * High reliability
- * Low reverse current
- * Low forward voltage drop
- * Fast switching for high efficiency

MECHANICAL DATA :

- * Case : DO-41 Molded plastic
- * Epoxy : UL94V-O rate flame retardant
- * Lead : Axial lead solderable per MIL-STD-202, Method 208 guaranteed
- * Polarity : Color band denotes cathode end
- * Mounting position : Any
- * Weight : 0.339 gram

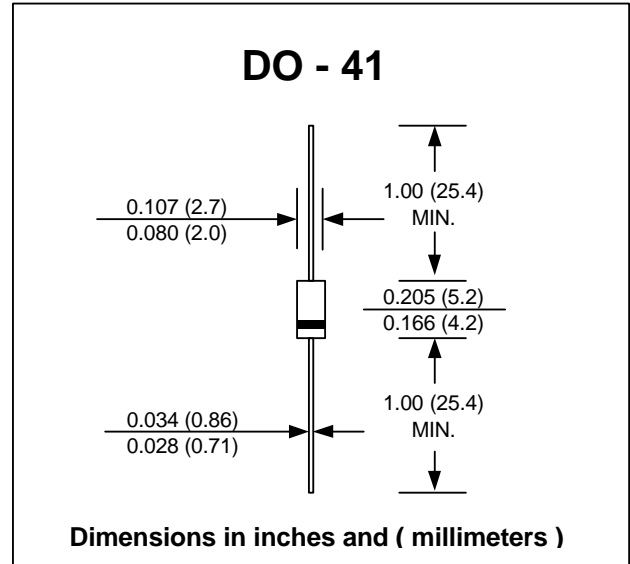

MAXIMUM RATINGS AND ELECTRICAL CHARACTERISTICS

Rating at 25 °C ambient temperature unless otherwise specified.
Single phase, half wave, 60 Hz, resistive or inductive load.
For capacitive load, derate current by 20%.

RATING	SYMBOL	FR151G	FR152G	FR153G	FR154G	FR155G	FR156G	FR157G	FR157G-STR	UNIT
Maximum Recurrent Peak Reverse Voltage	V _{RRM}	50	100	200	400	600	800	1000	1000	Volts
Maximum RMS Voltage	V _{RMS}	35	70	140	280	420	560	700	700	Volts
Maximum DC Blocking Voltage	V _{DC}	50	100	200	400	600	800	1000	1000	Volts
Maximum Average Forward Current 0.375"(9.5mm) Lead Length T _a = 55 °C	I _{F(AV)}	1.5								Amps.
Peak Forward Surge Current, 8.3ms Single half sine wave superimposed on rated load (JEDEC Method)	I _{FSM}	60								Amps.
Maximum Peak Forward Voltage at I _F = 1.5 Amps.	V _F	1.4								Volts
Maximum DC Reverse Current T _a = 25 °C at Rated DC Blocking Voltage T _a = 100 °C	I _R	5.0								μA
	I _{R(H)}	50								μA
Maximum Reverse Recovery Time (Note 1)	T _{rr}	150			250		500		250	ns
Typical Junction Capacitance (Note 2)	C _J	25								pf
Junction Temperature Range	T _J	- 65 to + 150								°C
Storage Temperature Range	T _{STG}	- 65 to + 150								°C

Notes :

- (1) Reverse Recovery Test Conditions : I_F = 0.5 A, I_R = 1.0 A, I_{rr} = 0.25 A.
- (2) Measured at 1.0 MHz and applied reverse voltage of 4.0 V_{bc}

UPDATE : APRIL 23, 1998

RATING AND CHARACTERISTIC CURVES (FR151G - FR157G)

FIG.1 - REVERSE RECOVERY TIME CHARACTERISTIC AND TEST CIRCUIT DIAGRAM

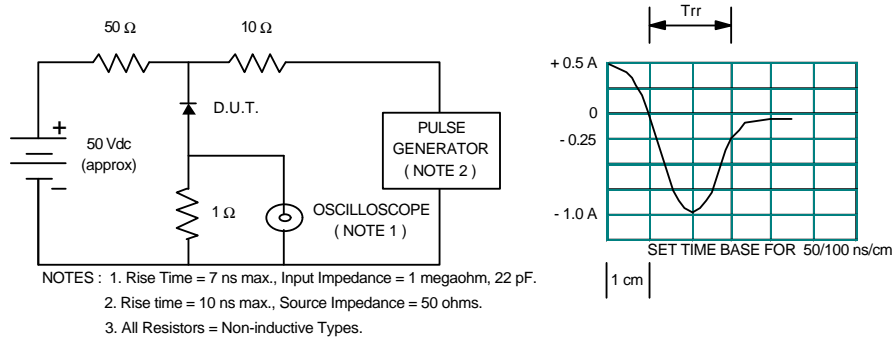

FIG.2 - DERATING CURVE FOR OUTPUT RECTIFIED CURRENT

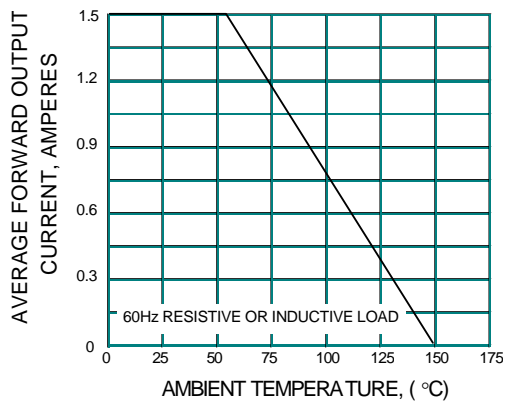

FIG.3 - MAXIMUM NON-REPETITIVE PEAK FORWARD SURGE CURRENT

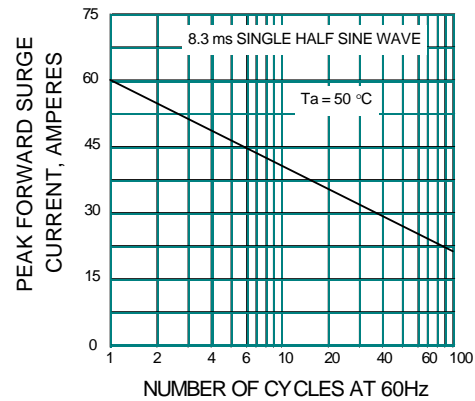

FIG.4 - TYPICAL FORWARD CHARACTERISTICS

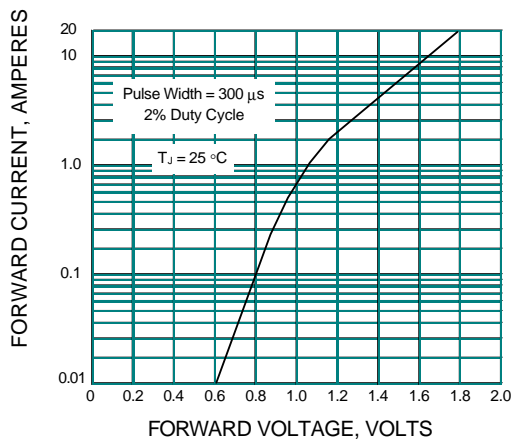

FIG.5 - TYPICAL REVERSE CHARACTERISTICS

