



義隆電子股份有限公司

ELAN MICROELECTRONICS CORP.

EM78804A/803A

8-BIT MICRO-CONTROLLER

Version 1.4

ELAN MICROELECTRONICS CORP.
No. 12, Innovation 1st RD., Science-Based Industrial Park
Hsin Chu City, Taiwan, R.O.C.
TEL: (03) 5639977
FAX: (03)5782037(SL) 5780617 (SA2)



User Application Note

1. ROM, OTP, ICE

| ROM | OTP | ICE |
|---------------|------------|------------|
| EM78804A/803A | EM78P806 | ICE806 |

2. Main Function Difference

| | EM78804A/803A | EM78P806 |
|-------------------|----------------------|-----------------|
| Operation voltage | 2.2 ~ 3.6V | 2.5V ~ 5.5V |



I. General Description

The EM78804A/803A is an 8-bit CID (Call Identification) RISC type microprocessor with low power , high speed CMOS technology . Integrated onto a single chip are on_ chip watchdog (WDT) , RAM , ROM , programmable real time clock /counter , internal interrupt , power down mode , LCD driver , Tone generator and tri-state I/O . EM78804A/803A provides a single chip solution to design a CID of calling message display .

II. Feature

CPU

- **Operating voltage range : 2.2V~3.6V**
- **4Kx 13 on chip ROM (EM78803A)**
8Kx 13 on chip ROM (EM78804A)
- **0.6Kx 8 on chip RAM**
- **Up to 28 bi-directional tri-state I/O ports**
- 8 level stack for subroutine nesting
- 8-bit real time clock/counter (TCC) with 8-bit prescaler
- Two sets of 8 bit counters can be interrupt sources
- Selective signal sources and overflow interrupt
- Programmable free running on chip watchdog timer
- 99.9% single instruction cycle commands
- four modes (Main clock 3.579 , 1.79, 0.895 or 0.447MHz generated by internal PLL)
 1. Sleep mode : CPU and Main clock turn off, 32.768KHz clock turn off
 2. Idle mode : CPU and Main clock turn off, 32.768KHz clock turn on
 3. Green mode : Main clock turn off, CPU and 32.768KHz clock turn on
 4. Normal mode : Main clock turn on , CPU and 32.768KHz clock turn on
- Input port wake up function
- **7 interrupt source , 4 external , 3 internal**
- IO Port key scan function
- IO Port interrupt , pull high ,wake-up and open drain functions
- External Sub-Clock frequency is 32.768KHz
- Dual TONE Generators

LCD

- LCD operation voltage chosen by software
- Common driver pins : 16 (8 of 16 Common shared by I/O)
- Segment driver pins : 32 (12 of 32 Segment shared by I/O)
- 1/4 bias
- 1/8,1/16 duty

PACKAGE

- **64 pin QFP (EM78804AAQ,, POVD disable) (EM78804ABQ, POVD enable) or 64 pin Chip (EM78804AH)**
- **64 pin QFP (EM78803AAQ,, POVD disable) (EM78803ABQ, POVD enable) or 64 pin Chip (EM78803AH)**

III. Application

1. adjunct units
2. answering machines
3. feature phones

IV.Pin Configuration

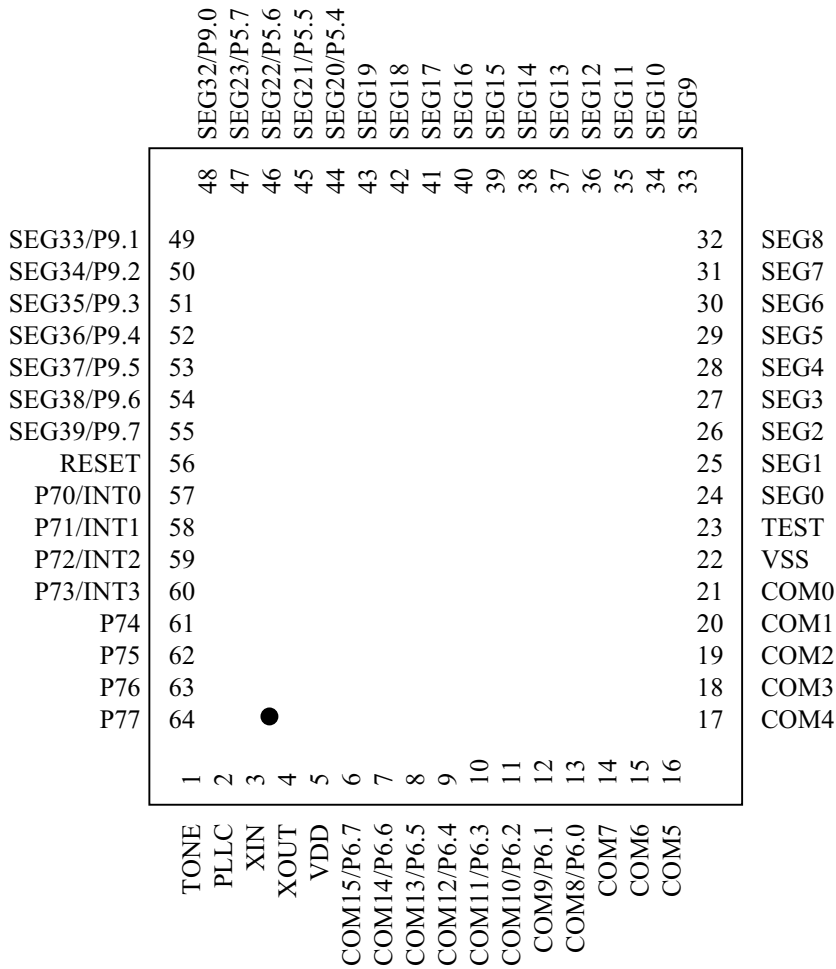

Fig.1 Pin Assignment

V.Functional Block Diagram

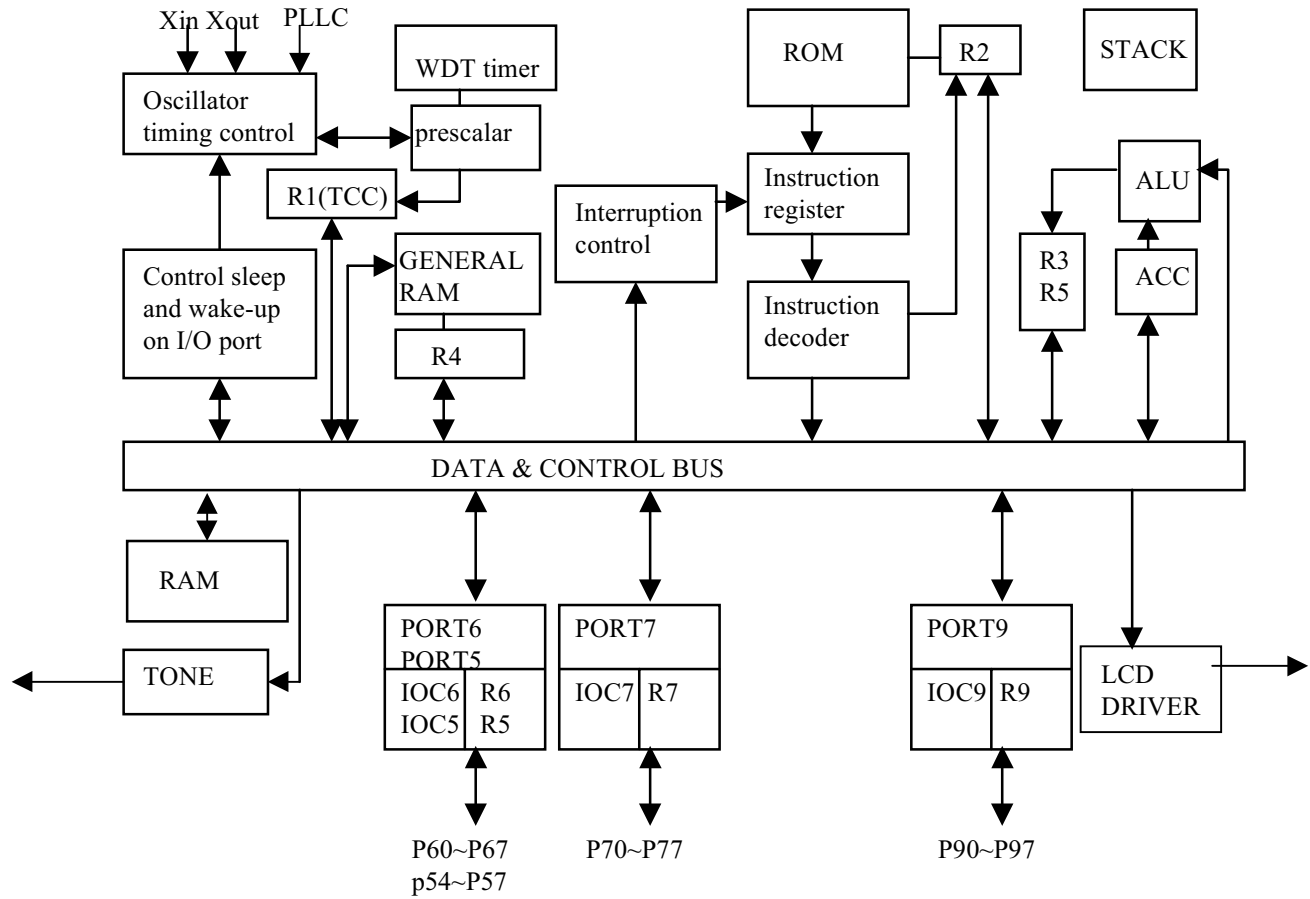

Fig.2 Block diagram

VI.Pin Descriptions

| PIN | I/O | DESCRIPTION |
|--------------|-------------------------------------|---|
| VDD | POWER | digital power |
| AVDD | | analog power |
| VSS | POWER | digital ground |
| AVSS | | analog ground |
| Xtin | I | Input pin for 32.768 kHz oscillator |
| Xtout | O | Output pin for 32.768 kHz oscillator |
| COM0..COM7 | O (PORT6) | Common driver pins of LCD drivers |
| COM8..COM15 | | |
| SEG0...SEG19 | O (PORT5) O (PORT8) O (PORT9) | Segment driver pins of LCD drivers |
| SEG20..SEG23 | | |
| SEG24..SEG31 | | |
| SEG32..SEG39 | | |
| PLL | I | Phase loop lock capacitor, 0.01u to 0.047u with AVSS |
| INT0..INT3 | PORT7(0..3) | PORT7(0)~PORT7(3) signal can be interrupt signals. |
| P5.4 ~P.57 | PORT5 | PORT5 can be INPUT or OUTPUT port each bit. And shared with Segment signal. |
| P7.0 ~P7.7 | PORT7 | PORT7 can be INPUT or OUTPUT port each bit. Internal Pull high function. Key scan function. Bit6,7 open drain function |
| P6.0 ~P6.7 | PORT6 | PORT6 can be INPUT or OUTPUT port each bit. And shared with Common signal. |
| P9.0 ~P9.7 | PORT9 | PORT 9 can be INPUT or OUTPUT port each bit. And shared with Segment signal. Bit6,7 has wake-up function. |
| TEST | I | Test pin into test mode , normal low |
| TONE | O | Tone generator's output |
| RESET | I | |

VII.Functional Descriptions

VII.1 Operational Registers

1. R0 (Indirect Addressing Register)

* R0 is not a physically implemented register. It is useful as indirect addressing pointer. Any instruction using R0 as register actually accesses data pointed by the RAM Select Register (R4).

2. R1 (TCC)

* Increased by an external signal edge applied to TCC , or by the instruction cycle clock.

Written and read by the program as any other register.

3. R2 (Program Counter)

* The structure is depicted in Fig.3

* Generates $8K \times 13$ on-chip ROM addresses to the relative programming instruction codes.

* "JMP" instruction allows the direct loading of the low 10 program counter bits.

* "CALL" instruction loads the low 10 bits of the PC, PC+1, and then push into the stack.

* "RET" ("RETL k", "RETI") instruction loads the program counter with the contents at the top of stack.

* "MOV R2,A" allows the loading of an address from the A register to the PC, and the ninth and tenth bits are cleared to "0".

- * "ADD R2,A" allows a relative address be added to the current PC, and contents of the ninth and tenth bits are cleared to "0".
- * "TBL" allows a relative address be added to the current PC, and contents of the ninth and tenth bits don't change. The bits A10~A12 will be loaded with the content of bit PS0~PS2 in the status register (R5) upon the execution of a "JMP", "CALL", "ADD R2,A", or "MOV R2,A" instruction.

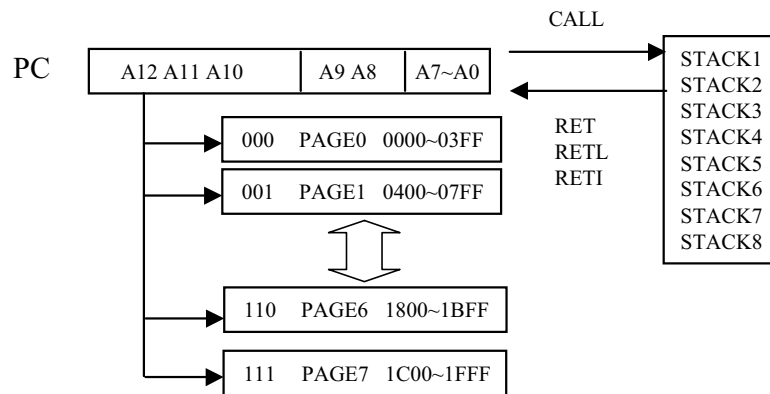

Fig.3 Program counter organization

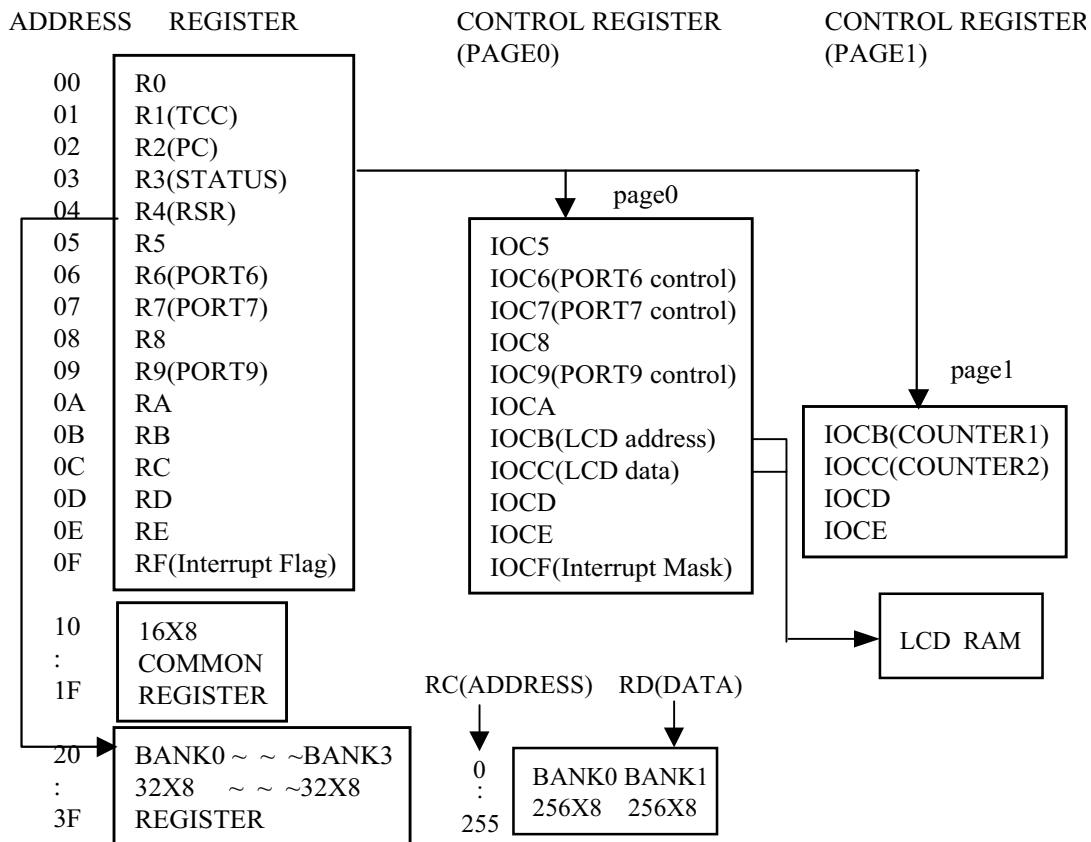

Fig.4 Data memory configuration

4. R3 (Status Register)

| | | | | | | | |
|------|---------|---------|---|---|---|----|---|
| 7 | 6 | 5 | 4 | 3 | 2 | 1 | 0 |
| PAGE | P_TONE2 | P_TONE1 | T | P | Z | DC | C |

- * Bit 0 (C) Carry flag
- * Bit 1 (DC) Auxiliary carry flag
- * Bit 2 (Z) Zero flag
- * Bit 3 (P) Power down bit. Set to 1 during power on or by a "WDTC" command and reset to 0 by a "SLEP" command.
- * Bit 4 (T) Time-out bit. Set to 1 by the "SLEP" and "WDTC" command, or during power up and reset to 0 by WDT timeout.

| EVENT | T | P | REMARK |
|------------------------------------|---|---|-----------------|
| WDT wake up from sleep mode | 0 | 0 | |
| WDT time out (not sleep mode) | 0 | 1 | |
| /RESET wake up from sleep power up | 1 | 0 | |
| | 1 | 1 | |
| Low pulse on /RESET | x | x | x .. don't care |

- *Bit5: Power control bit of Tone generator 1 . User can use this bit to power on the tone generator.
- *Bit6: Power control bit of Tone generator 2 . User can use this bit to power on the tone generator.

Tone frequency controlled by IOCD and IOCE.

| | | |
|---------|-----------------|-----------------|
| R4(6,5) | Tone generator2 | Tone generator1 |
| 00 | Power off | Power off |
| 01 | Power off | Power on |
| 10 | Power on | Power off |
| 11 | Power on | Power on |

* Bit 7 PAGE : change IOCB ~ IOCE to another page , 0/1 => page0 / page1

5. R4 (RAM Select Register)

- * Bits 0 ~ 5 are used to select up to 64 registers in the indirect addressing mode.
- * Bits 6 ~ 7 determine which bank is activated among the 4 banks.
- * See the configuration of the data memory in Fig. 5.

6. R5 (Program Page Select Register)

| | | | | | | | |
|-----|-----|-----|-----|---|-----|-----|-----|
| 7 | 6 | 5 | 4 | 3 | 2 | 1 | 0 |
| R57 | R56 | R55 | R54 | x | PS2 | PS1 | PS0 |

* Bit 0 (PS0) ~ Bit2 (PS2) : Page select bits should be set before JMP or CALL instruction.

Page select bits

| PS1 | PS1 | PS0 | Program memory page (Address) |
|-----|-----|-----|-------------------------------|
| 0 | 0 | 0 | Page 0 |
| 0 | 0 | 1 | Page 1 |
| 0 | 1 | 0 | Page 2 |
| 0 | 1 | 1 | Page 3 |
| 1 | 0 | 0 | Page 4 |
| 1 | 0 | 1 | Page 5 |
| 1 | 1 | 0 | Page 6 |
| 1 | 1 | 1 | Page 7 |

User can use PAGE instruction to change page. To maintain program page by user. Otherwise, user can use far jump (FJMP) or far call (FCALL) instructions to program user's code. And the program page is maintained by EMC's compiler. It will change user's program by inserting instructions within program.

* **Bit3: unused**

*Bit4 ~7: 4-bit I/O registers.

6. R6 ~ R9 (Port 6 ~ Port 9)

* R6, R7 and R9 are three 8-bit I/O registers for Port6, Port7 and Port9. **R8 is unaccess.**

7. RA

| | | | | | | | |
|------|-------|------|------|---|---|---|---|
| 7 | 6 | 5 | 4 | 3 | 2 | 1 | 0 |
| IDLE | /358E | CLK2 | CLK1 | x | x | x | x |

* **Bit0~Bit3 : unused**

* Bit4~ Bit5: MAIN clock selection bits.

User can choose the main clock by CLK1 and CLK2. All the clock is list below.

| CLK2, CLK1 | MAIN clock | /358E | CPU's clock |
|------------|------------|-------|-------------|
| 0,0 | 0.447MHz | 1 | 0.447MHz |
| 0,1 | 0.895MHz | 1 | 0.895MHz |
| 1,0 | 1.79MHz | 1 | 1.79MHz |

| | | | |
|-----|----------|---|----------|
| 1,1 | 3.579MHz | 1 | 3.579MHz |
| 0,0 | X | 0 | 32768HZ |
| 0,1 | X | 0 | 32768HZ |
| 1,0 | X | 0 | 32768HZ |
| 1,1 | X | 0 | 32768HZ |

* Bit6(read/write)(PLL enable signal)
 0/1=DISABLE/ENABLE

The relation between 32.768kHz and 3.579MHz can see Fig.6

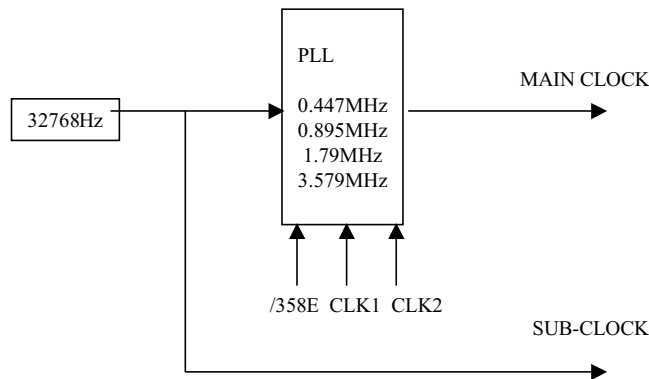

Fig.6 The relation between 32.768kHz and 3.579MHz .

* Bit7 IDLE: sleep mode selection bit

0/1=sleep mode/IDLE mode. This bit will decide SLEP instruction which mode to go.

These two modes can be waken up by TCC clock or Watch Dog or PORT9 and run from “SLEP” next instruction.

| Wakeup signal | SLEEP mode | IDLE mode | GREEN mode | NORMAL mode |
|---------------|-------------------------|--|--------------------------|--------------------------|
| | RA(7,6)=(0,0) + SLEP | RA(7,6)=(1,0) + SLEP | RA(7,6)=(x,0) no SLEP | RA(7,6)=(x,1) no SLEP |
| TCC time out | X | Wake-up + Interrupt + Next instruction | Interrupt | Interrupt |
| WDT time out | RESET | Wake-up + Next instruction | RESET | RESET |
| Port96,97 | RESET | Wake-up + Next instruction | X | X |
| PORT70~73 | RESET | Wake-up + Interrupt + Next instruction | Interrupt | Interrupt |

*P70 ~ P73 's wakeup function is controlled by IOCF(1,2,3) and ENI instruction.

*P70 's wakeup signal is a rising or falling signal defined by CONT REGISTER bit7.

*Port96,Port97 ,Port71,Port72 and Port73 's wakeup signal is a falling edge signal.

8. RB

| | | | | | | | |
|---|---|---|---|---------|---|------|--------|
| 7 | 6 | 5 | 4 | 3 | 2 | 1 | 0 |
| x | x | x | x | LOW_BAT | x | /LPD | CALL_1 |

*Bit0: Two blocks of CALLER ID RAM area. User can use 0.5K RAM with RC ram address.
 0/1 → RAM bank0/RAM bank1

*Bit1(/LPD): Low battery detect disable/enable, 0/1= disable/enable

*Bit2 : unused

*Bit3(LOW_BAT):Low battery signal, 0/1 = battery voltage is low/normal.

If the battery voltage is under 2.5V then sends a '0' signal to RA register bit4 or a '1' signal to this Bit if VDD is over 2.6V.

The relation between /LPD,/POVD and /LOW_BAT can see Fig..7

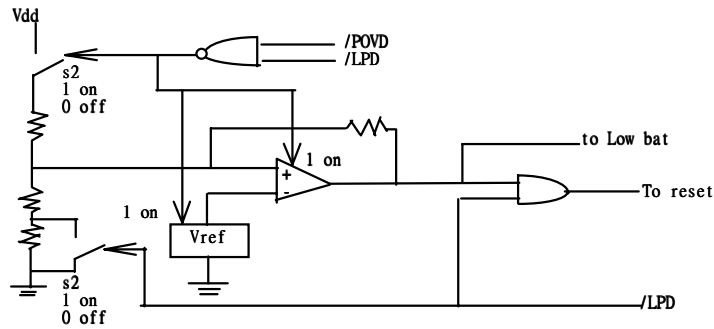

Fig.7 The relation between /LPD,/POVD

* Bit 4~ 7: unused

9. RC

| | | | | | | | |
|-------|-------|-------|-------|-------|-------|-------|-------|
| 7 | 6 | 5 | 4 | 3 | 2 | 1 | 0 |
| CIDA7 | CIDA6 | CIDA5 | CIDA4 | CIDA3 | CIDA2 | CIDA1 | CIDA0 |

* Bit 0 ~ Bit 7 select CALLER ID RAM address up to 256.

10. RD

* Bit 0 ~ Bit 8 are CALLER ID RAM data transfer register.

User can see RB register how to select CID RAM banks.

11. RE

| | | | | | | | |
|---|-------|--------|--------|---|--------|--------|-------|
| 7 | 6 | 5 | 4 | 3 | 2 | 1 | 0 |
| x | /WDTE | /WUP97 | /WUP96 | x | LCD_C2 | LCD_C1 | LCD_M |

* Bit0 (LCD_M):LCD_M decides the methods, including duty, bias, and frame frequency.

* Bit1~Bit2 (LCD_C#):LCD_C# decides the LCD display enable or blanking. change the display duty must set the "LCD_C2,LCD_C1" to "00".

| LCD_C2,LCD_C1 | LCD Display Control | LCD_M | duty | bias |
|---------------|-----------------------|-------|------|------|
| 0 0 | Change duty | 0 | 1/16 | 1/4 |
| | Disable(turn off LCD) | 1 | 1/8 | 1/4 |
| 0 1 | Blanking | : | : | : |
| 1 1 | LCD display enable | : | : | : |

* Bit3 : unused

* Bit4 (/WUP96, PORT9 bit6 Wake Up Enable): used to enable the wake-up function of PORT9 bit6 . (1/0=enable/disable)

* Bit5 (/WUP97, PORT9 bit7 Wake Up Enable): used to enable the wake-up function of PORT9 bit7 . (1/0=enable/disable)

* Bit6 (/WDTE,Watch Dog Timer Enable)

Control bit used to enable Watchdog timer.

(1/0=enable/disable)

* Bit7 : unused

12. RF (Interrupt Status Register)

| | | | | | | | |
|---|---|------|------|-----------|------|------|------|
| 7 | 6 | 5 | 4 | 3 | 2 | 1 | 0 |
| x | x | C8_2 | C8_1 | INT2/INT3 | INT1 | INT0 | TCIF |

- * "1" means interrupt request, "0" means non-interrupt
- * Bit 0 (TCIF) TCC timer overflow interrupt flag. Set when TCC timer overflows .
- * Bit 1 (INT0) external INT0 pin interrupt flag .
- * Bit 2 (INT1) external INT1 pin interrupt flag .
- * Bit 3 (INT2/INT3) external INT2 and INT3 pin interrupt flag .
- * Bit 4 (C8_1) internal 8 bit counter interrupt flag .
- * Bit 5 (C8_2) internal 8 bit counter interrupt flag .
- * **Bit 6~7 : unused**
- * High to low edge trigger , Refer to the Interrupt subsection. (INT0 can be triggered by low to high signal , refer to CONT bit 7)
- * IOCF is the interrupt mask register. User can read and clear.

13. R10~R3F (General Purpose Register)

- * R10~R3F (Banks 0~3) all are general purpose registers.

VII.2 Special Purpose Registers

1. A (Accumulator)

- * Internal data transfer, or instruction operand holding
- * It's not an addressable register.

2. CONT (Control Register)

| | | | | | | | |
|----------|-----|----|---|-----|------|------|------|
| 7 | 6 | 5 | 4 | 3 | 2 | 1 | 0 |
| INT_EDGE | INT | TS | - | PAB | PSR2 | PSR1 | PSR0 |

- * Bit 0 (PSR0) ~ Bit 2 (PSR2) TCC/WDT prescaler bits.

| PSR2 | PSR1 | PSR0 | TCC Rate | WDT Rate |
|------|------|------|----------|----------|
| 0 | 0 | 0 | 1:2 | 1:1 |
| 0 | 0 | 1 | 1:4 | 1:2 |
| 0 | 1 | 0 | 1:8 | 1:4 |
| 0 | 1 | 1 | 1:16 | 1:8 |
| 1 | 0 | 0 | 1:32 | 1:16 |
| 1 | 0 | 1 | 1:64 | 1:32 |
| 1 | 1 | 0 | 1:128 | 1:64 |
| 1 | 1 | 1 | 1:256 | 1:128 |

- * Bit 3 (PAB) Prescaler assignment bit.
0/1 : TCC/WDT
- * Bit 4 unused
- * Bit 5 (TS) TCC signal source
0: internal instruction cycle clock
1: 16.38KHz
- * Bit 6 : (INT)INT enable flag
0: interrupt masked by DISI or hardware interrupt
1: interrupt enabled by ENI/RETI instructions
- * Bit 7 : INT_EDGE

0:P70 's interruption source is a rising edge signal.
1:P70 's interruption source is a falling edge signal.

* CONT register is readable and writable.

3. IOC5

| | | | | | | | |
|-------|-------|-------|-------|---|---|---|---|
| 7 | 6 | 5 | 4 | 3 | 2 | 1 | 0 |
| IOC54 | IOC54 | IOC54 | IOC54 | x | x | x | x |

***Bit0 ~ Bit3 : unused**

*Bit4~Bit7: I/O direction control registers of PORT5.

* "1" put the relative I/O pin into high impedance (input port), while "0" put the relative I/O pin as output.

4. IOC6 ~ IOC9 (I/O Port Control Register)

* IOC6, IOC7 and IOC9 are three I/O direction control registers.

* "1" put the relative I/O pin into high impedance (input port), while "0" put the relative I/O pin as output.

* **IOC8 is unaccess.**

5. IOCA

| | | | | | | | |
|------|------|-----|-----|-------|-------|-------|----|
| 7 | 6 | 5 | 4 | 3 | 2 | 1 | 0 |
| P9SH | P9SL | P6S | P5S | Bias3 | Bias2 | Bias1 | SC |

* Bit 0 :SC (SCAN KEY signal) 0/1 = disable/enable. Once you enable this bit , all of the LCD signal will have a low pulse during a common period. This pulse has 30us width. Please use the procedure to implement the key scan function.

- set port7 as input port
- set IOCD page0 port7 pull high
- enable scan key signal
- Once push a key . Set RA(6)=1 and switch to normal mode.
- Blank LCD. Disable scan key signal.
- Set P6S =0. Port6 sent probe signal to port7 and read port7. Get the key.
- Note!! A probe signal should be delay a instruction at least to another probe signal.
- Set P6S =1. Port6 as LCD signal. Enable LCD.

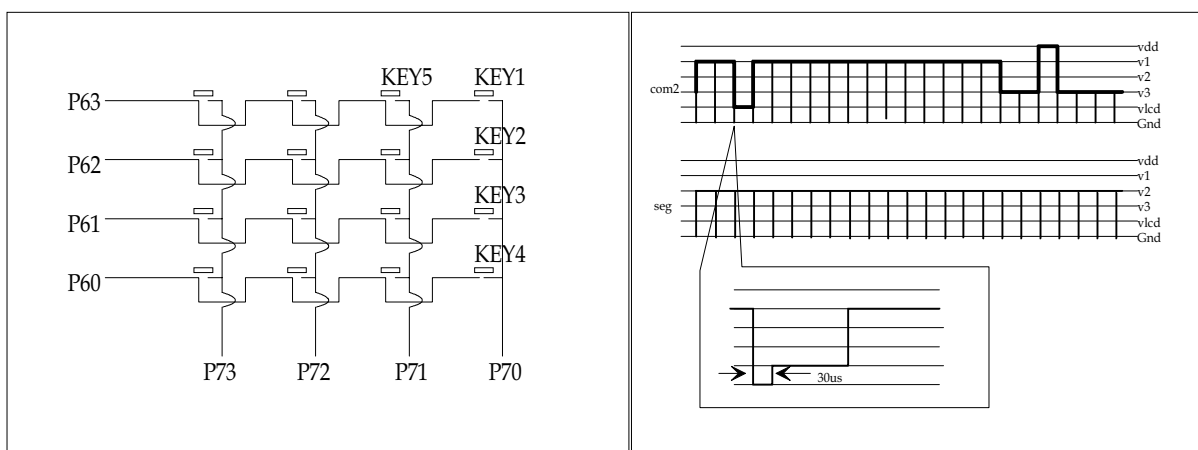

Fig.9 Key scan circuit

* Bit 3~1 (Bias3~Bias1) Control bits used to choose LCD operation voltage .

| LCD operate voltage | Vop (VDD 3.3V) | VDD=3.3V |
|---------------------|----------------|--------------|
| 000 | 0.60VDD | 1.98V |
| 001 | 0.66VDD | 2.18V |
| 010 | 0.74VDD | 2.44V |
| 011 | 0.82VDD | 2.71V |
| 100 | 0.87VDD | 2.87V |
| 101 | 0.93VDD | 3.07V |
| 110 | 0.96VDD | 3.17V |
| 111 | 1.00VDD | 3.3V |

* Bit4: port5 nibble switch, 0/1= normal I/O port/SEGMENT output .

* Bit5:port6 switch , 0/1= normal I/O port/COMMON output

* Bit6:port9 low nibble switch , 0/1= normal I/O port/SEGMENT output . Bit7:port9 high nibble switch

6. IOCB (LCD ADDRESS)

PAGE0 : Bit6 ~ Bit0 = LCDA6 ~ LCDA0

The LCD display data is stored in the data RAM . The relation of data area and COM/SEG pin is as below:

| COM15 ~ COM8 | COM7 ~ COM0 | |
|--------------------|-------------------|-------|
| 40H (Bit15 ~ Bit8) | 00H (Bit7 ~ Bit0) | SEG0 |
| 41H | 01H | SEG1 |
| : | : | : |
| 67H | 27H | SEG39 |
| : | : | Empty |
| 7FH | 3FH | Empty |

PAGE1 : 8 bit up-counter (COUNTER1) preset and read out register . (write = preset) . After a interruption , it will count from "00".

7. IOCC (LCD DATA)

PAGE0 : Bit7 ~ Bit0 = LCD RAM data register

PAGE1 : 8 bit up-counter (COUNTER2) preset and read out register . (write = preset) After a interruption , it will count from "00".

8. IOCD

PAGE0 :

| 7 | 6 | 5 | 4 | 3 | 2 | 1 | 0 |
|-----|-----|-----|-----|-----|-----|-----|-----|
| T17 | T16 | T15 | T14 | T13 | T12 | T11 | T10 |

Tone generator 1 's frequency divider. Please Run in Normal mode .

Clock source = 111843Hz

T17~T10 = '11111111' => Tone generator1 will has 438Hz SIN wave output.

:

T17~T10 = '00000010' => Tone generator1 will has 55921Hz SIN wave output.

T17~T10 = '00000001' => Tone generator1 will has 111843Hz

T17~T10 = '00000000' => no used

PAGE1:

| 7 | 6 | 5 | 4 | 3 | 2 | 1 | 0 |
|-----|-----|-----|-----|-----|-----|-----|-----|
| PH7 | PH6 | PH5 | PH4 | PH3 | PH2 | PH1 | PH0 |

- * Bit 0 ~ 7 (/PH#) Control bit used to enable the pull-high of PORT7(#) pin.
1: Enable internal pull-high
0: Disable internal pull-high

9. IOCE

PAGE0 :

| | | | | | | | |
|-----|-----|-----|-----|-----|-----|-----|-----|
| 7 | 6 | 5 | 4 | 3 | 2 | 1 | 0 |
| T27 | T26 | T25 | T24 | T23 | T22 | T21 | T20 |

Tone generator 2 's frequency divider. Please Run in Normal mode.

Clock source = 111843Hz

T27~T20 = '11111111' => Tone generator1 will has 438Hz SIN wave output.

:

T27~T20 = '00000010' => Tone generator1 will has 55921Hz SIN wave output.

T27~T20 = '00000001' => Tone generator1 will has 111843Hz SIN wave output.

T27~T20 = '00000000' => no used

| TONE1(IOCD) | ROW FREQ. | | | | |
|-------------|-----------|---------------|--------------|--------------|--------------|
| (0xA0) | 699.02Hz | 1 | 2 | 3 | A |
| (0x91) | 771.33Hz | 4 | 5 | 6 | B |
| (0X83) | 853.76Hz | 7 | 8 | 9 | C |
| (0X77) | 939.86Hz | * | 0 | # | D |
| | | 1202.6 (0X5D) | 1331.5(0X54) | 1471.7(0X4C) | 1644.8(0X44) |
| | | TONE2(IOCE) | | | |

PAGE1 :

| | | | | | | | |
|------|------|-----|-----|------|------|------|---|
| 7 | 6 | 5 | 4 | 3 | 2 | 1 | 0 |
| OP77 | OP76 | C2S | C1S | PSC2 | PSC1 | PSC0 | x |

* Bit0 : unused

- * Bit3~Bit1: counter1 prescaler , reset=(0,0,0)

| (PSC2,PSC1,PSC0) | Scaler |
|------------------|--------|
| 0,0,0 | 1:1 |
| 0,0,1 | 1:2 |
| 0,1,0 | 1:4 |
| 0,1,1 | 1:8 |
| 1,0,0 | 1:16 |
| 1,0,1 | 1:32 |
| 1,1,0 | 1:64 |
| 1,1,1 | 1:128 |

- * Bit4:counter1 source , (0/1)=(32768Hz/MAIN clock if enable)

- * Bit5:counter2 source , (0/1)=(32768Hz/MAIN clock if enable) scale=1:1

- * Bit6:P76 opendrain control (0/1)=(disable/enable)

- * Bit7:P77 opendrain control (0/1)=(disable/enable)

10. IOCF (Interrupt Mask Register)

| | | | | | | | |
|---|---|------|------|-----------|------|------|------|
| 7 | 6 | 5 | 4 | 3 | 2 | 1 | 0 |
| x | x | C8_2 | C8_1 | INT2/INT3 | INT1 | INT0 | TCIF |

- * Bit 0 ~ 5 interrupt enable bit.

0: disable interrupt
1: enable interrupt

* Bit 6,7 : unused

- * IOCF Register is readable and writable.

VII.3 TCC/WDT Prescaler

There is an 8-bit counter available as prescaler for the TCC or WDT. The prescaler is available for the TCC only or WDT only at the same time.

- An 8 bit counter is available for TCC or WDT determined by the status of the bit 3 (PAB) of the CONT register.
- See the prescaler ratio in CONT register.
- Fig. 10 depicts the circuit diagram of TCC/WDT.
- Both TCC and prescaler will be cleared by instructions which write to TCC each time.
- The prescaler will be cleared by the WDTC and SLEP instructions, when assigned to WDT mode.
- The prescaler will not be cleared by SLEP instructions, when assigned to TCC mode.

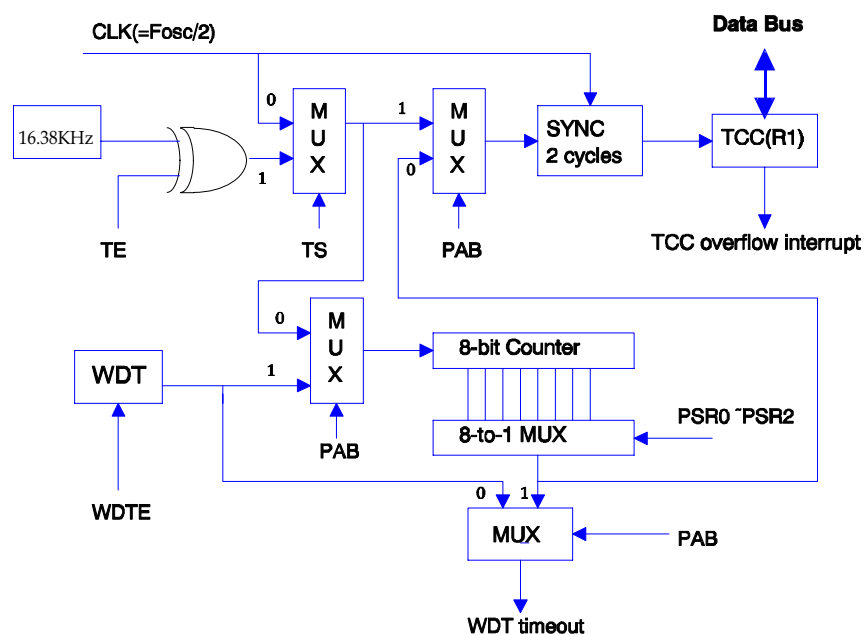

Fig.10 Block diagram of TCC WDT

VII.4 I/O Ports

The I/O registers, Port5 ~ Port 9, are bi-directional tri-state I/O ports. Port 7 can be pulled-high internally by software control. The I/O ports can be defined as "input" or "output" pins by the I/O control registers (IOC6 ~ IOC9) under program control. The I/O registers and I/O control registers are both readable and writable. The I/O interface circuit is shown in Fig.11.

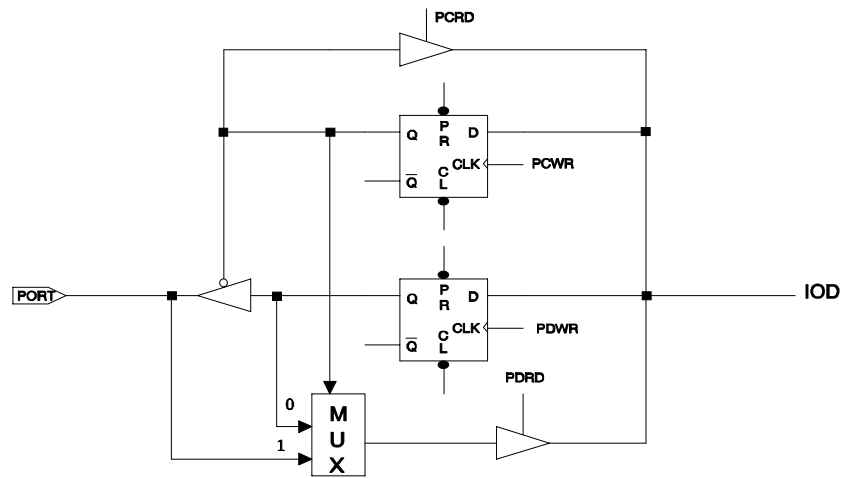

Fig.11 The circuit of I/O port and I/O control register

VII.5 RESET and Wake-up

The RESET can be caused by

- (1) Power on reset, or Voltage detector
- (2) WDT timeout. (if enabled and in GREEN or NORMAL mode)

Note that only Power on reset, or only Voltage detector in Case(1) is enabled in the system by CODE Option bit. If Voltage detector is disabled, Power on reset is selected in Case (1). Refer to Fig. 12.

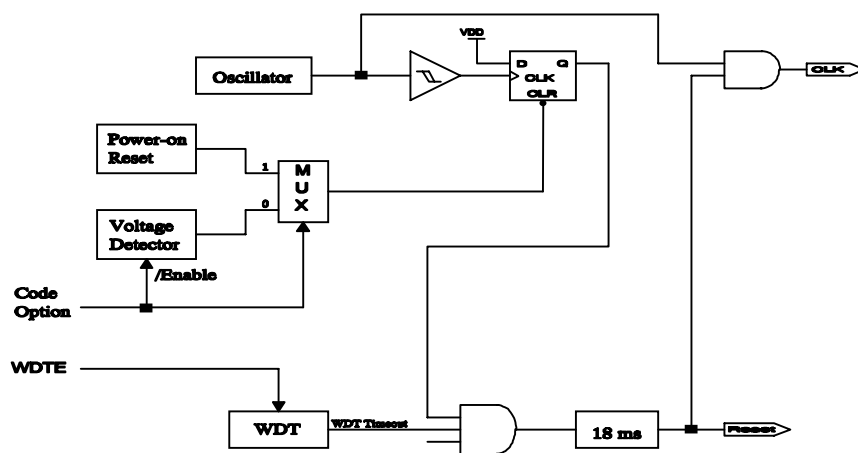

Fig.12 Block diagram of Reset of controller

Once the RESET occurs, the following functions are performed.

- The oscillator is running, or will be started.
- The Program Counter (R2) is set to all "0".
- When power on, the upper 3 bits of R3 and the upper 2 bits of R4 are cleared.
- The Watchdog timer and prescaler are cleared.
- The Watchdog timer is disabled.
- The CONT register is set to all "1"
- The other register (bit7..bit0)

| | | |
|-----------------|-------------------------|-------------------------|
| R5 = "xxx0000" | IOC5 = "1111xxxx" | |
| R6 = PORT | IOC6 = "11111111" | |
| R7 = PORT | IOC7 = "11111111" | |
| R8 = (unaccess) | IOC8 = (unaccess) | |
| R9 = PORT | IOC9 = "11111111" | |
| RA = "00000000" | IOCA = "00000000" | |
| RB = "00000000" | Page0 IOCB = "00000000" | Page1 IOCB = "00000000" |
| RC = "00000000" | Page0 IOCC = "0xxxxxxx" | Page1 IOCC = "00000000" |
| RD = "xxxxxxx" | Page0 IOCD = "00000000" | Page1 IOCD = "00000000" |
| RE = "x0000000" | Page0 IOCE = "00000000" | Page1 IOCE = "00000000" |
| RF = "xx000000" | IOCF = "xx000000" | |

The controller can be awakened from SLEEP mode or IDLE mode (execution of "SLEP" instruction, named as SLEEP MODE or IDLE mode) by (1)TCC time out (IDLE mode only) (2) WDT time-out (if enabled) or, (3) external input at PORT9 (4)RINGTIME pin. The four cases will cause the controller wake up and run from next instruction in IDLE mode, reset in SLEEP mode. After wake-up, user should control WATCH DOG in case of reset in GREEN mode or NORMAL mode. The last three should be open RE register before into SLEEP mode or IDLE mode. The first one case will set a flag in RF bit0. And it will go to address 0x08 when TCC generate a interrupt.

VII.6 Interrupt

The CALLER ID IC has internal interrupts which are falling edge triggered, as followed: TCC timer overflow interrupt (internal), two 8-bit counters overflow interrupt.

If these interrupt sources change signal from high to low, then RF register will generate '1' flag to corresponding register if you enable IOCF register.

RF is the interrupt status register which records the interrupt request in flag bit. IOCF is the interrupt mask register. Global interrupt is enabled by ENI instruction and is disabled by DISI instruction. When one of the interrupts (when enabled) generated, will cause the next instruction to be fetched from address 008H. Once in the interrupt service routine the source of the interrupt can be determined by polling the flag bits in the RF register. The interrupt flag bit must be cleared in software before leaving the interrupt service routine and enabling interrupts to avoid recursive interrupts.

There are four external interrupt pins including INT0, INT1, INT2, INT3. And four internal counter interrupt available.

External interrupt INT0, INT1, INT2, INT3 signals are from PORT7 bit0 to bit3. If IOCF is enable then these signal will cause interrupt, or these signals will be treated as general input data.

After reset, the next instruction will be fetched from address 000H and the instruction inturrept is 001H and the hardware inturrept is 008H.

TCC will go to address 0x08 in GREEN mode or NORMAL mode after time out. And it will run next instruction from "SLEP" instruction and then go to address 0x08 in IDLE mode. These two cases will set a RF flag.

VII.7 Instruction Set

Instruction set has the following features:

- (1). Every bit of any register can be set, cleared, or tested directly.
- (2). The I/O register can be regarded as general register. That is, the same instruction can operates on I/O register.

The symbol "R" represents a register designator which specifies which one of the 64 registers (including operational registers and general purpose registers) is to be utilized by the instruction. Bits 6 and 7 in R4 determine the selected register bank. "b" represents a bit field designator which selects the number of the bit, located in the register "R", affected by the operation. "k" represents an 8 or 10-bit constant or literal value.

| INSTRUCTION BINARY | HEX | MNEMONIC | OPERATION | STATUS AFFECTED |
|--------------------|------|----------|---|-----------------|
| 0 0000 0000 0000 | 0000 | NOP | No Operation | None |
| 0 0000 0000 0001 | 0001 | DAA | Decimal Adjust A | C |
| 0 0000 0000 0010 | 0002 | CONTW | A → CONT | None |
| 0 0000 0000 0011 | 0003 | SLEP | 0 → WDT, Stop oscillator | T,P |
| 0 0000 0000 0100 | 0004 | WDTC | 0 → WDT | T,P |
| 0 0000 0000 rrrr | 000r | IOW R | A → IOCR | None |
| 0 0000 0001 0000 | 0010 | ENI | Enable Interrupt | None |
| 0 0000 0001 0001 | 0011 | DISI | Disable Interrupt | None |
| 0 0000 0001 0010 | 0012 | RET | [Top of Stack] → PC | None |
| 0 0000 0001 0011 | 0013 | RETI | [Top of Stack] → PC Enable Interrupt | None |
| 0 0000 0001 0100 | 0014 | CONTR | CONT → A | None |
| 0 0000 0001 rrrr | 001r | IOR R | IOCR → A | None |
| 0 0000 0010 0000 | 0020 | TBL | R2+A → R2 bits 9,10 do not clear | Z,C,DC |
| 0 0000 01rr rrrr | 00rr | MOV R,A | A → R | None |
| 0 0000 1000 0000 | 0080 | CLRA | 0 → A | Z |
| 0 0000 11rr rrrr | 00rr | CLR R | 0 → R | Z |
| 0 0001 00rr rrrr | 01rr | SUB A,R | R-A → A | Z,C,DC |
| 0 0001 01rr rrrr | 01rr | SUB R,A | R-A → R | Z,C,DC |
| 0 0001 10rr rrrr | 01rr | DECA R | R-1 → A | Z |
| 0 0001 11rr rrrr | 01rr | DEC R | R-1 → R | Z |
| 0 0010 00rr rrrr | 02rr | OR A,R | A ∨ VR → A | Z |
| 0 0010 01rr rrrr | 02rr | OR R,A | A ∨ VR → R | Z |
| 0 0010 10rr rrrr | 02rr | AND A,R | A & R → A | Z |
| 0 0010 11rr rrrr | 02rr | AND R,A | A & R → R | Z |
| 0 0011 00rr rrrr | 03rr | XOR A,R | A ⊕ R → A | Z |
| 0 0011 01rr rrrr | 03rr | XOR R,A | A ⊕ R → R | Z |
| 0 0011 10rr rrrr | 03rr | ADD A,R | A + R → A | Z,C,DC |
| 0 0011 11rr rrrr | 03rr | ADD R,A | A + R → R | Z,C,DC |
| 0 0100 00rr rrrr | 04rr | MOV A,R | R → A | Z |
| 0 0100 01rr rrrr | 04rr | MOV R,R | R → R | Z |
| 0 0100 10rr rrrr | 04rr | COMA R | /R → A | Z |
| 0 0100 11rr rrrr | 04rr | COM R | /R → R | Z |
| 0 0101 00rr rrrr | 05rr | INCA R | R+1 → A | Z |
| 0 0101 01rr rrrr | 05rr | INC R | R+1 → R | Z |
| 0 0101 10rr rrrr | 05rr | DJZA R | R-1 → A, skip if zero | None |
| 0 0101 11rr rrrr | 05rr | DJZ R | R-1 → R, skip if zero | None |
| 0 0110 00rr rrrr | 06rr | RRCA R | R(n) → A(n-1) R(0) → C, C → A(7) | C |
| 0 0110 01rr rrrr | 06rr | RRC R | R(n) → R(n-1) R(0) → C, C → R(7) | C |
| 0 0110 10rr rrrr | 06rr | RLCA R | R(n) → A(n+1) R(7) → C, C → A(0) | C |
| 0 0110 11rr rrrr | 06rr | RLC R | R(n) → R(n+1) R(7) → C, C → R(0) | C |
| 0 0111 00rr rrrr | 07rr | SWAPA R | R(0-3) → A(4-7) R(4-7) → A(0-3) | None |
| 0 0111 01rr rrrr | 07rr | SWAP R | R(0-3) ↔ R(4-7) | None |



| | | | | | | | |
|----------|-------------|-------------|-------------|-------------|---------------|-------------------------------|-------------|
| 0 | 0111 | 10rr | rrrr | 07rr | JZA R | R+1 → A, skip if zero | None |
| 0 | 0111 | 11rr | rrrr | 07rr | JZ R | R+1 → R, skip if zero | None |
| 0 | 100b | bbrr | rrrr | 0xxx | BC R,b | 0 → R(b) | None |
| 0 | 101b | bbrr | rrrr | 0xxx | BS R,b | 1 → R(b) | None |
| 0 | 110b | bbrr | rrrr | 0xxx | JBC R,b | if R(b)=0, skip | None |
| 0 | 111b | bbrr | rrrr | 0xxx | JBS R,b | if R(b)=1, skip | None |
| 1 | 00kk | kkkk | kkkk | 1kkk | CALL k | PC+1 → [SP] (Page, k) → PC | None |
| 1 | 01kk | kkkk | kkkk | 1kkk | JMP k | (Page, k) → PC | None |
| 1 | 1000 | kkkk | kkkk | 18kk | MOV A,k | k → A | None |
| 1 | 1001 | kkkk | kkkk | 19kk | OR A,k | A ∨ k → A | Z |
| 1 | 1010 | kkkk | kkkk | 1Akk | AND A,k | A & k → A | Z |
| 1 | 1011 | kkkk | kkkk | 1Bkk | XOR A,k | A ⊕ k → A | Z |
| 1 | 1100 | kkkk | kkkk | 1Ckk | RETL k | k → A, [Top of Stack] → PC | None |
| 1 | 1101 | kkkk | kkkk | 1Dkk | SUB A,k | k-A → A | Z,C,DC |
| 1 | 1110 | 0000 | 0001 | 1E01 | INT | PC+1 → [SP] 001H → PC | None |
| 1 | 1110 | 1000 | 0kkk | 1E8k | PAGE k | K->R5 | None |
| 1 | 1111 | kkkk | kkkk | 1Fkk | ADD A,k | k+A → A | Z,C,DC |

CODE Option Register

The IC has one CODE option register which is not part of the normal program memory. The option bits cannot be accessed during normal program execution.

| | | | | | | | |
|---|---|---|---|---|---|-------|---|
| 7 | 6 | 5 | 4 | 3 | 2 | 1 | 0 |
| - | - | - | - | - | - | /POVD | - |

* Bit 0 : unused, must be "0".

* **Bit 0 : (/POVD) : Power on voltage detector.**

0: enable

1: disable

| | 2.0V POVD reset | 1.6V power on reset | 2.5V voltage detect no reset | sleep mode current |
|----------|-----------------|---------------------|------------------------------|---------------------|
| 1 | no | yes | no | 1uA typical |
| 0 | yes | yes | yes | 10uA typical |

* Bits 1~7 : unused, must be "0"s.

VII.8 LCD Driver

The CALLER ID IC can drive LCD directly and has 60 segments and 16 commons that can drive 60*16 dots totally. LCD block is made up of LCD driver , display RAM, segment output pins , common output pins and LCD operating power supply pins.

Duty , bias , the number of segment , the number of common and frame frequency are determined by LCD mode register . LCD control register.

The basic structure contains a timing control which uses the basic frequency 32.768KHz to generate the proper timing for different duty and display access. RE register is a command register for LCD driver, the LCD display(disable, enable, blanking) is controlled by LCD_C and the driving duty and bias is decided by LCD_M and the display data is stored in data RAM which address and data access controlled by registers RC and RD.

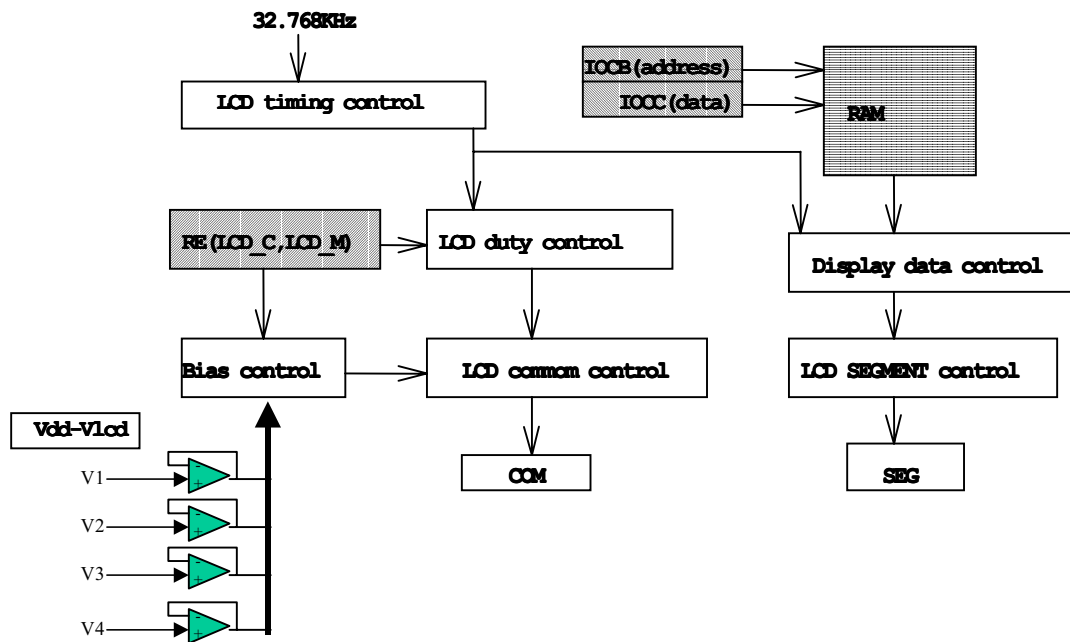

Fig.17 LCD DRIVER CONTROL

VII.8.1 LCD Driver Control

1. RE(LCD Driver Control)(initial state "00000000")

| | | | | | | | |
|---|---|---|---|---|--------|--------|-------|
| 7 | 6 | 5 | 4 | 3 | 2 | 1 | 0 |
| - | - | - | - | - | LCD_C2 | LCD_C1 | LCD_M |

*Bit0 (LCD_M):LCD_M decides the methods, including duty, bias, and frame frequency.

*Bit1~Bit2 (LCD_C#):LCD_C# decides the LCD display enable or blanking. change the display duty must set the LCD_C to "00".

| LCD_C2,LCD_C1 | LCD Display Control | LCD_M | duty | bias |
|---------------|-----------------------|-------|------|------|
| 0 0 | change duty | 0 | 1/16 | 1/4 |
| | Disable(turn off LCD) | 1 | 1/8 | 1/4 |
| 0 1 | Blanking | : | : | : |
| 1 1 | LCD display enable | : | : | : |

VII.8.2 LCD display area

The LCD display data is stored in the data RAM . The relation of data area and COM/SEG pin is as below:

| | | |
|--------------------|-------------------|-------|
| COM15 ~ COM8 | COM7 ~ COM0 | |
| 40H (Bit15 ~ Bit8) | 00H (Bit7 ~ Bit0) | SEG0 |
| 41H | 01H | SEG1 |
| : | : | : |
| : | : | : |
| 67H | 27H | SEG39 |
| : | : | empty |
| 7DH | 3DH | empty |
| 7EH | 3EH | empty |
| 7FH | 3FH | empty |

*IOCB(LCD Display RAM address)

| | | | | | | | |
|---|-------|-------|-------|-------|-------|-------|-------|
| 7 | 6 | 5 | 4 | 3 | 2 | 1 | 0 |
| - | LCDA6 | LCDA5 | LCDA4 | LCDA3 | LCDA2 | LCDA1 | LCDA0 |

Bit 0 ~ Bit 6 select LCD Display RAM address up to 127.

LCD RAM can be write whether in enable or disable mode and read only in disable mode.

*IOCC(LCD Display data) : Bit 0 ~ Bit 8 are LCD data.

VII.8.3 LCD COM and SEG signal

* COM signal : The number of COM pins varies according to the duty cycle used, as following: in 1/8 duty mode COM8 ~ COM15 must be open. in 1/16 duty mode COM0 ~ COM15 pins must be used.

| | COM0 | COM1 | COM2 | COM3 | COM4 | COM5 | COM6 | COM7 | COM8 | .. | COM15 |
|------|------|------|------|------|------|------|------|------|------|----|-------|
| 1/8 | o | o | o | o | o | o | o | o | x | .. | x |
| 1/16 | o | o | o | o | o | o | o | o | o | .. | o |

x:open,o:select

* SEG signal: The 60 segment signal pins are connected to the corresponding display RAM address 00h to 3Bh. The high byte and the low byte bit7 down to bit0 are correlated to COM15 to COM0 respectively .

When a bit of display RAM is 1, a select signal is sent to the corresponding segment pin, and when the bit is 0 , a non-select signal is sent to the corresponding segment pin.

*COM, SEG and Select/Non-select signal is shown as following:

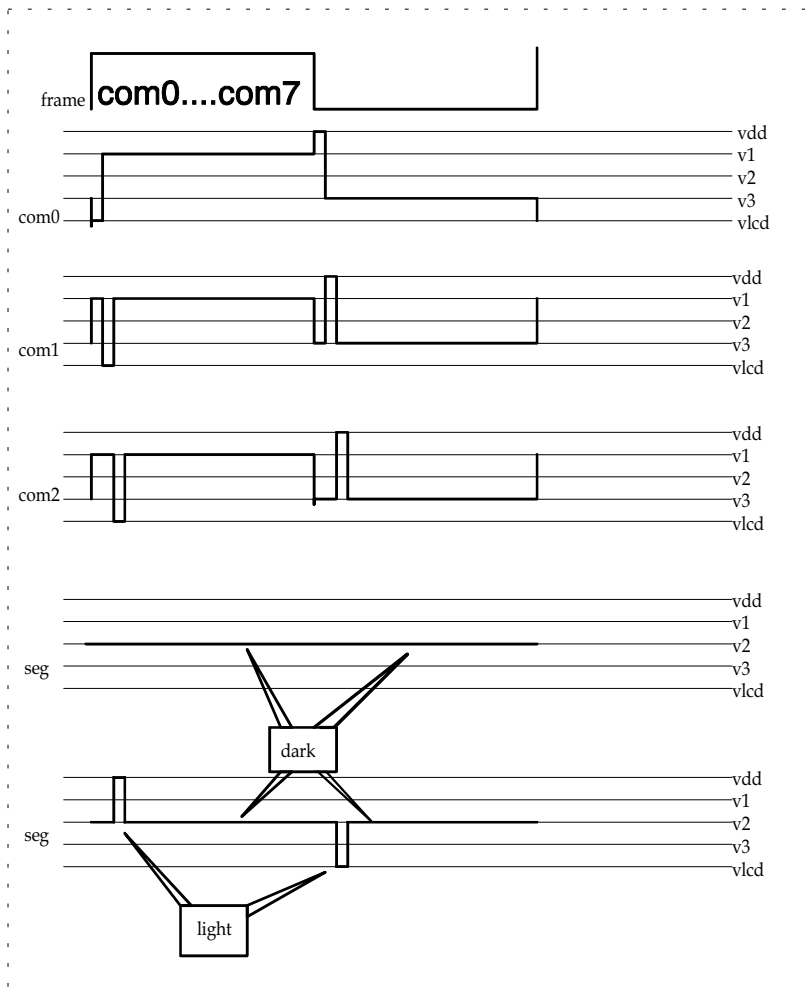

Fig.18 Lcd wave 1/4 bias , 1/8 duty

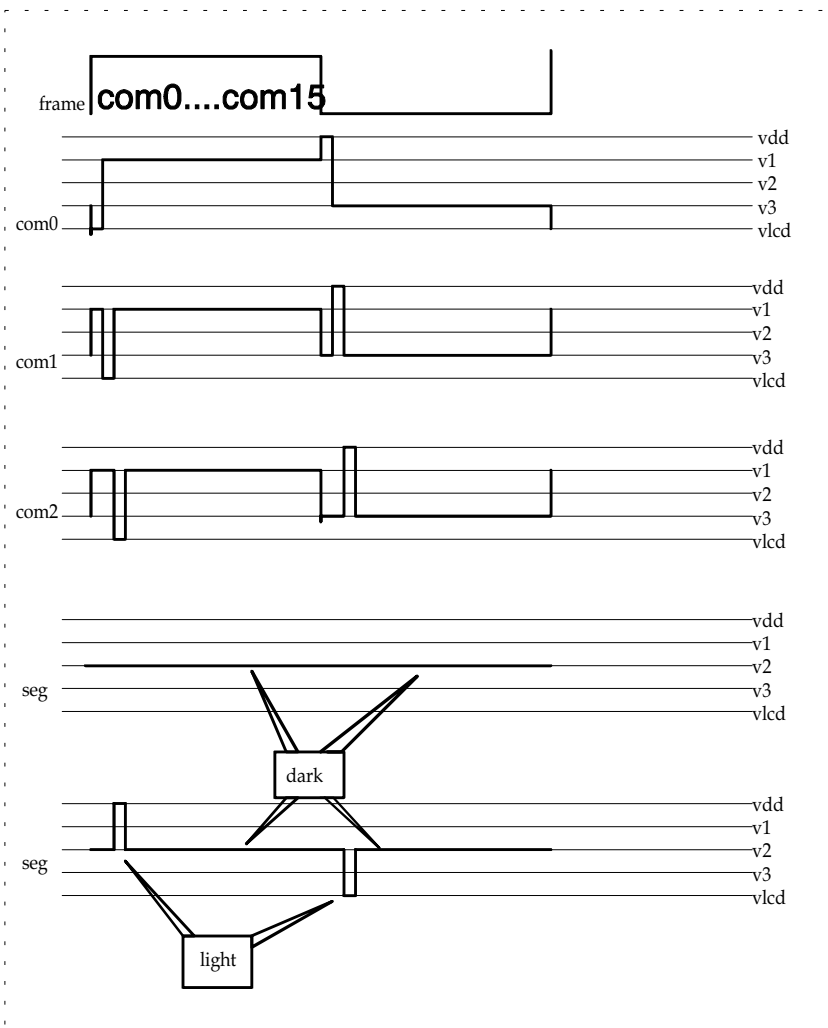

Fig.19 Lcd wave 1/4 bias , 1/16 duty



VIII. Absolute Operation Maximum Ratings

| RATING | SYMBOL | VALUE | UNIT |
|-----------------------------|-----------------|------------------------------|------|
| DC SUPPLY VOLTAGE | V _{dd} | -0.3 To 3.6 | V |
| INPUT VOLTAGE | V _{in} | -0.3 TO V _{dd} +0.3 | V |
| OPERATING TEMPERATURE RANGE | T _a | 0 TO 70 | °C |

IX DC Electrical Characteristic

(T_a=0°C ~ 70°C, V_{DD}=3.3V±5%, V_{SS}=0V)

| Symbol | Parameter | Condition | Min | Typ | Max | Unit |
|--------|--|--|-----|-----------|-----------|------|
| IIL1 | Input Leakage Current for input pins | V _{IN} = V _{DD} , V _{SS} | | | ±1 | μA |
| IIL2 | Input Leakage Current for bi-directional pins | V _{IN} = V _{DD} , V _{SS} | | | ±1 | μA |
| VIH | Input High Voltage | | 2.5 | | | V |
| VIL | Input Low Voltage | | | | 0.8 | V |
| VIHT | Input High Threshold Voltage | /RESET, TCC, RDET1 | 2.0 | | | V |
| VILT | Input Low Threshold Voltage | /RESET, TCC, RDET1 | | | 0.8 | V |
| VIHX | Clock Input High Voltage | OSCI | 3.5 | | | V |
| VILX | Clock Input Low Voltage | OSCI | | | 1.5 | V |
| VHscan | Key scan Input High Voltage | Port6 for key scan | 3.5 | | | V |
| VLscan | Key scan Input Low Voltage | Port6 for key scan | | | 1.5 | V |
| VOH1 | Output High Voltage (port6,7,8) | IOH = -1.6mA | 2.4 | | | V |
| | (port9) | IOH = -6.0mA | 2.4 | | | V |
| VOL1 | Output Low Voltage (port6,7,8) | IOL = 1.6mA | | | 0.4 | V |
| | (port9) | IOL = 6.0mA | | | 0.4 | V |
| Vcom | Com voltage drop | I _o =+/- 50 uA | - | - | 2.9 | V |
| Vseg | Segment voltage drop | I _o =+/- 50 uA | - | - | 3.8 | V |
| Vlcd | LCD drive reference voltage | Contrast adjustment | | | | |
| IPH | Pull-high current | Pull-high active input pin at V _{SS} | | -10 | -15 | μA |
| ISB1 | Power down current (SLEEP mode) POVD disable | All input and I/O pin at V _{DD} , output pin floating, WDT disabled | | 1 | 2 | μA |
| | Power down current (SLEEP mode) POVD enable | | | 6 | 15 | uA |
| ISB2 | Low clock current (GREEN mode) POVD disable | CLK=32.768KHZ, TONE block disable , All input and I/O pin at V _{DD} , output pin floating, WDT disabled, LCD enable | | 30 | 45 | μA |
| | Low clock current (GREEN mode) POVD enable | | | 35 | 55 | uA |
| ISB3 | Low clock current (IDLE mode) POVD disable | CLK=32.768KHZ, TONE block disable , All input and I/O pin at V _{DD} , output pin floating, WDT disabled, LCD enable | | 25 | 40 | μA |
| | Low clock current (IDLE mode) POVD enable | | | 30 | 50 | uA |

| | | | | | | |
|-------|--|--|------------|------------|------------|-----|
| ICC1 | Operating supply current (CPU enable) | /RESET=High, CLK=3.579MHz, output pin floating | | 0.8 | 1.1 | mA |
| Vref2 | Tone generator reference voltage | | 0.5 | | 0.7 | VDD |
| Vmax | Tone1 signal strength | Root mean square voltage | 130 | 155 | 180 | mV |
| Vmax | Tone2 signal strength | Root mean square voltage | 150 | 175 | 200 | mV |
| Ibuf | One LCD bias buffer current | | | 4 | 6 | μA |
| Rbias | LCD bias resistor | | 300 | 400 | 500 | KΩ |

IX AC Electrical Characteristic

(Ta=0°C ~ 70°C, VDD=3.3V, VSS=0V)

| Symbol | Parameter | Conditions | Min | Typ | Max | Unit |
|--------|------------------------|-----------------------|-----------------|-----------|-----|----------|
| Dclk | Input CLK duty cycle | | 45 | 50 | 55 | % |
| Tins | Instruction cycle time | 32.768kHz 3.579MHz | | 60 550 | | us ns |
| Tdrh | Device delay hold time | | | 18 | | ms |
| Ttcc | TCC input period | Note 1 | (Tins+20)/ N | | | ns |
| Twdt | Watchdog timer period | Ta = 25°C | | 18 | | ms |

Note 1: N= selected prescaler ratio.

XI. Timing Diagrams

AC Test Input/Output Waveform

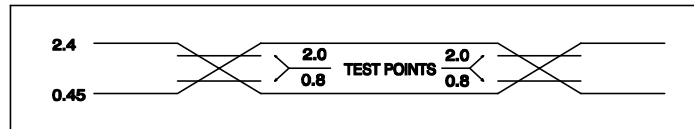

AC Testing: Input are driven at 2.4V for logic "1", and 0.45V for logic "0". Timing measurements are made at 2.0V for logic "1", and 0.8V for logic "0".

RESET Timing

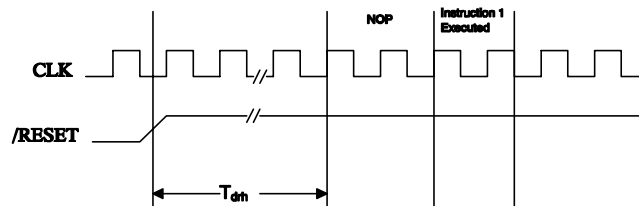

TCC Input Timing

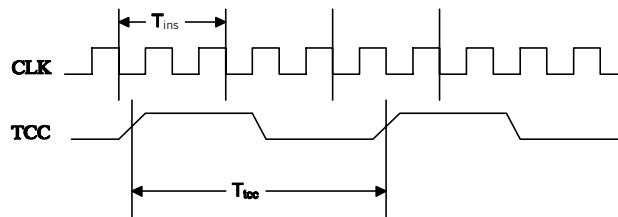

Fig.20 AC timing

XII. Application Circuit

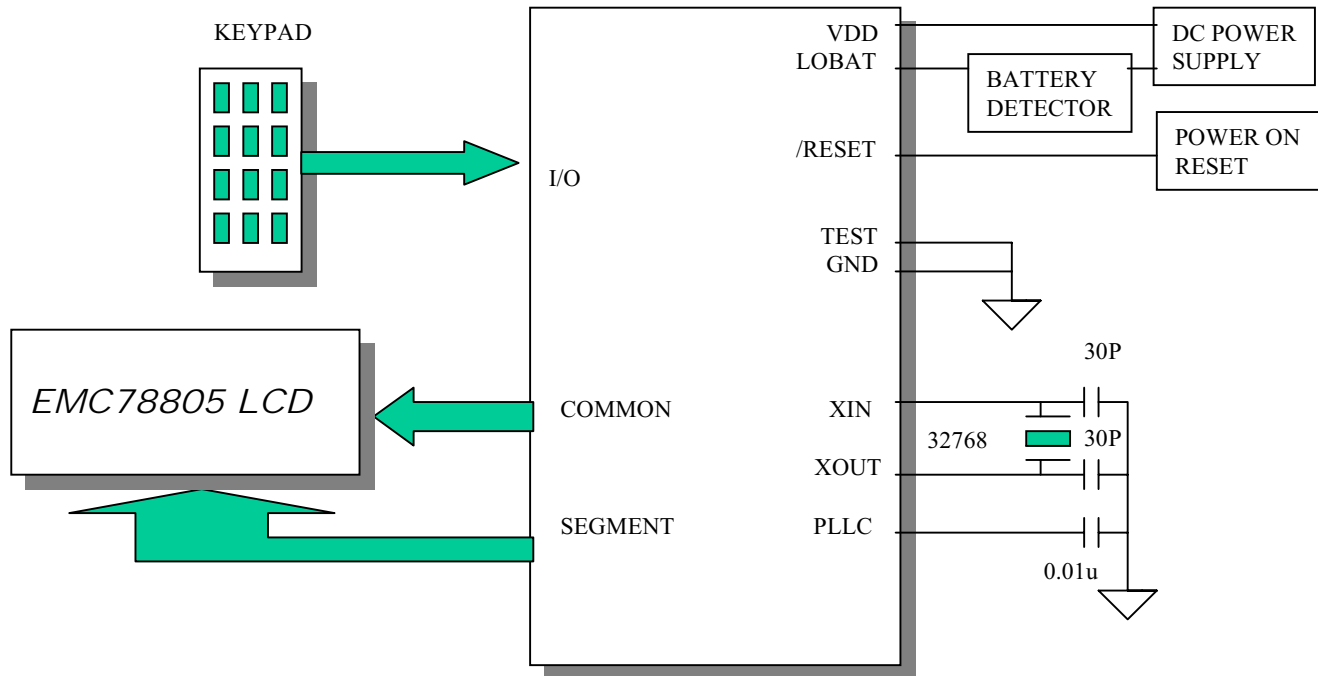

Fig.23 application circuit

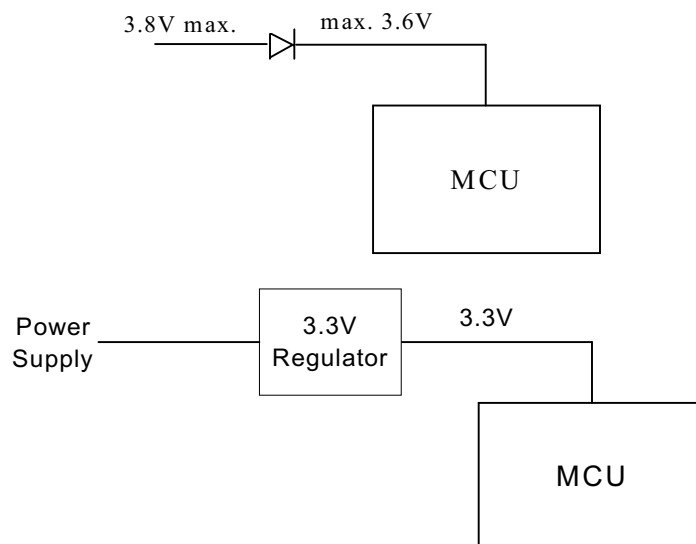

Fig.24 Power Concern in Application