

1. General Description

EM84110 is designed as a Cordless Mouse Decoder which supports 3D, 5 buttons PS/2 Mouse. It requires an external Radio Frequency Module to receive signal and must be applied with EM84100, which is a Cordless Mouse Encoder.

2. Feature

- Compatible with PS/2 mouse.
- Supports 3D, 5 buttons. (Compatible with Microsoft IntelliMouse)
- Effective decoding algorithm for Radio Frequency Transmission.
- Supports up to 8 device Identification Number to avoid the interference from other Radio Frequency devices.
- Supports one sink path for LED to indicate that receiving correct data.

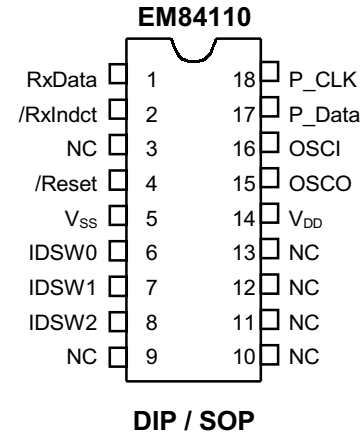

3. Application

- Use as PS/2 3D, 5 buttons Cordless Mouse Decoder.

4. Pin Assignment

Symbol	I/O	Pin	Description
VDD	-	14	5.5V~2.3V Voltage supply.
VSS	-	5	Ground
OSCI	I	16	External crystal input .
OSCO	O	15	Output for crystal oscillator clock.
/Reset	I	4	Reset Pin with Schmitt trigger, It should be pull up by an 180k Ω resistor under normal operation..
IDSW0~IDSW2	I	6,7,8	Device Identification Number Switches input.
RxData	I	1	Radio Frequency transmission data input.
/RxIndct	I	2	This signal indicats that receiving correct data. While receiving correct data, this pin will output "L". It can sink current for a indication LED.
P_Data	I/O	17	PS/2 Data line.
P_Clk	I/O	18	PS/2 Clk line

5. Function Description

1. The protocol of Receiving Data

The input data of EM84110 is a serial signal for cordless transmission. Therefore, noise immunity logic and error detecting logic is applied to the protocol of transmission data.

There is the definition of the protocol below.



(I). Signal definition:

A fixed length of "L" signal followed with a fixed length "H" signal represents a nibble data. The table below showed the different combinations from 0x0 to 0xF. The unit of time is uS.

Data	Signal Components (us)		Data	Signal Components	
	L	H		L	H
0x0	600	400	0x8	600	1000
0x1	600	600	0x9	800	800
0x2	800	400	0xA	1000	400
0x3	800	600	0xB	1000	600
0x4	600	800	0xC	400	1000
0x5	1000	800	0xD	400	800
0x6	800	1000	0xE	400	600
0x7	1000	1000	0xF	400	400

(II).Packet Format:

A packet data is divided into three parts which are PacketID, PacketData and Checkfield.

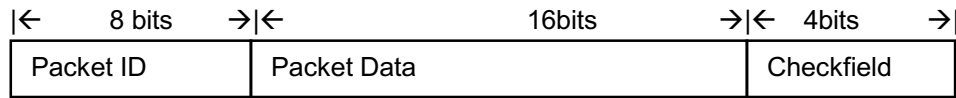

Packet ID

There are 8bits in this field. The first four bits represents the ID of the device and the least four bits represents which kind of Packet data that follows Packet ID field.

There are two kind of Packet data. One contains the value of X-axis counter and Y-axis counter, another contains the state of five buttons and the value of Z-axis counter.

Packet Data

The packet data is 16-bit long. The first byte may be the value of Y-axis counter or Z-axis counter while the least byte may be the value of x-axis counter or the state of five buttons. As the different Packet is transmitting, the contents will be different.

Checkfield

It is used to detect if this packet is destroyed or not.

(III).Begin and End Strob

After a period of idle, the data should be transmitted by following a preamble signal. Besides, there is a start signal in the front of packet and one stop signal in the end of packet.

2. The Operation of Device ID

There are three switches to decid the Device ID of each device. When there is not only one RF device used in a same room, these RF devices may interact. Therefor, the ID switches can provide the protection from the interfrnce of other devices.



3. Legacy PS/2 Mouse Operating:

(A) Operating Mode

There are four operating modes in PS/2 mouse:

a. Reset Mode:

In this mode a self-test is initiated during power-on or by a Reset command. After reset signal, PS/2 mouse will

(a) Send completion code AA & ID code 00.

(b) Set default:

Sampling rate: 100 reports/s

Non-auto-speed

Stream mode

2 dot/count

Disable

b. Stream Mode:

The maximum rate of transfer is the programmed sample rate.

Data report is transmitted if

(a) Switch is pressed

(b) Movement has been detect

c. Remote Mode:

Data is transmitted only in response to a Read Data command.

d. Wrap Mode:

Any byte of data sent by the system, except hex EC (Reset wrap mode) or hex FF (Reset), is returned by EM84110.



(B) PS/2 Mouse Data Report:

- a. In stream mode: A data report is sent at the end of a sample interval.
- b. In remote mode: A data report is sent in response to Read Data command.
- c. Data report format:

Byte	Bit	Description
1	0	Left button status; 1 = pressed
	1	Right button status; 1 = pressed
	2	Middle button status; 1 = pressed
	3	Reserved
	4	X data sign; 1 = negative
	5	Y data sign; 1 = negative
	6	X data overflow; 1 = overflow
	7	Y data overflow; 1 = overflow
2	0-7	X data (D0 - D7)
3	0-7	Y data (D0 - D7)

(C) PS/2 Mouse Data Transmission:

- a. EM84110 generates the clocking signal when sending data to and receiving data from the system.
- b. The system requests EM84110 receive system data output by forcing the DATA line to an inactive level and allowing CLK line to go to an active level.
- c. Data transmission frame:

Bit	Function
1	Start bit (always 0)
2-9	Data bits (D0 - D7)
10	Parity bit (odd parity)
11	Stop bit (always 1)

d. Data Output (data from EM84110 to system):

If CLK is low (inhibit status), data is no transmission. If CLK is high and DATA is low (request-to-send), data is updated. Data is received from the system and no transmission are started by EM84110 until CLK and DATA both high. If CLK and DATA both are high, the transmission is ready. DATA is valid prior to the falling edge of CLK and beyond the rising edge of CLK. During transmission, EM84110 check for line contention by checking for an inactive level on CLK at intervals not to exceed 100u sec. Contention occurs when the system lowers CLK to inhibit EM84110 output after EM84110 has started a transmission. If this occurs before the rising edge of the tenth clock, EM84110 internal store its data in its buffer and returns DATA and CLK to an active level. If the contention does not occur by the tenth clock, the transmission is complete. Following a transmission, the system inhibits EM84110 by holding CLK low until it can service the input or until the system receives a request to send a response from EM84110.

e. Data Input (from system to EM84110):

The System first checks if EM84110 is transmitting data. If EM84110 is transmitting, the system can override the output forcing CLK to an inactive level prior to the tenth



clock. If EM84110 transmission is beyond the tenth clock, the system receives the data. If EM84110 is not transmitting or if the system choose to override the output, the system force CLK to an inactive level for a period of not less than 100u sec while preparing for output. When the system is ready to output start bit (0), it allows CLK go to active level. If request-to-send is detected, EM84110 clocks 11 bits. Following the tenth clock, EM84110 checks for an active level on the DATA line, and if found, force DATA low, and clock once more. If occurs framing error, EM84110continue to clock until DATA is high, then clocks the line control bit and request a Resend.

When the system sends out a command or data transmission that requires a response, the system waits for EM84110 to response before sending its next output.



(D) PS/2 Mouse Error Handling:

- a. A Resend command (FE) following receipt of an invalid input or any input with incorrect polarity.
- b. If two invalid inputs are received in succession, an error code of hex (FC) is send to the system.
- c. The counter accumulators are cleared after receiving any command except "Resend".
- d. EM84110 receives a Resend command (FE), it transmits its last packet of data.
- e. In the stream mode "Resend" is received by EM84110 following a 3-byte data packet transmission to the system. EM84110 resend the 3-byte data packet prior to clearing the counter.
- f. A response is sent within 25 ms if
 - (a) The system requires a response
 - (b) An error is detected in the transmission
- g. If EM84110 is in the stream mode:
 - (a) The system disables EM84110 before issuing any command requiring a response.
 - (b) When a command requiring a response is issued by the system, another command should not be issue until either the response is received or 25ms has passed.



(E) PS/2 Mouse Commands Description:

There are 16 valid commands that transmit between the system and EM84110. The "FA" code is always the first response to any valid input received from the system other than a Set Wrap Mode or Resend command.

The following table lists the commands:

Hex Code	Command	Echo code
FF	Reset	FA,AA,00
FE	Resend	XX,(XX,XX)
F6	Set Default	FA
F5	Disable	FA
F4	Enable	FA
F3,XX	Set Sampling Rate	FA,FA
F2	Read Device Type	FA,00
F0	Set Remote Mode	FA
EE	Set Wrap Mode	FA
EC	Reset Wrap Mode	FA
EB	Read Data	FA,XX,XX,XX
EA	Set Stream Mode	FA
E9	Status Request	FA,XX,XX,XX
E8,XX	Set Resolution	FA,FA
E7	Set Auto-speed	FA
E6	Reset Auto-speed	FA

The following describes valid commands:

a. Reset (FF)

EM84110 operation:

- (a) Completion the reset.
- (b) Transmit FA, AA, 00 to the system.
- (c) Set default:
Sampling rate: 100 reports/s
Non auto-speed
Stream mode
2 dot/count
Disable

b. Resend (FE)

- (a) Any time EM84110 receives an invalid command, it returns a Resend command to the system.
- (b) When EM84110 receives a Resend command, it retransmits its last packet of data. If the last packet was a Resend command, it transmits the packet just prior to the Resend command.
- (c) In stream mode, if a Resend command is received by EM84110 immediately following a 3-byte data packet transmission to the system.

c. Set Default (F6)

The command reinitializes all conditions to the power-on defaults.

d. Disable (F5)

This command is used in the stream mode to stop transmissions from EM84110.



e. Enable (F4)
Begins transmissions, if in stream mode.

f. Set Sampling Rate (F3, XX)
In the stream mode, this command set the sampling rate to the value indicated by byte hex XX, shown in following:

Second byte XX	Sample Rate
0A	10/sec
14	20/sec
28	40/sec
3c	60/sec
50	80/sec
64	100/sec
C9	200/sec

g. Read Device Type (F2)
EM84110 always echoes " FA, 00" following this command.

h. Set Remote Mode (F0)
Data values are reported only in response to a Read Data command.

i. Set Wrap Mode (EE)
Wrap mode remains until Reset (FF) or Reset Wrap Mode (EC) is received.

j. Reset Wrap Mode (EC)
EM84110 returns to the previous mode of operation after receiving this command.

k. Read Data (EB)
This command is executed in either remote or stream mode. The data is transmitted even if there has been no movement since the last report or the button status is unchanged. Following a Read Data command, the registers are cleared after a data transmission.

l. Set Stream Mode (EA)
This command sets EM84110 in stream mode.

m. Status Request (E9)
When this command is issued by the system, EM84110 responds with a 3-byte status report as follows:

Byte	Bit	Description
1	0	1 = Right button pressed
	1	1 = Middle button pressed
	2	1 = Left button pressed
	3	Reserved
	4	0 = Normal speed, 1 = Auto-speed
	5	0 = Disabled, 1 = Enabled
	6	0 = Stream mode, 1 = Remote mode
	7	Reserved
2	0-7	Current resolution setting (D0 - D7)
3	0-7	Current sampling rate (D0 - D7)

n. Set Resolution (E8, XX)



EM84110 provides four resolutions selected by the second byte of this command as follows:

Second Byte XX	Resolution
00	8 dot/count
01	4 dot/count
02	2 dot/count
03	1 dot/count

o. Set Auto-speed (E7)

At the end of a sample interval in the stream mode, the current X and Y data values are converted new values. The sign bits are not involved in this conversion. The conversion is only in stream mode. The relationship between the input and output count follows:

Input	Output
0	0
1	1
2	1
3	3
4	6
5	9
N(>=6)	2.0*N

p. Reset Auto-speed (E6)

This command restores normal speed.



(III). Microsoft PS/2 Scrolling Mouse Mode:

(A) Entering procedure: Except in WRAP mode, while EM84110 received the following consecutive command.

- a. F3 C8 ---- set sampling rate 200/sec
- b. F3 64 ---- set sampling rate 100/sec
- c. F3 50 ---- set sampling rate 80/sec

(B) Operating:

- a. All of the commands in legacy mode still are valid.
- b. The ID code of read device type command (F2) will changed from "00" to be "03".
- c. Data report will be four bytes format:

Byte	Bit	Description
1	0	Left button status; 1 = pressed
	1	Right button status; 1 = pressed
	2	Middle button status; 1 = pressed
	3	Reserved
	4	X data sign; 1 = negative
	5	Y data sign; 1 = negative
	6	X data overflow; 1 = overflow
	7	Y data overflow; 1 = overflow
2	0-7	X data (D0 - D7)
3	0-7	Y data (D0 - D7)
4	0-7	Z data (D0 - D7)

(C) Exiting Microsoft Scrolling Mode:

There are two ways to exit:

- a. Power off.
- b. Reset command (FF).



(IV). Microsoft PS/2 IntelliMouse Mode:

(A) Entering procedure: Except in WRAP mode, while EM84110 received the following consecutive command.

- a. F3 C8 ---- set sampling rate 200/sec
- b. F3 C8 ---- set sampling rate 200/sec
- c. F3 50 ---- set sampling rate 80/sec

(B) Operating:

- a. All of the commands in legacy mode still are valid.
- b. The ID code of read device type command (F2) will be changed from "00" to be "04".
- c. Data report will be four bytes format:

Byte	Bit	Description
1	0	Left button status; 1 = pressed
	1	Right button status; 1 = pressed
	2	Middle button status; 1 = pressed
	3	Reserved
	4	X data sign; 1 = negative
	5	Y data sign; 1 = negative
	6	X data overflow; 1 = overflow
	7	Y data overflow; 1 = overflow
2	0-7	X data (D0 – D7)
3	0-7	Y data (D0 – D7)
4	0-3	Z data (D0 – D3)
	4	PreviousPage button status; 1= pressed
	5	NextPage button status; 1=pressed
	6-7	Reserved

(C) Exiting Microsoft IntelliMouse Mode:

There are two ways to exit:

- a. Power off.
- b. Reset command (FF).

6. Application circuit

PS/2 Cordless Mouse Receiving Data Box

