



EN27C512 512KBIT EPROM (64K x 8)

FEATURES

- Fast Read Access Time: -45, -55, -70, and -90ns
- Single 5V Power Supply
- Programming Voltage +12.75V
- QuikRite™ Programming Algorithm
- Typical programming time 20µs
- Low Power CMOS Operation
- 1µA Standby (Typical)
- 30mA Operation (Max.)
- CMOS- and TTL-Compatible I/O
- High-Reliability CMOS Technology
- Latch-Up Immunity to 100mA from -1V to V_{CC} + 1V
- Two-Line Control (\overline{OE} & \overline{CE})
- Standard Product Identification Code
- JEDEC Standard Pinout
 - 28-pin PDIP
 - 32-pin PLCC
 - 28-pin TSOP (Type 1)
- Commercial and Industrial Temperature Ranges

GENERAL DESCRIPTION

The EN27C512 is a low-power 512Kbit, 5V-only one-time-programmable (OTP) read-only memory (EPROM). Organized into 64K words with 8 bits per word, it features QuikRite™ single-address location programming, typically at 20µs per byte. Any byte can be accessed in less than 45ns, eliminating the need for WAIT states in high-performance microprocessor systems. The EN27C512 has separate Output Enable (\overline{OE}) and Chip Enable (\overline{CE}) controls which eliminate bus contention issues.

FIGURE 1. PDIP

Pin Name	Function
A0-A15	Addresses
DQ0-DQ7	Outputs
\overline{CE}	Chip Enable
\overline{OE}	Output Enable
NC	No Connect

PDIP Top View

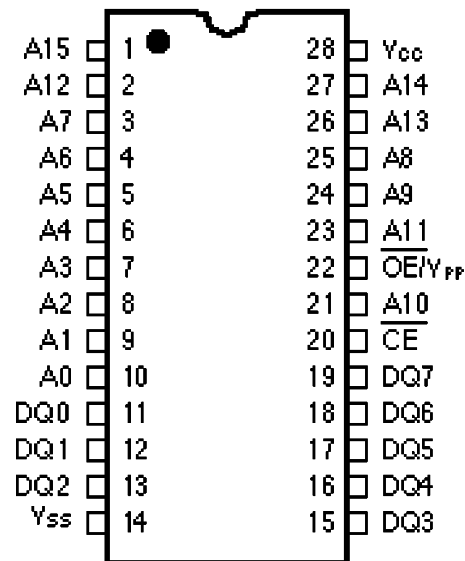
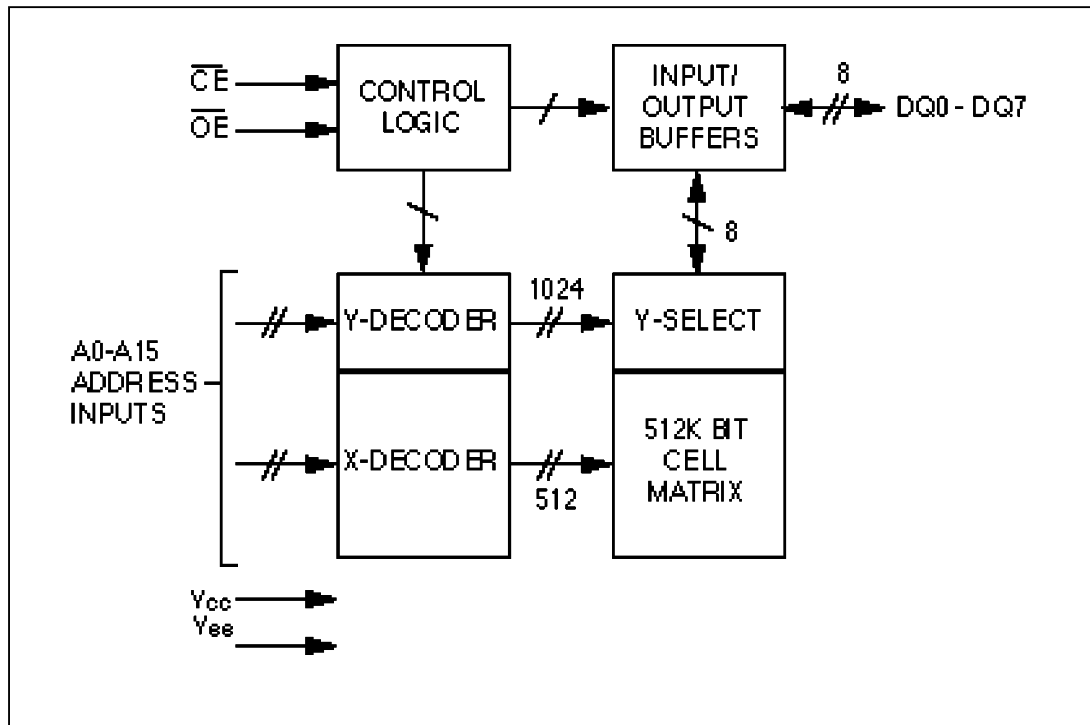

FIGURE 4. BLOCK DIAGRAM

FUNCTIONAL DESCRIPTION

THE QUIKRITE™ PROGRAMMING OF THE EN27C512

When the EN27C512 is delivered, the chip has all 512K bits in the “ONE”, or HIGH state. “ZEROS” are loaded into the EN27C512 through the procedure of programming.

The programming mode is entered when $12.75 \pm 0.25V$ is applied to the \overline{OE}/V_{PP} pin and \overline{CE} is at V_{IL} . For programming, the data to be programmed is applied with 8 bits in parallel to the data pins.

The QUIKRITE™ programming flowchart in Figure 5 shows Eon’s interactive programming algorithm. The interactive algorithm reduces programming time by using 20 μs to 100 μs programming pulses and giving each address only as many pulses as is necessary in order to reliably program the data. After each pulse is applied to a given address, the data in that address is verified. If the data is not verified, additional pulses are given until it is verified or until the maximum number of pulses is reached. This process is repeated while sequencing through each address of the EN27C512. This part of the programming algorithm is done at $V_{CC} = 6.25V$ to assure that each EPROM bit is programmed to a sufficiently high threshold voltage. This ensures that all bits have sufficient margin. After the final address is completed, the entire EPROM memory is read at $V_{CC} = 5.25 \pm 0.25V$ to verify the entire memory.



PROGRAM INHIBIT MODE

Programming of multiple EN27C512 in parallel with different data is also easily accomplished by using the Program Inhibit Mode. Except for \overline{CE} , all like inputs of the parallel EN27C512 may be common. A TTL low-level program pulse applied to an EN27C512 \overline{CE} input with $\overline{OE}/V_{PP} = 12.75 \pm 0.25V$ will program that EN27C512. A high-level \overline{CE} input inhibits the other EN27C512 from being programmed.

PROGRAM VERIFY MODE

Verification should be performed on the programmed bits to determining that they were correctly programmed. The verification should be performed with \overline{OE}/V_{PP} and \overline{CE} at V_{IL} . Data should be verified at t_{DV} after the falling edge of \overline{CE} .

AUTO PRODUCT IDENTIFICATION

The Auto Product Identification mode allows the reading out of a binary code from an EPROM that will identify its manufacturer and type. This mode is intended for use by programming equipment for the purpose of automatically matching the device to be programmed with its corresponding programming algorithm. This mode is functional in the $25^{\circ}C \pm 5^{\circ}C$ ambient temperature range that is required when programming the EN27C512.

To activate this mode, the programming equipment must force $12.0V \pm 0.5V$ on address line A9 of the EN27C512. Two identifier bytes may then be sequenced from the device outputs by toggling address line A0 from V_{IL} to V_{IH} , when $A1 = V_{IH}$. All other address lines must be held at V_{IL} during Auto Product Identification mode.

Byte 0 ($A0 = V_{IL}$) represents the manufacturer code, and byte 1 ($A0 = V_{IH}$), the device code. For the EN27C512, these two identifiers bytes are given in the Mode Select Table. All identifiers for manufacturer and device codes will possess odd parity, with the MSB (DQ7) defined as the parity bit. When $A1 = V_{IL}$, the EN27C512 will read out the binary code of 7F, continuation code, to signify the unavailability of manufacturer ID codes.



READ MODE

The EN27C512 has two control functions, both of which must be logically satisfied in order to obtain data at the outputs. Chip Enable (\overline{CE}) is the power control and should be used for device selection. Output Enable (\overline{OE}) is the output control and should be used to gate data to the output pins, independent of device selection. Assuming that addresses are stable, address access time (t_{ACC}) is equal to the delay from \overline{CE} to output (t_{CE}). Data is available at the outputs (t_{OE}) after the falling edge of \overline{OE} , assuming the \overline{CE} has been LOW and addresses have been stable for at least $t_{ACC} - t_{OE}$.

STANDBY MODE

The EN27C512 has CMOS standby mode which reduces the maximum V_{CC} current to 20 μ A. It is placed in CMOS standby when \overline{CE} is at $V_{CC} \pm 0.3$ V. The EN27C512 also has a TTL-standby mode which reduces the maximum V_{CC} current to 1.0 mA. It is placed in TTL-standby when \overline{CE} is at V_{IH} . When in standby mode, the outputs are in a high-impedance state, independent of the \overline{OE} input.

TWO-LINE OUTPUT CONTROL FUNCTION

To accommodate multiple memory connections, a two-line control function is provided to allow for:

1. Low memory power dissipation,
2. Assurance that output bus contention will not occur.

It is recommended that \overline{CE} be decoded and used as the primary device-selection function, while \overline{OE} be made a common connection to all devices in the array and connected to the READ line from the system control bus. This assures that all deselected memory devices are in their low-power standby mode and that the output pins are only active when data is desired from a particular memory device.

SYSTEM CONSIDERATIONS

During the switch between active and standby conditions, transient current peaks are produced on the rising and falling edges of Chip Enable. The magnitude of these transient current peaks is dependent on the output capacitance loading of the device. At a minimum, a 0.1 μ F ceramic capacitor (high frequency, low inherent inductance) should be used on each device between V_{CC} and V_{SS} to minimize transient effects. In addition, to overcome the voltage drop caused by the inductive effects of the printed circuit board traces on EPROM arrays, a 4.7 μ F bulk electrolytic capacitor should be used between V_{CC} and V_{SS} for each eight devices. The location of the capacitor should be close to where the power supply is connected to the array.

**MODE SELECT TAB**

Mode	$\overline{\text{CE}}$	$\overline{\text{OE}}/V_{\text{PP}}$	A0	A9	Output
Read	V_{IL}	V_{IL}	X	X	D_{OUT}
Output Disable	V_{IL}	V_{IH}	X	X	High Z
Standby (TTL)	V_{IH}	X	X	X	High Z
Standby (CMOS)	$V_{\text{CC}} \pm 0.3\text{V}$	X	X	X	High Z
Program ⁽⁴⁾	V_{IL}	V_{PP}	X	X	D_{IN}
Program Verify	V_{IL}	V_{IL}	X	X	D_{OUT}
Program Inhibit	V_{IH}	V_{PP}	X	X	High Z
Manufacturer Code ⁽³⁾	V_{IL}	V_{IL}	V_{IL}	$V_{\text{H}}^{(1)}$	1C
Device Code ⁽³⁾	V_{IL}	V_{IL}	V_{IH}	$V_{\text{H}}^{(1)}$	83

NOTES:

- 1) $V_{\text{H}} = 12.0\text{V} \pm 0.5\text{V}$
- 2) X = Either V_{IH} or V_{IL}
- 3) For Manufacturer Code and Device Code, $A1 = V_{\text{IH}}$
When $A1 = V_{\text{IL}}$, both codes will read 7F
- 4) See DC Programming Characteristics for V_{PP} voltage during programming

EON'S STANDARD PRODUCT IDENTIFICATION CODE

Code	Pins										Hex Data
	A0	A1	DQ7	DQ6	DQ5	DQ4	DQ3	DQ2	DQ1	DQ0	
Manufacturer	0	1	0	0	0	1	1	1	0	0	1C
Device Type	1	1	1	0	0	0	0	0	1	1	83
Continuation	0	0	0	1	1	1	1	1	1	1	7F
	1	0	0	1	1	1	1	1	1	1	7F

FIGURE 5. QUIKRITE™ PROGRAMMING FLOW CHART

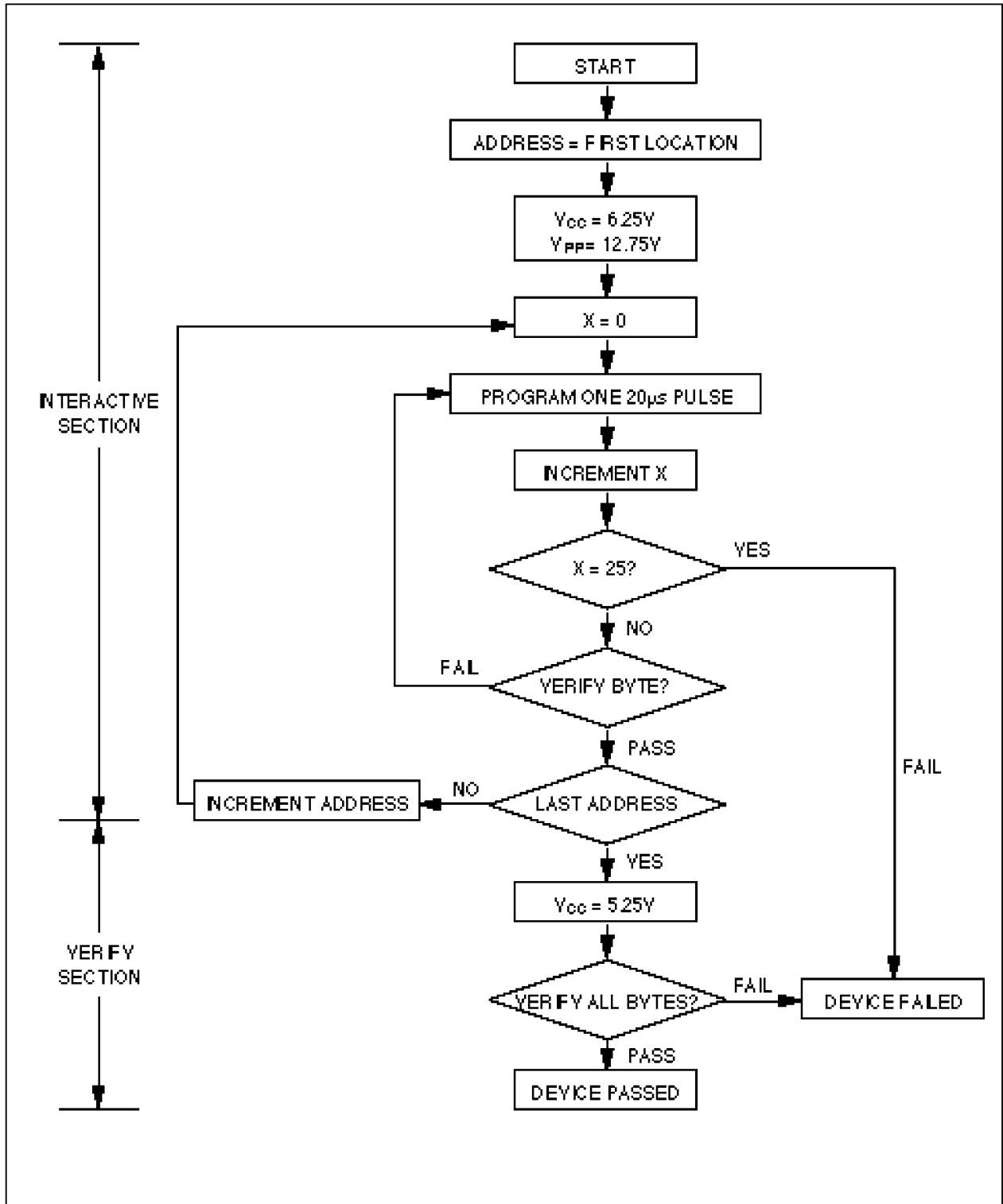

NOTE 1: Either 100µs or 20µs pulse.

**ABSOLUTE MAXIMUM RATINGS**

Storage Temperature	-65 ° C to +125 ° C
Ambient Temperature with Power Applied	-40 ° C to +85 ° C
Voltage with Respect to V_{SS}	
All pins except A9, V _{PP} , V _{CC}	-0.6V to V _{CC} + 0.5V
A9, V _{PP}	-0.6V to +13.5V
V _{CC}	-0.6V to +7.0V

OPERATING RANGES

Commercial (C)	
Case Temperature(T _c)	0 ° C to +70 ° C
Industrial (I)	
Case Temperature(T _c)	-40 ° C to +85 ° C
Supply READ Voltages	+4.50V to +5.5V
(Functionality is guaranteed between these limits)	

Stresses above those shown above may cause permanent damage to the device. This is a stress rating only and operation above these specifications for extended periods may affect device reliability. Operation outside the "OPERATING RANGES" shown above voids any and all warranty provisions.

DC CHARACTERISTICS FOR READ OPERATION

Symbol	Parameter	Min.	Max.	Unit	Conditions
V _{OH}	Output High Voltage	2.4		V	I _{OH} = -0.4mA
V _{OL}	Output Low Voltage		0.45	V	I _{OL} = 2.1mA
V _{IH}	Input High Voltage	2.0	V _{CC} +0.5	V	
V _{IL}	Input Low Voltage	-0.3	0.8	V	
I _{LI}	Input Leakage Current	-5	5	μA	V _{IN} = 0 to 5.5V
I _{LO}	Output Leakage Current	-10	10	μA	V _{OUT} = 0 to 5.5V
I _{CC3}	V _{CC} Power -Down Current		10	μA	$\overline{CE} = V_{CC} \pm 0.3V$
I _{CC2}	V _{CC} Standby Current		1.0	mA	$\overline{CE} = V_{IH}$
I _{CC1}	V _{CC} Active Current		30	mA	$\overline{CE} = V_{IL}$, f=5MHz, I _{OUT} = 0mA
I _{PP}	V _{PP} Supply Current Read		100	μA	$\overline{CE} = \overline{OE} = V_{IL}$, V _{PP} = 5.5V

CAPACITANCE

Symbol	Parameter	Typ.	Max.	Unit	Conditions
C _{IN}	Input Capacitance	8	12	pF	V _{IN} = 0V
C _{OUT}	Output Capacitance	8	12	pF	V _{OUT} = 0V
C _{VPP}	V _{PP} Capacitance	18	25	pF	V _{PP} = 0V



AC CHARACTERISTICS FOR READ OPERATION

Symbol	Parameter	Condition	EN27C512				Unit				
			-45		-55			-70		-90	
			Min	Max	Min	Max	Min	Max	Min	Max	
tACC (3)	Address to Output Delay	$\overline{CE} = \overline{OE} = V_{IL}$		45		55		70		90	ns
tCE (2)	\overline{CE} to Output Delay	$\overline{OE} = V_{IL}$		45		55		70		90	ns
tOE (2, 3)	\overline{OE} to Output Delay	$\overline{OE} = V_{IL}$		25		25		30		35	ns
tDF (4, 5)	\overline{OE} or \overline{CE} High to Output Float, whichever occurred first			20		20		25		25	ns
tOH	Output Hold from Address, \overline{CE} or \overline{OE} , whichever occurred first		0		0		0		0		ns

FIGURE 6. AC WAVEFORMS FOR READ OPERATION

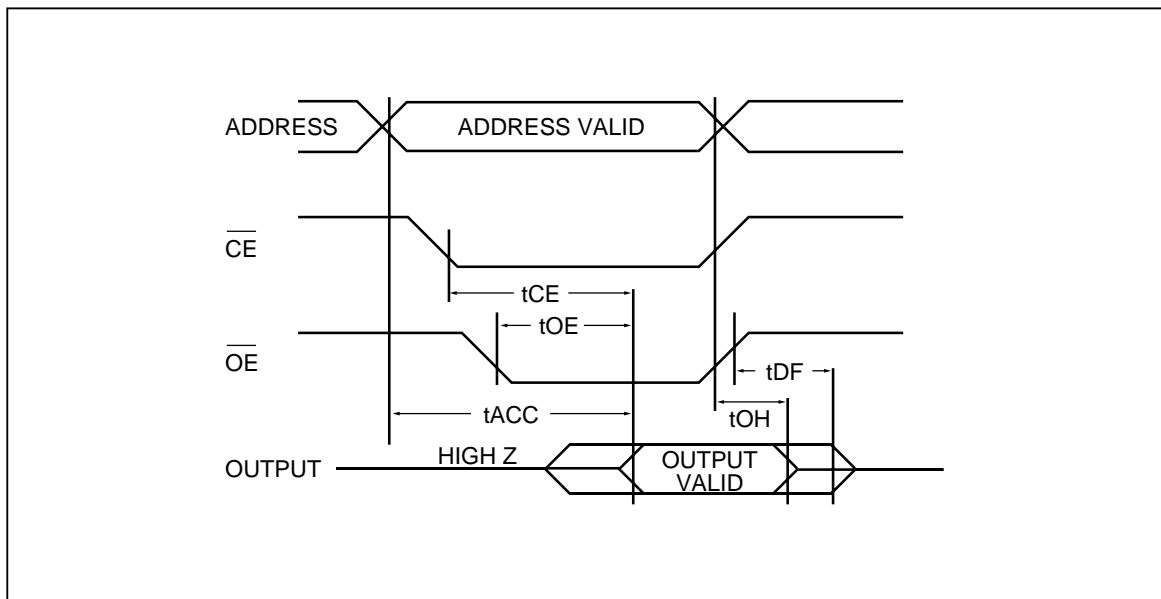
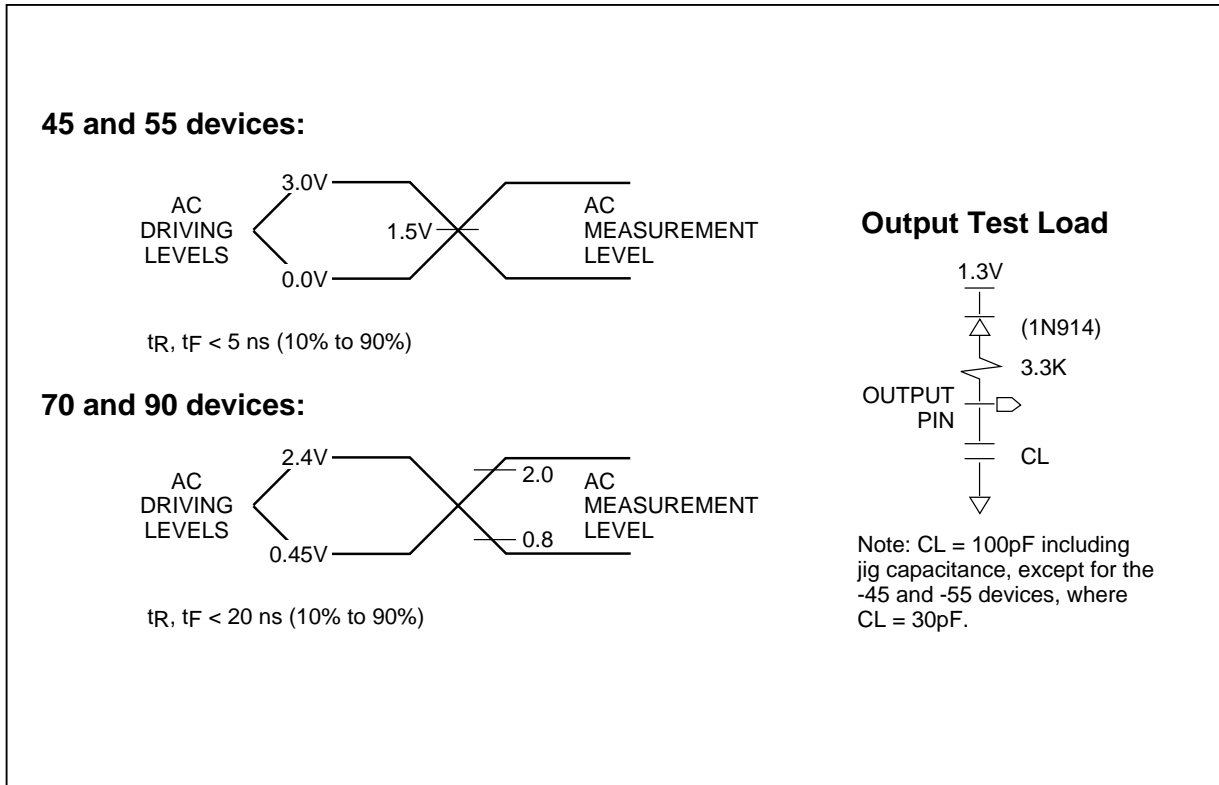
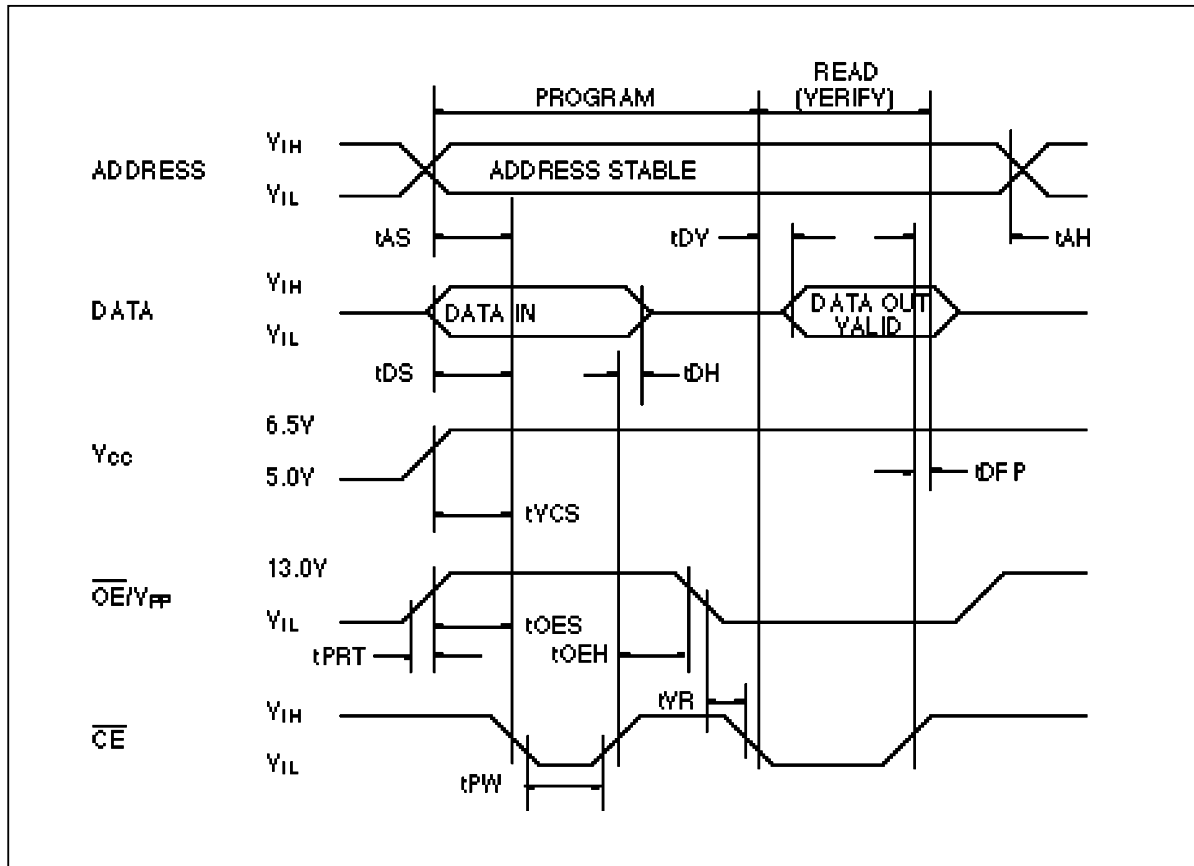

FIGURE 7. OUTPUT TEST WAVEFORMS AND MEASUREMENTS

DC PROGRAMMING CHARACTERISTICS

Symbol	Parameter	Test Conditions	Limits		Units
			Min.	Max	
I_{LI}	Input Load Current	$V_{IN} = V_{IL}, V_{IH}$		5.0	μA
V_{IL}	Input Low Level		-0.5	0.8	V
V_{IH}	Input High Level		$0.7 V_{CC}$	$V_{CC} + 0.5$	V
V_{OL}	Output Low Voltage	$I_{OL} = 2.1 \text{ mA}$		0.45	V
V_{OH}	Output High Voltage	$I_{OH} = -400 \mu\text{A}$	2.4		V
I_{CC2}	V_{CC} Supply Current (Program and Verify)			40	mA
I_{PP2}	V_{PP} Supply Current	$\overline{CE} = \overline{PGM} = V_{IL}$		10	mA
V_{ID}	A9 Product Identification Voltage		11.5	12.5	V

FIGURE 8. PROGRAMMING WAVEFORMS

**SWITCHING PROGRAMMING CHARACTERISTICS** $(T_A = +25^\circ\text{C} \pm 5^\circ\text{C})$

PARAMETER SYMBOL	PARAMETER DESCRIPTION	Min.	Max	Units
t_{AS}	Address Setup Time	2		μs
t_{OES}	\overline{OE}/V_{PP} Setup Time	2		μs
t_{OEH}	\overline{OE}/V_{PP} Hold Time	2		μs
t_{DS}	Data Setup Time	2		μs
t_{AH}	Address Hold Time	0		μs
t_{DH}	Data Hold Time	2		μs
t_{DFP}	Output Enable to Output Float Delay	0	130	ns
t_{PW}	PGM Program Pulse Width	20	105	μs
t_{VCS}	V_{CC} Setup Time	2		μs
t_{DV}	Data Valid from \overline{CE}		150	ns
t_{VR}	\overline{OE}/V_{PP} Hold Time	2		μs

ORDERING INFORMATION