

CLASS D AUDIO AMPLIFIER MODULE

ECM-300H 300W RMS CLASS D AUDIO AMPLIFIER MODULE

FEATURES

- HIGH POWER: 300W RMS¹
- HIGH EFFICIENCY >90%
- HIGH SWITCHING FREQUENCY: 450KHZ.
- LOW DISTORTION: <0.3% THD OPEN LOOP
- SIMPLE POWER SUPPLY REQUIREMENT²
- THERMALLY EFFICIENT PACKAGE:
 - INTEGRAL HEATSINK
 - NO COOLING FANS REQUIRED
- LOW NOISE: NOISE FLOOR typ. 85dB DOWN³
- EMC SCREEN INTEGRAL TO PACKAGE
- OVER TEMPERATURE PROTECTION OPTION⁴
- OVER CURRENT PROTECTION OPTION⁴
 - PULSE BY PULSE
- LOW QUIESCENT CURRENT - MUTE FACILITY
- DRIVES A 16Ω, 8Ω AND 4Ω SPEAKER⁵
- SLAVE MODULES CAN BE LINKED TO BOOST DRIVE CAPABILITY (WITH MASTER OPTION)
- OTHER POWER OPTIONS AVAILABLE¹
- LOW COST
- LIGHTWEIGHT
- CUSTOM AMPLIFIER DESIGNS AVAILABLE

NOTES

- 1) Other power options include 1000W, 800W, 600W, 150W and 50W. Alternately, custom power levels can be produced.
- 2) Companion PSU unit will be available early 2001
- 3) Assumes minimisation of external noise coupling and measured in audio band only.
- 4) Contact Profusion for more details of these options
- 5) 2Ω speaker variant available

APPLICATIONS

- PROFESSIONAL AUDIO POWER AMPLIFIER
- ACTIVE SPEAKER SYSTEMS
- ACTIVE SONAR SYSTEMS
- NOISE CANCELLATION SYSTEMS
- MOTOR / MAGNET DRIVE MODULES
- POWER CONVERSION
- UPS - SINE WAVE INVERTER

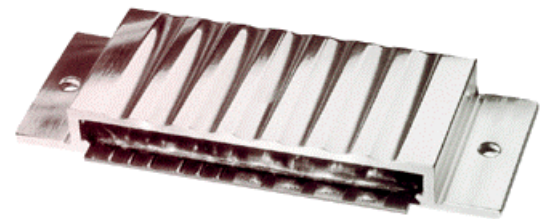

DESCRIPTION

The ECM-300H is a complete professional audio power amplifier module. The module contains power transistor drive electronics, control, and protection circuitry. Only a power supply, decoupling capacitors and output filter (optional) must be added to produce a stand alone professional audio amplifier. The module is optimised to drive a 4Ω load (16Ω, 8Ω and 2Ω optimised versions are available). Modules can be ganged together to produce a stereo amplifier.

For higher power applications the ECM-600H module should be considered.

Please contact Profusion for a confidential discussion of your requirements and further application information.

SPECIFICATIONS

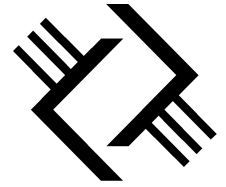

Absolute maximum ratings

Rail voltage, V_{RS}	60 V
Control voltages V_L	± 18 V
Total current into V_L	150 mA
Operating free air temperature, T_A	-10°C to 40°C
Storage temperature range, T_{stg}	-40°C to 70°C
PCB solder pad temperature for 60 secs	260°C

Stresses beyond those listed under absolute maximum ratings may cause permanent damage to the device. These are stress ratings only and functional operation of the device at these or any other conditions beyond those indicated "recommended operating conditions" is not implied.

Recommended operating conditions

	MIN	TYP	MAX	UNIT
RAIL VOLTAGE, V_{RS}	0	49	55	V
POWER SUPPLY VOLTAGES, $\pm V_L$	9.5	10	12	V
AUDIO INPUT, S_2	0	± 1	± 1.09	V _{p-p}
MODULATION FACTOR	0	0.9	0.98	
OPERATING FREE AIR TEMPERATURE, T_A	10		60	$^{\circ}\text{C}$

Electrical characteristics at a free air temperature of 25°C

PARAMETER	NOTES/TEST CONDITIONS	VALUE			UNIT
		$V_{RS} = 50$ V			
		MIN	TYP	MAX	
S_3 ENABLE INPUT (Other input options available)	LEAVE UNCONNECTED OR CONNECT TO 0V TO ENABLE	4.75	5	5.25	V _{p-p}
R_{EN} ENABLE INPUT IMPEDANCE			10		K Ω
R_{IN} AUDIO INPUT IMPEDANCE (Other input options available)			7.3		K Ω
I_L POWER SUPPLY CURRENT	$R_L = 4\Omega$		100	150	mA
I_{RS} POWER RAIL CURRENT	$R_L = 4\Omega$		6		A
P_{RR} ALLOWABLE POWER RAIL RIPPLE	SEPARATE POWER SUPPLY MODULE AVAILABLE			1	%
r_o OUTPUT RESISTANCE	$R_L = 4\Omega$			100	m Ω
SNR SIGNAL TO NOISE RATIO	$R_L = 4\Omega$ (in audio band)		-85		dB
f_{sw} SWITCHING FREQUENCY (Provisional)			450		KHz
t_{PD} PROPAGATION DELAY (POWER OUTPUT STAGE)	$R_L = 4\Omega$		150		ns

OUTPUT POWER and EFFICIENCY

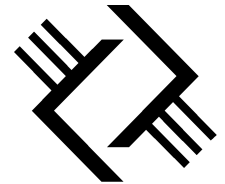

Total coupled power

The *total coupled power* from the input of the amplifier to the load is determined by three parameters. These are:

1. The input signal level with respect to the maximum input level (*Modulation factor*)
2. The *Inherent efficiency* of the amplifier module.
3. The attenuation of the audio signal by the output filter (*Filter attenuation*).

Modulation Factor

The maximum input audio signal level for the amplifier is normally $\pm 1V$ peak to peak. For signal levels greater than this range the amplifier will 'clip' which will produce a distorted signal. Driving the amplifier into clip will not damage the module but will severely degrade the replication of the audio signal and can in some cases damage the loudspeakers. At $\pm 1V$ peak to peak the *modulation factor* is 0.9 i.e. the input signal is at 90% of the full input range. If the input signal magnitude is well controlled, higher *modulation factors* can be used. In practice 0.98 modulation factor ($\pm 1.09V$ peak to peak) should be considered the absolute maximum and 0.95 ($\pm 1.05V$ peak to peak) should be adopted in applications where maximum power coupled to the loudspeaker load is desirable. If the amplifier module is to be used at high modulation factors we recommend using an anti-clip circuit. This circuitry can either be added by the user external to the module or selected anti-clip options can be incorporated in to the package. For the various options, please see the later section or contact Profusion.

Inherent Efficiency

The amplifier modules are tested for the *inherent efficiency* by measuring the power coupled into the defined load (non-inductive dummy load). To calculate the *inherent efficiency*, the differential voltage across the load is measured for the defined rail voltage. The control of the power output from the amplifier module is achieved by varying the rail voltage. At a given rail voltage the maximum *theoretical output power* is given by the chart opposite.

For example, if the rail voltage is 20V and the differential voltage across the load is measured at 38V, the power into a 4Ω load would be:

$$\text{Measured power} = (38/2)^2 / (4 * 2) \text{ or } 45W_{rms}$$

Rail voltage versus maximum power into a pure 4 ohm pure resistive load

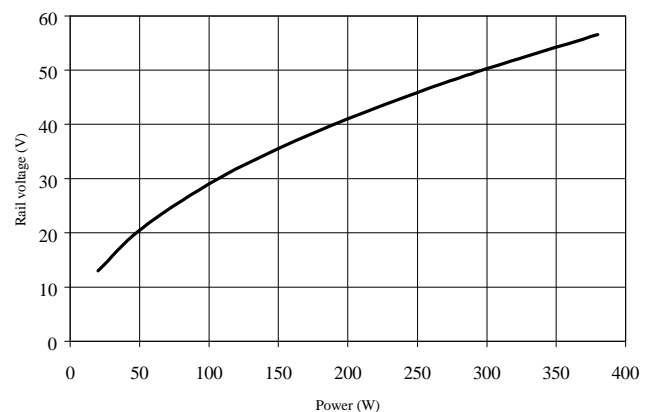

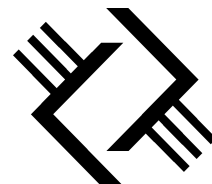

From the chart above:

Maximum *theoretical output power* at 20V = 50Wrms.

Then, the *Inherent Efficiency* of the amplifier module is 90%.

In practice, the quality of the amplifier terminations can affect the *Inherent Efficiency*, for maximum efficiency the power connections (Rail voltage, Output terminals and the power ground) should be made with soldered connections. If losses in the wiring to the load are minimised *Inherent Efficiencies* of 95% are achievable.

Filter Attenuation

The direct output from the amplifier module is a pulse width modulated signal. The underlying audio signal has been mixed inside the amplifier with a switching frequency at 450KHz. It is possible to connect the amplifier output directly to a loudspeaker and produce acceptable performance. However, if the speaker is remote from the amplifier or sensitive high frequency tweeters are being used it is advisable to filter out the switching frequency.

Design of a high efficiency, flat passband filter with maximum attenuation of the switching frequency is not trivial. Hence, the audio amplifier output filter requirements are minimum attenuation and distortion in the passband from 20Hz to 20KHz. Thereafter maximum attenuation at the switching frequency. The load for the filter is a 4Ω loudspeaker which could vary dynamically from 1Ω to 8Ω. If a simple LC lowpass filter is used to minimise the attenuation in the audio band of frequencies, the attenuation of the modulation fundamental frequency will be typically 25dB. In addition, any gain peaking introduced by the simple filter will distort the upper frequency ranges of the audio band and introduce instabilities. In some applications this simple filter could be acceptable, However, for more demanding applications, a filter that provides greater than 40dB attenuation of the switching frequency, whilst providing a flat audio passband with less than 0.5dB attenuation is available. For more details of alternative filter combinations please contact Profusion.

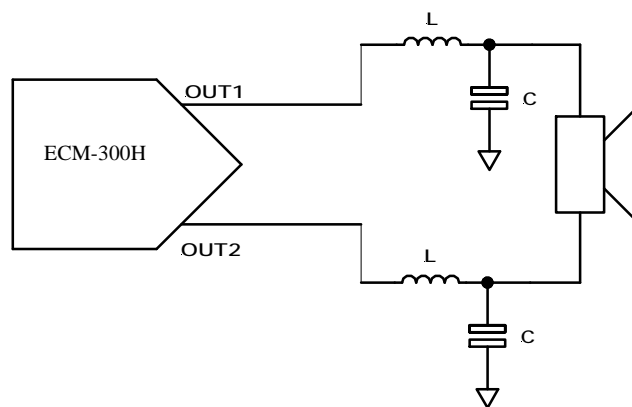
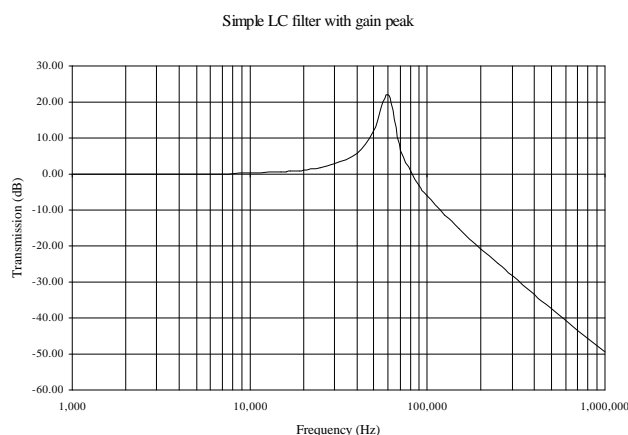

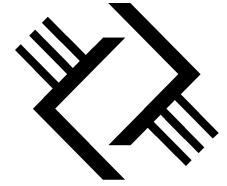

When calculating the *total coupled power* the combined effects of the above parameters must be considered. One final parameter that will affect the total coupled power that is within the control of the user is the wiring resistance. It is important to minimise the resistance of the cableforms from the amplifier to the filter (if used) and from the filter to the loudspeaker. For example, 0.1Ω of cable resistance will form a potential divider with the speaker load.

For a 4Ω load the power loss due to this wiring resistance is 0.4dB.

If the *total coupled power* into the load is expressed in decibels of loss (excluding wiring resistance) then:

$$\text{Total coupled power} = \text{theoretic output power} + \text{modulation factor} + \text{inherent efficiency} + \text{Filter attenuation}$$

Using our patented filter design, and maximum *modulation factor*, it is possible to achieve *total coupled power* figures of 85% or -1.4dB attenuation in the audio pass band.

To minimise quiescent power dissipation the output power stage of the module can be disabled using the enable (S3) input.

DISTORTION and NOISE

The noise characteristics of the ECM-300H amplifier module are different from a linear amplifier in that the dominant source of 'noise' is the amplifier switching frequency. This frequency at 450KHz is present even when no audio signal is input to the amplifier. The switching signal is a square wave and will have harmonics of the fundamental frequency e.g. 1.350MHz, 2.25MHz, 3.15MHz etc. The output filter if used, must attenuate this signal and let the audio signal through without attenuation or distortion. A specially designed filter configuration is available that is able to effectively attenuate the switching signal and leave the audio signal unaffected.

Using this filter technology it is possible to attenuate the fundamental of the switching frequency by about 40dB. This filter produces a flat audio passband irrespective of variations in the loudspeaker load, with 5% power loss in the audio passband. Greater attenuation of the switching frequency can be achieved if more attenuation in the audio band is permitted. Profusion is able to supply filters designed to a custom requirement.

To minimise external interference signals the audio connection to the amplifier should be via a low noise screened cable. The amplifier module should not be positioned directly adjacent to mains or similar high level voltages. The power supply used to supply the rail voltage should be regulated with a minimum ripple level of 1% or less.

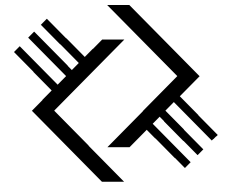

THERMAL EFFICIENCY

The ECM-600H amplifier module comes housed in an aluminium package. Internal to the package, the power components are thermally bonded to the housing. The housing is also electrically bonded to the supply ground. The thermal resistance of the amplifier package in free air is $4^{\circ}\text{C}/\text{W}$ (θ_a). The contact thermal resistance of the amplifier can be assumed to be $0.5^{\circ}\text{C}/\text{W}$ (θ_c).

To decide whether additional heatsinking is required the power level and duty cycle of the music must be estimated. The power level should be determined from the maximum power the unit is asked to produce and is determined by the rail voltage (see above chart of rail voltage versus power into a 4Ω load). Assuming an *inherent efficiency* of 95% means that 5% of the rated power will be dissipated inside the amplifier module. For example, a maximum *theoretical output power* of 300W, 15W will be dissipated inside the amplifier unit. This assumes a continuous sine wave input at full *modulation factor*, somewhat unrealistic for audio signals with their associated *latency*. The actual power levels with audio signals would typically be 25% of the calculated value. If this figure is used then the power dissipation inside the module would be 3.5W.

Once the typical power dissipated inside the module is known the temperature rise using the module at this power can be calculated. The temperature rise is given by:

$$\text{Temperature rise} = \theta_a * \text{power dissipation} \quad (^{\circ}\text{C})$$

With the example above, the temperature rise would be 22.5°C above ambient temperature. The operational temperature of the module should not exceed 70°C . If the calculated temperature rise and the maximum ambient temperature for operation will exceed this figure, then additional heatsinking will be required. If heatsinking is required then the module can be mounted onto an additional heatsink. When mounting to a heatsink, it is recommended that a high thermal conductivity electrical insulating mat is used. If the thermal resistance of the new heatsink is θ_h , then:

$$\text{Temperature rise} = (\theta_c + \theta_h) * \text{power dissipation} \quad (^{\circ}\text{C})$$

If a heatsink with a thermal resistance of $1.5^{\circ}\text{C}/\text{W}$ is selected, then in the above example the temperature rise above ambient would be 15°C .

INPUT CHARACTERISTICS

The input impedance of the standard amplifier module is $7.3\text{K}\Omega$. This value was chosen to provide the best balance between ensuring sufficient impedance to the audio source and minimising the affects of external interference. The amplifier input is differential to ensure common mode noise rejection. The bandwidth of the input amplifier is 80KHz (3dB). This wide bandwidth is designed to afford maximum flexibility to the user. For purely audio applications, an input filter can be incorporated prior to the amplifier module. This additional circuitry can be incorporated as an option inside the amplifier package or alternatively can be configured external to the amplifier. For further discussions of these options, please contact Profusion.

MECHANICAL DETAILS

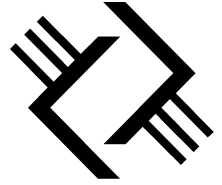

Connections

The amplifier module has been designed such that connections can be made with an edge connector. The edge connector should have the following specification:

Number of ways	32
Pitch	2.54mm (0.1")
Card aperture	82.1mm
Card insertion depth (max)	8.5mm
Working voltage	500VDC
Current per contact	5A
Contact resistance	10m Ω
Breakdown voltage	1KV
Insulation resistance	5 x 10 ⁹ Ω min.
Temperature range	-40°C to +100°C
Insertion / Extraction force	150g max.

The connector connections are (from left to right with connections uppermost) :

Way	Identifier	Function	Remarks
1	S2	Signal ground	Connect to input cableform screen
2			No connection leave free
3	S1	Audio signal	$\pm 1V_{p-p}$ @ 90% modulation factor (this is a differential input)
4			No connection leave free
5	S2	Signal ground	Connect to input cableform screen
6			No connection leave free
7	S3	Enable	Leave unconnected to enable, connect to +5VDC to disable
8			No connection leave free
9	V _{L+}	Positive supply	+10.0 +0.2/-0.1VDC @ 100mA
10			No connection leave free
11	V _{L-}	Negative supply	-10.0 +0.1/-0.2VDC @ 50mA
12			No connection leave free
13-15	GND	Power ground	Connect across all three contacts
16			No connection leave free
17-19	OUT1	Power output	To filter or loudspeaker
20-24			No connection leave free
25-27	OUT2	Power output	To filter or loudspeaker
28			No connection leave free
29-31	V _{RS}	Rail voltage	+10V to 80VDC, connect across all three contacts
32			No connection leave free

In addition to the above, it is recommended that a 100 μ F, 100VDC electrolytic and a low ESR 0.22 μ F capacitor are connected across the ground and rail voltage terminations as close as possible to the terminations or connector.

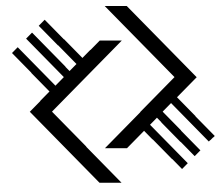

Package dimensions

(All dimensions in mm)

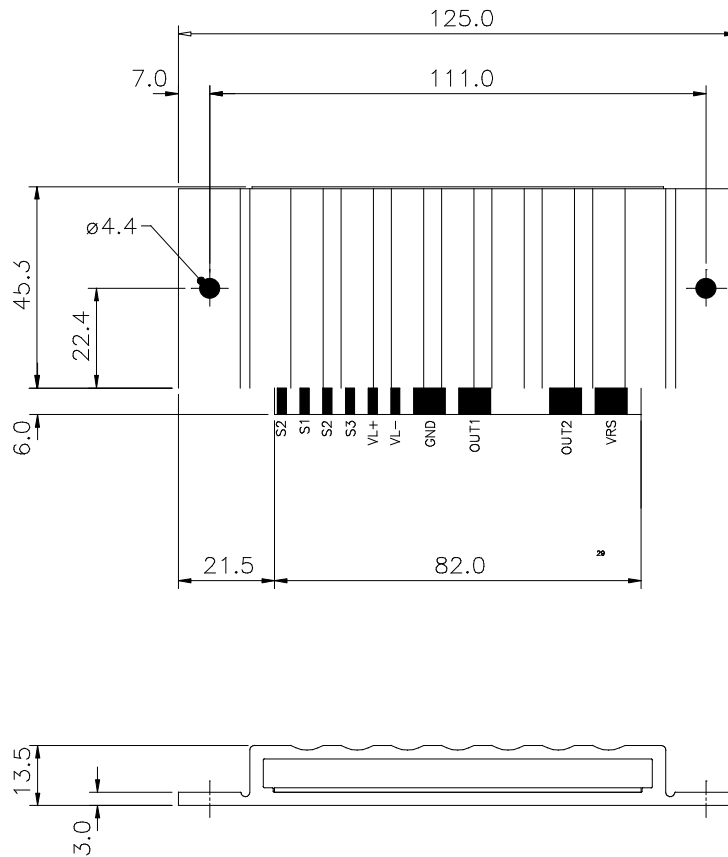

OPTIONS

Various options to the basic amplifier module are available. These options are described below. If a required option is not found please contact Profusion. Custom requirements are subject to a minimum order quantity.

Alternative load configurations

The ECM-300H module is designed to drive into a 4Ω load. Higher value loads can be used with the amplifier, but with proportionally less power at the same rail voltages. To increase the power coupled to the load the rail voltages will have to be increased. If higher power levels than those shown on the graph opposite are required then Profusion can produce a specific variant to drive the alternative load. Contact Profusion for further details.

Rail Voltage versus maximum theoretical power into load

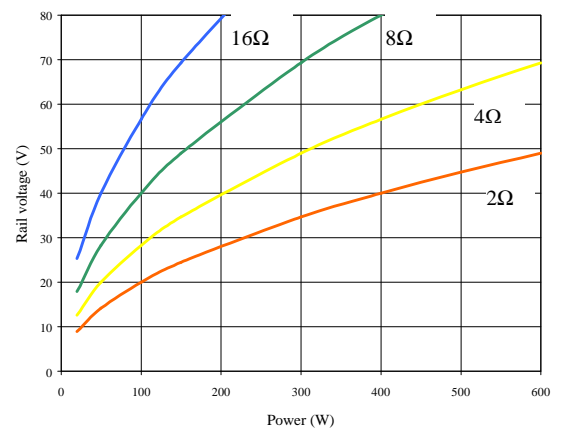

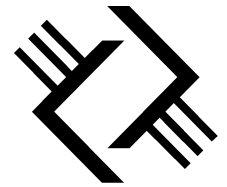

Current monitor

The standard amplifier module does not include short circuit protection. The current monitor enables precise measurement of the amplifier output current and responds in just over $2\mu\text{s}$ to a short circuit condition. The current monitor is a coarse measure due to the nature of loudspeaker loads. The load will fluctuate due to its reactive nature and any current monitor has to allow peak current five times greater than the rms currents. However, if the amplifier module is to be used in situations where the output could be shorted (i.e. during assembly of sound systems), then this option should be considered. The current monitor circuitry can be mounted inside an enlarged module package.

Input characteristics

The input characteristics of the standard module can be tuned to the requirements of different applications. Input parameters that can be readily reconfigured include:

Gain:	Currently configured for input voltage levels up to $\pm 1\text{Vp-p}$. Other options include 0.5Vrms , 1Vrms , 2Vrms , $\pm 0.5\text{Vp-p}$, $\pm 2\text{Vp-p}$, $\pm 3\text{Vp-p}$.
Input impedance:	Currently set at $7.3\text{K}\Omega$, consult Profusion for options suitable to the application.
Filter on input:	Currently set at 100KHz (-3dB point). Other options include multiple pole lowpass filters with roll-offs up to 100KHz .
Anti-clip on input:	For applications where the audio source is not well controlled, the anti-clip circuitry can either disable the amplifier when the signal level reaches a pre-determined threshold or limit internally the modulation factor such that the amplifier will appear to clip like a linear amplifier.

Output filter

The characteristics of the output filter can be adjusted for a particular application. Parameters that can be varied include passband attenuation, stopband attenuation, passband ripple, and switching frequency attenuation. Some of the aforementioned parameters are coupled and cannot be considered independently. For applications where a filter is required please discuss the requirements with Profusion.

Switch-mode, universal input, PFC, PSU module

This product is still under development, release is expected in the coming months. The power supply will be universal input 90 to 264Vac, 50/60Hz, power factor corrected pre-regulator, providing both rail and control voltages for the amplifier modules.

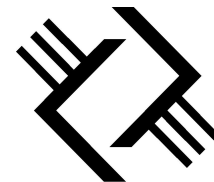

GLOSSARY

Active speaker	Integrated loudspeaker and amplifier.
Audio passband	Audio spectrum from 20Hz to 20KHz.
Anti-clip	Circuit to correct for excessive input signals.
Class D	Amplifier using pulse width modulated output stage.
Decibel	Measure of relative power $\text{dB} = 10\log P1/P2$
EMC	Electro magnetic compatibility
ESR	Equivalent series resistance
Filter attenuation	Performance of a filter at a specific frequency or band of frequencies.
Harmonic	Higher multiple of a frequency
(K)Hz	(Kilo) Hertz, frequency measure
Inherent efficiency	Measure of the efficiency of the amplifier module alone.
Input impedance	Impedance looking into the amplifier.
Latency	Description of the dynamic range of music
Modulation Factor	Ratio of input signal amplitude to maximum permissible signal amplitude.
Noise floor	Residual noise level of the amplifier expressed in dB.
Output impedance	Source impedance seen looking into the amplifier output.
PCB	Printed circuit board
PFC	Power factor corrected
p-p	Peak to peak measurement
PSU	Power supply unit
PWM	Pulse width modulation
Quiescent current	Current consumed by amplifier with no audio signal input.
Rms	Root mean square = $V_{p-p}/(2\sqrt{2})$
Slave module	Additional power output stage driven from an optional master unit.
SNR	Signal to noise ratio
Switching frequency	Sample frequency of PWM.
THD	Total harmonic distortion - measure of the accuracy with which an amplifier replicates an input sine wave.
Theoretical output power	Maximum output power of amplifier module, alone assuming 100% efficiency.
Thermal resistance	Measure of heatsink efficiency
Total coupled power	Actual power coupled from amplifier to load (loudspeaker)
UPS	Uninterruptable power supply