

## LOGIC LEVEL TRIAC

<p><b>TO220-AB</b></p>	<p><b>On-State Current</b> 4 Amp</p> <p><b>Gate Trigger Current</b> 5 mA to 10 mA</p> <p><b>Off-State Voltage</b> 200 V ÷ 600 V</p>
<p>This series of <b>TRIAC</b>s uses a high performance PNP technology.</p> <p>These parts are intended for general purpose AC switching applications with highly inductive loads.</p>	

## Absolute Maximum Ratings, according to IEC publication No. 134

SYMBOL	PARAMETER	CONDITIONS	Min.	Max.	Unit
$I_{T(RMS)}$	RMS On-state Current	All Conduction Angle, $T_C = 110\text{ }^\circ\text{C}$		4	A
$I_{TSM}$	Non-repetitive On-State Current	Full Cycle, 60 Hz		33	A
$I_{TSM}$	Non-repetitive On-State Current	Full Cycle, 50 Hz		30	A
$I^2t$	Fusing Current	$t_p = 10\text{ ms}$ , Half Cycle		4.5	A <sup>2</sup> s
$I_{GM}$	Peak Gate Current	20 $\mu\text{s}$ max. $T_j = 125\text{ }^\circ\text{C}$		4	A
$P_{G(AV)}$	Average Gate Power Dissipation	$T_j = 125\text{ }^\circ\text{C}$		1	W
$di/dt$	Critical rate of rise of on-state current	$I_G = 2 \times I_{GT}$ , $t_r = 100\text{ ns}$ $f = 120\text{ Hz}$ , $T_j = 125\text{ }^\circ\text{C}$	50		A/ $\mu\text{s}$
$T_j$	Operating Temperature		-40	+125	$^\circ\text{C}$
$T_{stg}$	Storage Temperature		-40	+150	$^\circ\text{C}$

SYMBOL	PARAMETER	VOLTAGE			Unit
		B	D	M	
$V_{DRM}$	Repetitive Peak Off State Voltage	200	400	600	V
$V_{RRM}$					

## LOGIC LEVEL TRIAC

## Electrical Characteristics

SYMBOL	PARAMETER	CONDITIONS	Quadrant		SENSITIVITY					Unit
					04	05	07	08	09	
$I_{GT}^{(1)}$	Gate Trigger Current	$V_D = 12 V_{DC}, R_L = 33 \Omega, T_j = 25^\circ C$ $V_D = V_{DRM}$	Q1÷Q3	MAX	5	5	5	10	10	mA
				MAX		5	7		10	mA
$I_{DRM} / I_{RRM}$	Off-State Leakage Current	$V_R = V_{RRM}, T_j = 125^\circ C$ $T_j = 25^\circ C$		MAX	1					mA
				MAX	5					$\mu A$
$V_{to}^{(2)}$	Threshold Voltage	$T_j = 125^\circ C$		MAX	0.9					V
$R_d^{(2)}$	Dynamic Resistance	$T_j = 125^\circ C$		MAX	120					m
$V_{TM}^{(2)}$	On-state Voltage	$I_T = 5.5 \text{ Amp}, t_p = 380 \mu s, T_j = 25^\circ C$		MAX	1.6					V
$V_{GT}$	Gate Trigger Voltage	$V_D = 12 V_{DC}, R_L = 33 \Omega, T_j = 25^\circ C$	Q1÷Q4 <sup>(3)</sup>	MAX	1.3					V
$V_{GD}$	Gate Non Trigger Voltage	$V_D = V_{DRM}, R_L = 3.3K \Omega, T_j = 125^\circ C$	Q1÷Q4 <sup>(3)</sup>	MIN	0.2					V
$I_H^{(2)}$	Holding Current	$I_T = 100 \text{ mA}, \text{ Gate open}, T_j = 25^\circ C$		MAX	15	15	10	15	20	mA
$I_L$	Latching Current	$I_G = 1.2 I_{GT}, T_j = 25^\circ C$	Q1,Q3,Q4 <sup>(4)</sup>	MAX	10	10	10	25	20	mA
			Q2	MAX	20	20	15	30	40	
$dv / dt^{(2)}$	Critical Rate of Voltage Rise	$V_D = 0.67 \times V_{DRM}, \text{ Gate open}$ $T_j = 125^\circ C$		MIN	10	10	20	40	20	V/ $\mu s$
$(di/dt)c^{(2)}$	Critical Rate of Current Rise	$(dv/dt)c = 0.1 \text{ V}/\mu s, T_j = 125^\circ C$ $(dv/dt)c = 10 \text{ V}/\mu s, T_j = 125^\circ C$ without snubber $T_j = 125^\circ C$		MIN	1.5	1.5	1.8	2.7	2.5	A/ms
				MIN	-	-	0.9	2.0	-	
				MIN	-	-	-	-	-	
$R_{th(j-c)}$	Thermal Resistance Junction-Case				2.6					$^\circ C/W$
$R_{th(j-a)}$	Thermal Resistance Junction-Ambient				60					$^\circ C/W$

(1) Minimum  $I_{GT}$  is guaranteed at 5% of  $I_{GT}$  max.

(2) For either polarity of electrode MT2 voltage with reference to electrode MT1.

(3) Q4 for 4 Quadrant Triacs  
Q3 for 3 Quadrant Triacs

(4) Only for 4 Quadrant Triacs

## PART NUMBER INFORMATION

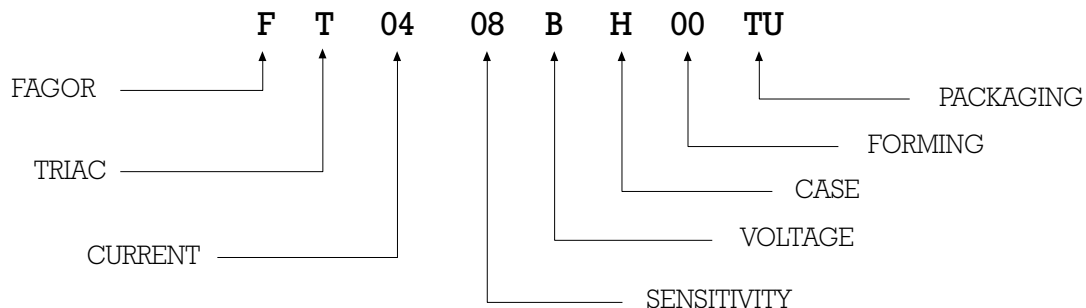

# LOGIC LEVEL TRIAC

Fig. 1: Maximum power dissipation versus RMS on-state current (full cycle).

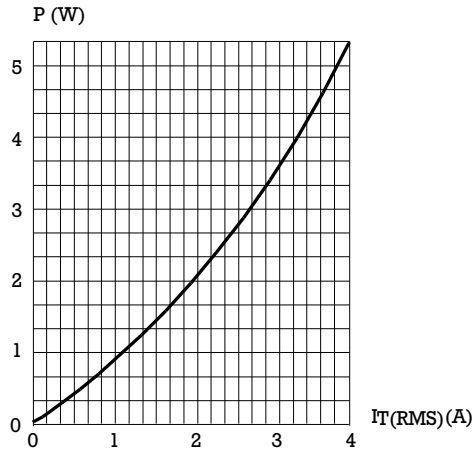

Fig. 3: : Relative variation of thermal impedance versus pulse duration.

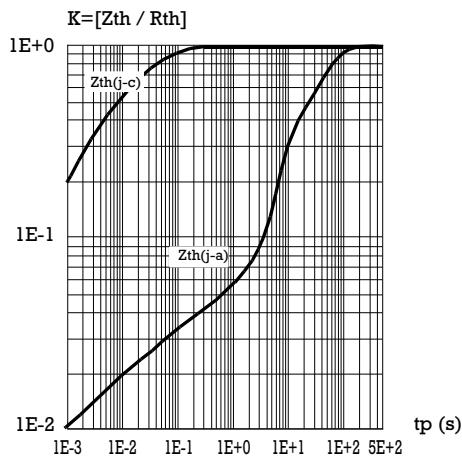

Fig. 5: Surge peak on-state current versus number of cycles

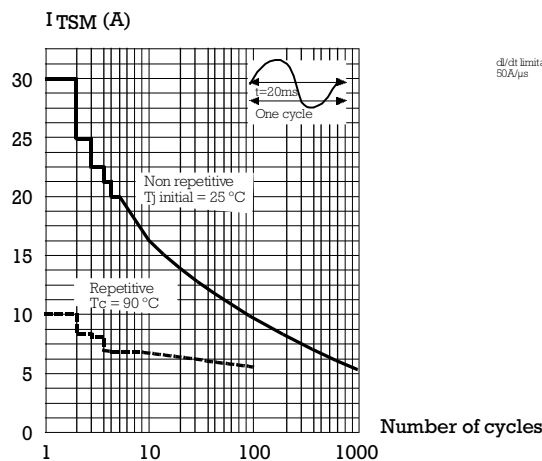

Fig. 2: RMS on-state current versus case temperature (full cycle).

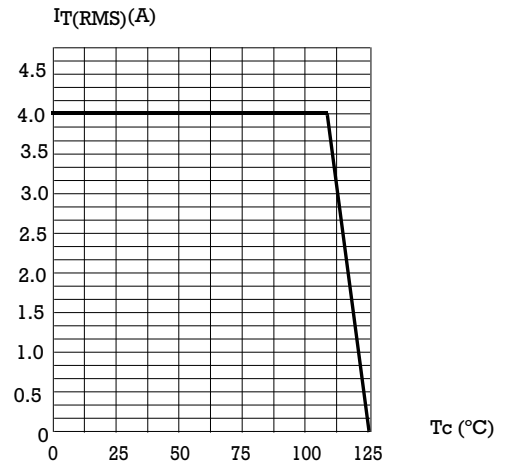

Fig. 4: On-state characteristics (maximum values)

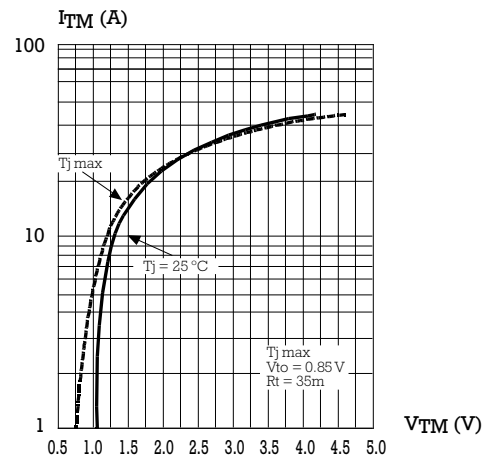
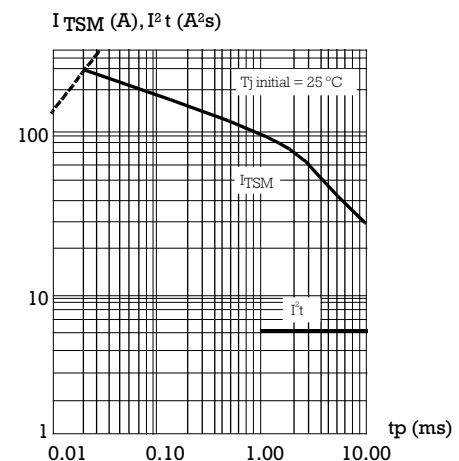

Fig. 6: Non-repetitive surge peak on-state current for a sinusoidal pulse with width  $t_p < 10\text{ms}$ , and corresponding value of  $I^2 t$ .



## LOGIC LEVEL TRIAC

Fig. 7: Relative variation of gate trigger current, holding current and latching current versus junction temperature (typical values)

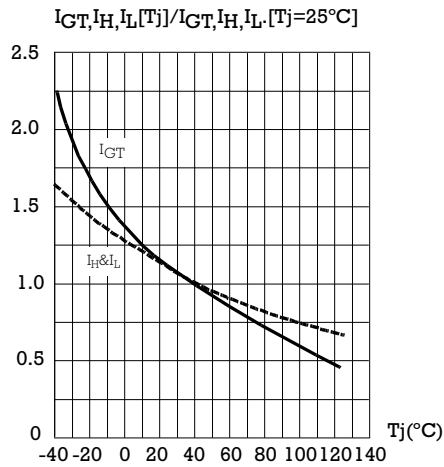
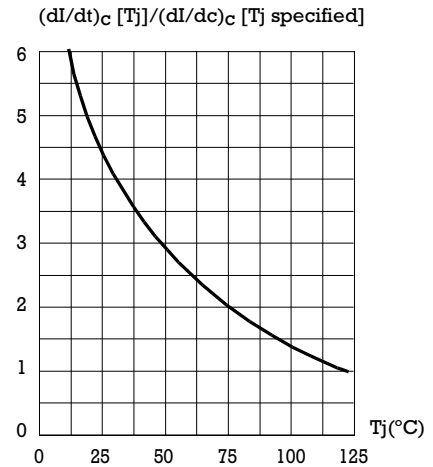

Fig. 8: Relative variation of critical rate of decrease of main current versus junction temperature



### PACKAGE MECHANICAL DATA TO-220AB (Plastic)

