

## 74ABT373

### Octal Transparent Latch with 3-STATE Outputs

#### General Description

The ABT373 consists of eight latches with 3-STATE outputs for bus organized system applications. The flip-flops appear transparent to the data when Latch Enable (LE) is HIGH. When LE is LOW, the data that meets the setup times is latched. Data appears on the bus when the Output Enable ( $\overline{OE}$ ) is LOW. When  $\overline{OE}$  is HIGH the bus output is in the high impedance state.

#### Features

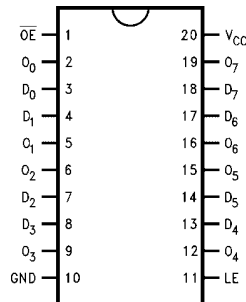
- 3-STATE outputs for bus interfacing
- Output sink capability of 64 mA, source capability of 32 mA
- Guaranteed output skew
- Guaranteed multiple output switching specifications
- Output switching specified for both 50 pF and 250 pF loads
- Guaranteed simultaneous switching, noise level and dynamic threshold performance
- Guaranteed latchup protection
- High impedance glitch free bus loading during entire power up and power down
- Nondestructive hot insertion capability

#### Ordering Code:

Order Number	Package Number	Package Description
74ABT373CSC	M20B	20-Lead Small Outline Integrated Circuit (SOIC), JEDEC MS-013, 0.300" Wide Body
74ABT373CSJ	M20D	20-Lead Small Outline Package (SOP), EIAJ TYPE II, 5.3mm Wide
74ABT373CMSA	MSA20	20-Lead Shrink Small Outline Package (SSOP), EIAJ TYPE II, 5.3mm Wide
74ABT373CMTC	MTC20	20-Lead Thin Shrink Small Outline Package (TSSOP), JEDEC MO-153, 4.4mm Wide
74ABT373CPC	N20A	20-Lead Plastic Dual-In-Line Package (PDIP), JEDEC MS-001, 0.300" Wide

Device also available in Tape and Reel. Specify by appending suffix letter "X" to the ordering code.

#### Connection Diagram



#### Pin Descriptions

Pin Names	Description
$D_0$ – $D_7$	Data Inputs
LE	Latch Enable Input (Active HIGH)
$\overline{OE}$	Output Enable Input (Active LOW)
$O_0$ – $O_7$	3-STATE Latch Outputs

## Functional Description

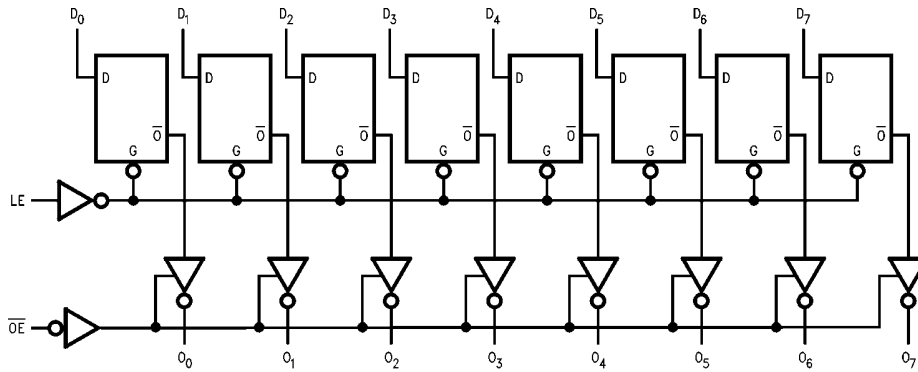
The ABT373 contains eight D-type latches with 3-STATE output buffers. When the Latch Enable (LE) input is HIGH, data on the  $D_n$  inputs enters the latches. In this condition the latches are transparent, i.e., a latch output will change state each time its D input changes. When LE is LOW, the latches store the information that was present on the D inputs at setup time preceding the HIGH-to-LOW transition of LE. The 3-STATE buffers are controlled by the Output Enable ( $\overline{OE}$ ) input. When  $\overline{OE}$  is LOW, the buffers are in the bi-state mode. When  $\overline{OE}$  is HIGH the buffers are in the high impedance mode but this does not interfere with entering new data into the latches.

## Truth Table

Inputs			Output
LE	$\overline{OE}$	$D_n$	$O_n$
H	L	H	H
H	L	L	L
L	L	X	$O_n$ (no change)
X	H	X	Z

H = HIGH Voltage Level  
 L = LOW Voltage Level  
 X = Immaterial  
 Z = HIGH Impedance State

## Logic Diagram



Please note that this diagram is provided only for the understanding of logic operations and should not be used to estimate propagation delays.

Absolute Maximum Ratings <sup>(Note 1)</sup>		Recommended Operating Conditions	
Storage Temperature	-65°C to +150°C	Free Air Ambient Temperature	-40°C to +85°C
Ambient Temperature under Bias	-55°C to +125°C	Supply Voltage	+4.5V to +5.5
Junction Temperature under Bias	-55°C to +150°C	Minimum Input Edge Rate ( $\Delta V/\Delta t$ )	
V <sub>CC</sub> Pin Potential to Ground Pin	-0.5V to +7.0V	Data Input	50 mV/ns
Input Voltage (Note 2)	-0.5V to +7.0V	Enable Input	20 mV/ns
Input Current (Note 2)	-30 mA to +5.0 mA		
Voltage Applied to Any Output in the Disabled or Power-Off State	-0.5V to +5.5V		
in the HIGH State	-0.5V to V <sub>CC</sub>		
Current Applied to Output in LOW State (Max)	twice the rated I <sub>OL</sub> (mA)		
DC Latchup Source Current:			
OE Pin	-150 mA		
(Across Comm Operating Range) Other Pins	-500 mA		
Over Voltage Latchup (I/O)	10V		

**Note 1:** Absolute maximum ratings are values beyond which the device may be damaged or have its useful life impaired. Functional operation under these conditions is not implied.

**Note 2:** Either voltage limit or current limit is sufficient to protect inputs.

### DC Electrical Characteristics

Symbol	Parameter	Min	Typ	Max	Units	V <sub>CC</sub>	Conditions
V <sub>IH</sub>	Input HIGH Voltage	2.0			V		Recognized HIGH Signal
V <sub>IL</sub>	Input LOW Voltage			0.8	V		Recognized LOW Signal
V <sub>CD</sub>	Input Clamp Diode Voltage			-1.2	V	Min	I <sub>IN</sub> = -18 mA
V <sub>OH</sub>	Output HIGH Voltage	2.5			V	Min	I <sub>OH</sub> = -3 mA I <sub>OH</sub> = -32 mA
V <sub>OL</sub>	Output LOW Voltage			0.55	V	Min	I <sub>OL</sub> = 64 mA
I <sub>IH</sub>	Input HIGH Current			1	μA	Max	V <sub>IN</sub> = 2.7V (Note 4) V <sub>IN</sub> = V <sub>CC</sub>
I <sub>BVI</sub>	Input HIGH Current Breakdown Test			7	μA	Max	V <sub>IN</sub> = 7.0V
I <sub>IL</sub>	Input LOW Current			-1	μA	Max	V <sub>IN</sub> = 0.5V (Note 4) V <sub>IN</sub> = 0.0V
V <sub>ID</sub>	Input Leakage Test	4.75			V	0.0	I <sub>ID</sub> = 1.9 μA All Other Pins Grounded
I <sub>OZH</sub>	Output Leakage Current			10	μA	0 - 5.5V	V <sub>OUT</sub> = 2.7V; OE = 2.0V
I <sub>OZL</sub>	Output Leakage Current			-10	μA	0 - 5.5V	V <sub>OUT</sub> = 0.5V; OE = 2.0V
I <sub>OS</sub>	Output Short-Circuit Current	-100		-275	mA	Max	V <sub>OUT</sub> = 0.0V
I <sub>CEx</sub>	Output High Leakage Current			50	μA	Max	V <sub>OUT</sub> = V <sub>CC</sub>
I <sub>ZZ</sub>	Bus Drainage Test			100	μA	0.0	V <sub>OUT</sub> = 5.5V; All Others GND
I <sub>CCH</sub>	Power Supply Current			50	μA	Max	All Outputs HIGH
I <sub>CCL</sub>	Power Supply Current			30	mA	Max	All Outputs LOW
I <sub>CCZ</sub>	Power Supply Current			50	μA	Max	OE = V <sub>CC</sub> All Others at V <sub>CC</sub> or GND
I <sub>CCT</sub>	Additional I <sub>CC</sub> /Input			2.5	mA	Max	V <sub>I</sub> = V <sub>CC</sub> - 2.1V Enable Input V <sub>I</sub> = V <sub>CC</sub> - 2.1V Data Input V <sub>I</sub> = V <sub>CC</sub> - 2.1V All Others at V <sub>CC</sub> or GND
				2.5	mA		
				2.5	mA		
I <sub>CCD</sub>	Dynamic I <sub>CC</sub>	No Load			mA/ MHz	Max	Outputs Open, LE = V <sub>CC</sub> OE = GND, (Note 3) One Bit Toggling, 50% Duty Cycle
	(Note 4)			0.12			

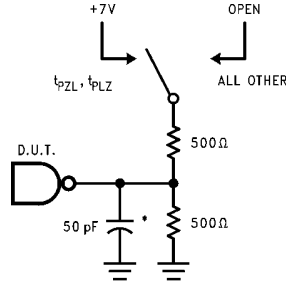
**Note 3:** For 8 bits toggling, I<sub>CCD</sub> < 0.8 mA/MHz.

**Note 4:** Guaranteed, but not tested.

DC Electrical Characteristics									
(SOIC Package)									
Symbol	Parameter	Min	Typ	Max	Units	V <sub>CC</sub>	Conditions C <sub>L</sub> = 50 pF, R <sub>L</sub> = 500Ω		
V <sub>OLP</sub>	Quiet Output Maximum Dynamic V <sub>OL</sub>		0.4	0.8	V	5.0	T <sub>A</sub> = 25°C (Note 5)		
V <sub>OLV</sub>	Quiet Output Minimum Dynamic V <sub>OL</sub>	-1.2	-0.8		V	5.0	T <sub>A</sub> = 25°C (Note 5)		
V <sub>OHV</sub>	Minimum HIGH Level Dynamic Output Voltage	2.5	3.0		V	5.0	T <sub>A</sub> = 25°C (Note 6)		
V <sub>IHD</sub>	Minimum HIGH Level Dynamic Input Voltage	2.0	1.7		V	5.0	T <sub>A</sub> = 25°C (Note 7)		
V <sub>ILD</sub>	Maximum LOW Level Dynamic Input Voltage		0.9	0.6	V	5.0	T <sub>A</sub> = 25°C (Note 7)		
<p><b>Note 5:</b> Max number of outputs defined as (n). n – 1 data inputs are driven 0V to 3V. One output at Low. Guaranteed, but not tested.</p> <p><b>Note 6:</b> Max number of outputs defined as (n). n – 1 data inputs are driven 0V to 3V. One output HIGH. Guaranteed, but not tested.</p> <p><b>Note 7:</b> Max number of data inputs (n) switching. n – 1 inputs switching 0V to 3V. Input-under-test switching: 3V to threshold (V<sub>ILD</sub>), 0V to threshold (V<sub>IHD</sub>). Guaranteed, but not tested.</p>									
AC Electrical Characteristics									
(SOIC and SSOP Packages)									
Symbol	Parameter	T <sub>A</sub> = +25°C V <sub>CC</sub> = +5.0V C <sub>L</sub> = 50 pF			T <sub>A</sub> = -55°C to +125°C V <sub>CC</sub> = 4.5V to 5.5V C <sub>L</sub> = 50 pF		T <sub>A</sub> = -40°C to +85°C V <sub>CC</sub> = 4.5V to 5.5V C <sub>L</sub> = 50 pF		Units
		Min	Typ	Max	Min	Max	Min	Max	
t <sub>PLH</sub>	Propagation Delay	1.9	2.7	4.5	1.0	6.8	1.9	4.5	ns
t <sub>PHL</sub>	D <sub>n</sub> to O <sub>n</sub>	1.9	2.8	4.5	1.0	7.0	1.9	4.5	
t <sub>PLH</sub>	Propagation Delay	2.0	3.1	5.0	1.0	7.7	2.0	5.0	ns
t <sub>PHL</sub>	LE to O <sub>n</sub>	2.0	3.0	5.0	1.5	7.7	2.0	5.0	
t <sub>PZH</sub>	Output Enable Time	1.5	3.1	5.3	1.0	6.7	1.5	5.3	ns
t <sub>PZL</sub>		1.5	3.1	5.3	1.5	7.2	1.5	5.3	
t <sub>PHZ</sub>	Output Disable Time	2.0	3.6	5.4	1.7	8.0	2.0	5.4	ns
t <sub>PLZ</sub>		2.0	3.4	5.4	1.0	7.0	2.0	5.4	
AC Operating Requirements									
(SOIC and SSOP Packages)									
Symbol	Parameter	T <sub>A</sub> = +25°C V <sub>CC</sub> = +5.0V C <sub>L</sub> = 50 pF			T <sub>A</sub> = -55°C to +125°C V <sub>CC</sub> = 4.5V to 5.5V C <sub>L</sub> = 50 pF		T <sub>A</sub> = -40°C to +85°C V <sub>CC</sub> = 4.5V to 5.5V C <sub>L</sub> = 50 pF		Units
		Min	Typ	Max	Min	Max	Min	Max	
t <sub>TOGGLE</sub>	Max Toggle Frequency		100		100				MHz
t <sub>S(H)</sub>	Setup Time, HIGH	1.5			2.5		1.5		ns
t <sub>S(L)</sub>	or LOW D <sub>n</sub> to LE	1.5			2.5		1.5		
t <sub>H(H)</sub>	Hold Time, HIGH	1.0			2.5		1.0		ns
t <sub>H(L)</sub>	or LOW D <sub>n</sub> to LE	1.0			2.5		1.0		
t <sub>W(H)</sub>	Pulse Width, LE HIGH	3.0			3.3		3.0		ns

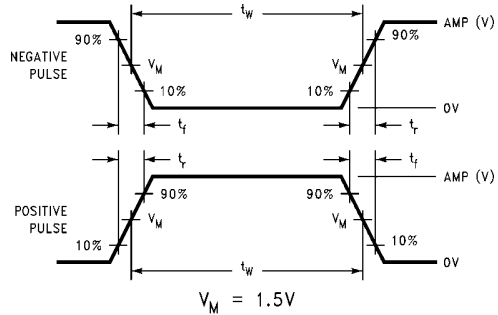
Extended AC Electrical Characteristics								
(SOIC Package)								
Symbol	Parameter	$T_A = -40^\circ\text{C to } +85^\circ\text{C}$ $V_{CC} = 4.5\text{V to } 5.5\text{V}$ $C_L = 50\text{ pF}$ 8 Outputs Switching (Note 8)		$T_A = -40^\circ\text{C to } +85^\circ\text{C}$ $V_{CC} = 4.5\text{V to } 5.5\text{V}$ $C_L = 250\text{ pF}$ (Note 9)		$T_A = -40^\circ\text{C to } +85^\circ\text{C}$ $V_{CC} = 4.5\text{V to } 5.5\text{V}$ $C_L = 250\text{ pF}$ 8 Outputs Switching (Note 10)		Units
		Min	Max	Min	Max	Min	Max	
$t_{PLH}$	Propagation Delay $D_n$ to $O_n$	1.5	5.2	2.0	6.8	2.0	9.0	ns
$t_{PHL}$		1.5	5.2	2.0	6.8	2.0	9.0	
$t_{PLH}$	Propagation Delay	1.5	5.5	2.0	7.5	2.0	9.5	ns
$t_{PHL}$	LE to $O_n$	1.5	5.5	2.0	7.5	2.0	9.5	
$t_{PZH}$	Output Enable Time	1.5	6.2	2.0	8.0	2.0	10.5	ns
$t_{PZL}$		1.5	6.2	2.0	8.0	2.0	10.5	
$t_{PHZ}$	Output Disable Time	1.0	5.5	(Note 11)		(Note 11)		ns
$t_{PZL}$		1.0	5.5					
<p><b>Note 8:</b> This specification is guaranteed but not tested. The limits apply to propagation delays for all paths described switching in phase (i.e., all LOW-to-HIGH, HIGH-to-LOW, etc.).</p> <p><b>Note 9:</b> This specification is guaranteed but not tested. The limits represent propagation delay with 250 pF load capacitors in place of the 50 pF load capacitors in the standard AC load. This specification pertains to single output switching only.</p> <p><b>Note 10:</b> This specification is guaranteed but not tested. The limits represent propagation delays for all paths described switching in phase (i.e., all LOW-to-HIGH, HIGH-to-LOW, etc.) with 250 pF load capacitors in place of the 50 pF load capacitors in the standard AC load.</p> <p><b>Note 11:</b> The 3-STATE delay times are dominated by the RC network (500Ω, 250 pF) on the output and has been excluded from the datasheet.</p>								
Skew								
(SOIC Package)								
Symbol	Parameter	$T_A = -40^\circ\text{C to } +85^\circ\text{C}$ $V_{CC} = 4.5\text{V} - 5.5\text{V}$ $C_L = 50\text{ pF}$ 8 Outputs Switching (Note 12)		$T_A = -40^\circ\text{C to } +85^\circ\text{C}$ $V_{CC} = 4.5\text{V} - 5.5\text{V}$ $C_L = 250\text{ pF}$ 8 Outputs Switching (Note 13)		Units		
		Max		Max				
$t_{OSHL}$ (Note 14)	Pin to Pin Skew, HL Transitions	1.0		1.5		ns		
$t_{OSLH}$ (Note 14)	Pin to Pin Skew, LH Transitions	1.0		1.5		ns		
$t_{PS}$ (Note 16)	Duty Cycle, LH-HL Skew	1.4		3.5		ns		
$t_{OST}$ (Note 14)	Pin to Pin Skew, LH/HL Transitions	1.5		3.9		ns		
$t_{PV}$ (Note 15)	Device to Device Skew, LH/HL Transitions	2.0		4.0		ns		
<p><b>Note 12:</b> This specification is guaranteed but not tested. The limits represent propagation delays with 250 pF load capacitors in place of the 50 pF load capacitors in the standard AC load.</p> <p><b>Note 13:</b> This specification is guaranteed but not tested. The limits apply to propagation delays for all paths described switching in phase (i.e., all LOW-to-HIGH, HIGH-to-LOW, etc.).</p> <p><b>Note 14:</b> Skew is defined as the absolute value of the difference between the actual propagation delays for any two separate outputs of the same device. The specification applies to any outputs switching HIGH-to-LOW (<math>t_{OSHL}</math>), LOW-to-HIGH (<math>t_{OSLH}</math>), or any combination switching LOW-to-HIGH and/or HIGH-to-LOW (<math>t_{OST}</math>). This specification is guaranteed but not tested.</p> <p><b>Note 15:</b> Propagation delay variation is for a given set of conditions (i.e., temperature and <math>V_{CC}</math>) from device to device. This specification is guaranteed but not tested.</p> <p><b>Note 16:</b> This describes the difference between the delay of the LOW-to-HIGH and the HIGH-to-LOW transition on the same pin. It is measured across all the outputs (drivers) on the same chip, the worst (largest delta) number is the guaranteed specification. This specification is guaranteed but not tested.</p>								
Capacitance								
Symbol	Parameter	Typ	Units	Conditions ( $T_A = 25^\circ\text{C}$ )				
$C_{IN}$	Input Capacitance	5	pF	$V_{CC} = 0\text{V}$				
$C_{OUT}$ (Note 17)	Output Capacitance	9	pF	$V_{CC} = 5.0\text{V}$				
<p><b>Note 17:</b> <math>C_{OUT}</math> is measured at frequency <math>f = 1\text{ MHz}</math>, per MIL-STD-883, Method 3012.</p>								

**AC Loading**



\*Includes jig and probe capacitance

**FIGURE 1. Standard AC Test Load**

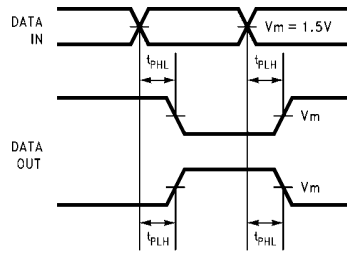


**FIGURE 2. Test Input Signal Levels**

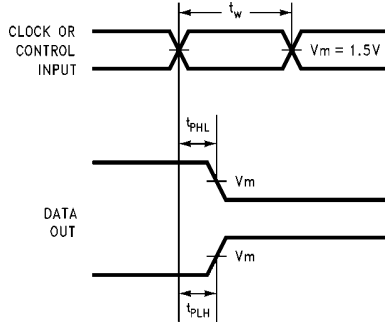
Amplitude	Rep. Rate	$t_w$	$t_r$	$t_f$
3.0V	1 MHz	500 ns	2.5 ns	2.5 ns

**FIGURE 3. Test Input Signal Requirements**

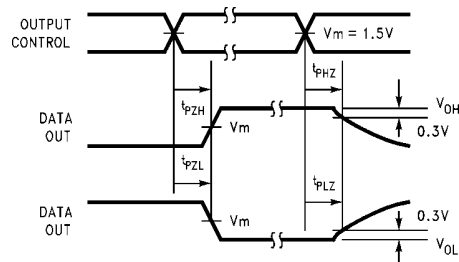
**AC Waveforms**



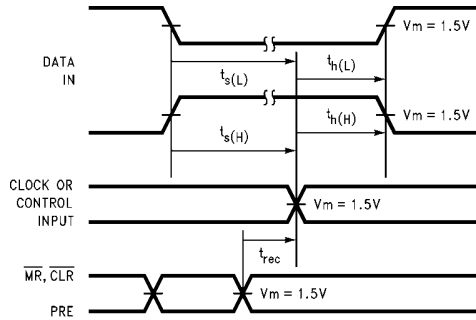
**FIGURE 4. Propagation Delay Waveforms for Inverting and Non-Inverting Functions**



**FIGURE 5. Propagation Delay, Pulse Width Waveforms**

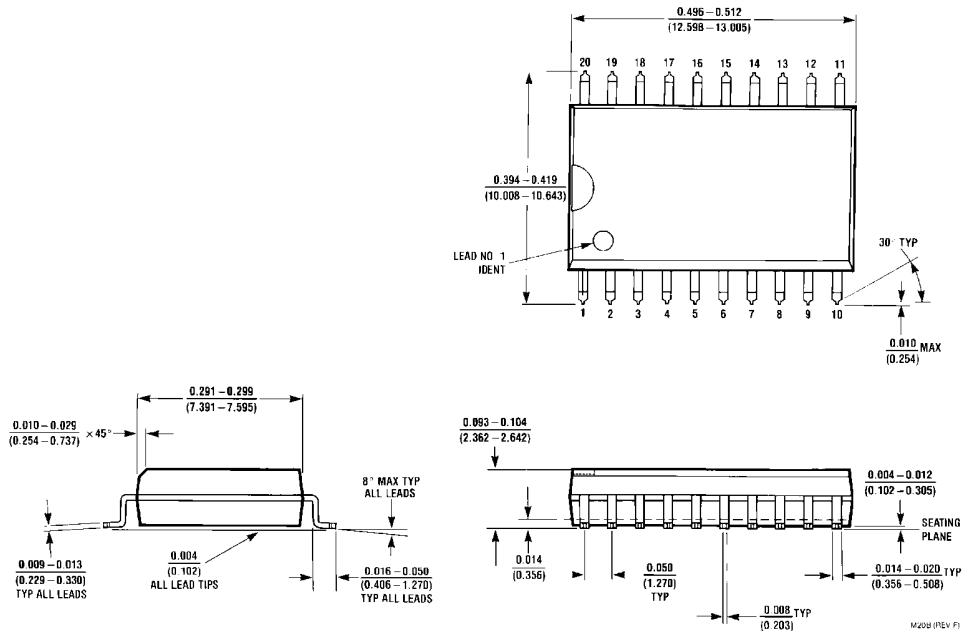


**FIGURE 6. 3-STATE Output HIGH and LOW Enable and Disable Times**



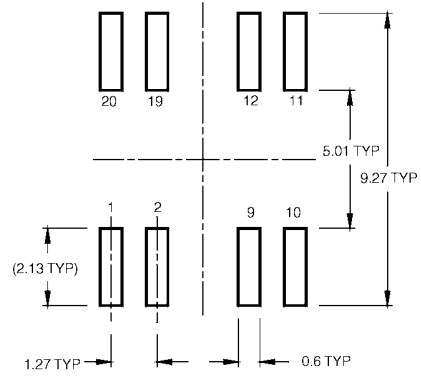
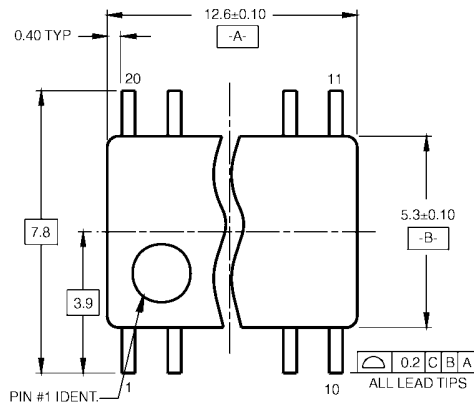
**FIGURE 7. Setup Time, Hold Time and Recovery Time Waveforms**

**Physical Dimensions** inches (millimeters) unless otherwise noted

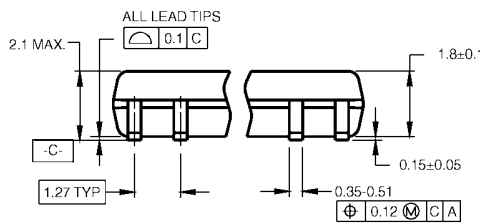


**20-Lead Small Outline Integrated Circuit (SOIC), JEDEC MS-013, 0.300" Wide Body  
Package Number M20B**

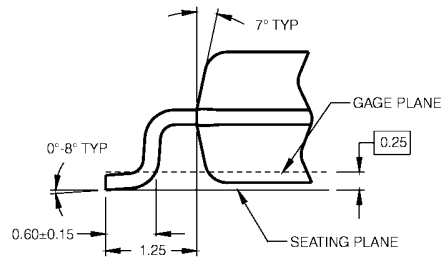
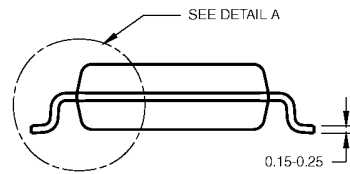
**Physical Dimensions** inches (millimeters) unless otherwise noted (Continued)



LAND PATTERN RECOMMENDATION



DIMENSIONS ARE IN MILLIMETERS



DETAIL A

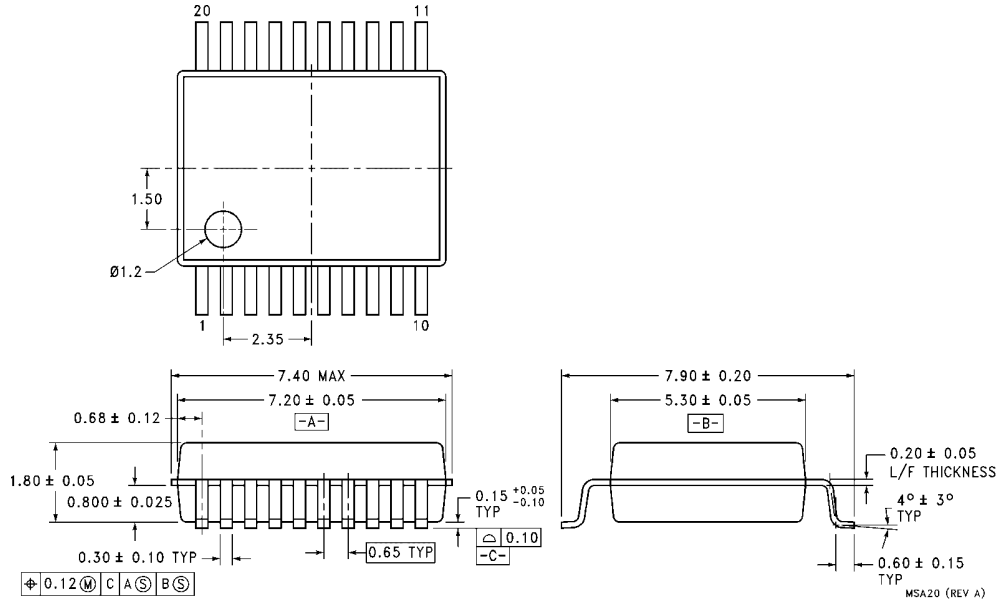
- NOTES:  
 A. CONFORMS TO EIAJ EDR-7320 REGISTRATION, ESTABLISHED IN DECEMBER, 1998.  
 B. DIMENSIONS ARE IN MILLIMETERS.  
 C. DIMENSIONS ARE EXCLUSIVE OF BURRS, MOLD FLASH, AND TIE BAR EXTRUSIONS.

M20DRRevB1

**20-Lead Small Outline Package (SOP), EIAJ TYPE II, 5.3mm Wide Package Number M20D**

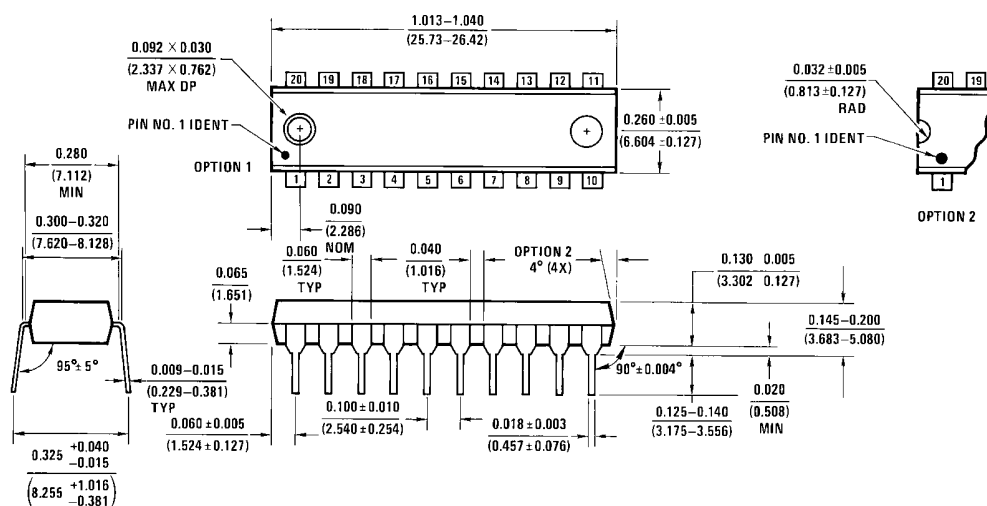


**Physical Dimensions** inches (millimeters) unless otherwise noted (Continued)





**Physical Dimensions** inches (millimeters) unless otherwise noted (Continued)



**20-Lead Plastic Dual-In-Line Package (PDIP), JEDEC MS-001, 0.300" Wide  
Package Number N20A**

N20A (REV G)

Fairchild does not assume any responsibility for use of any circuitry described, no circuit patent licenses are implied and Fairchild reserves the right at any time without notice to change said circuitry and specifications.

**LIFE SUPPORT POLICY**

FAIRCHILD'S PRODUCTS ARE NOT AUTHORIZED FOR USE AS CRITICAL COMPONENTS IN LIFE SUPPORT DEVICES OR SYSTEMS WITHOUT THE EXPRESS WRITTEN APPROVAL OF THE PRESIDENT OF FAIRCHILD SEMICONDUCTOR CORPORATION. As used herein:

1. Life support devices or systems are devices or systems which, (a) are intended for surgical implant into the body, or (b) support or sustain life, and (c) whose failure to perform when properly used in accordance with instructions for use provided in the labeling, can be reasonably expected to result in a significant injury to the user.
2. A critical component in any component of a life support device or system whose failure to perform can be reasonably expected to cause the failure of the life support device or system, or to affect its safety or effectiveness.

[www.fairchildsemi.com](http://www.fairchildsemi.com)