

74AC253 • 74ACT253 Dual 4-Input Multiplexer with 3-STATE Outputs

General Description

The AC/ACT253 is a dual 4-input multiplexer with 3-STATE outputs. It can select two bits of data from four sources using common select inputs. The outputs may be individually switched to a high impedance state with a HIGH on the respective Output Enable (\overline{OE}) inputs, allowing the outputs to interface directly with bus oriented systems.

Features

- I_{CC} and I_{OZ} reduced by 50%
- Multifunction capability
- Noninverting 3-STATE outputs
- Outputs source/sink 24 mA
- ACT253 has TTL-compatible inputs

Ordering Code:

| Order Number | Package Number | Package Description |
|--------------|----------------|---|
| 74AC253SC | M16A | 16-Lead Small Outline Integrated Circuit (SOIC), JEDEC MS-012, 0.150" Narrow Body |
| 74AC253SJ | M16D | 16-Lead Small Outline Package (SOP), EIAJ TYPE II, 5.3mm Wide |
| 74AC253PC | N16E | 16-Lead Plastic Dual-In-Line Package (PDIP), JEDEC MS-001, 0.300" Wide |
| 74ACT253SC | M16A | 16-Lead Small Outline Integrated Circuit (SOIC), JEDEC MS-012, 0.150" Narrow Body |
| 74ACT253SJ | M16D | 16-Lead Small Outline Package (SOP), EIAJ TYPE II, 5.3mm Wide |
| 74ACT253PC | N16E | 16-Lead Plastic Dual-In-Line Package (PDIP), JEDEC MS-001, 0.300" Wide |

Device also available Tape and Reel. Specify by appending suffix letter "X" to the ordering code.

Logic Diagrams

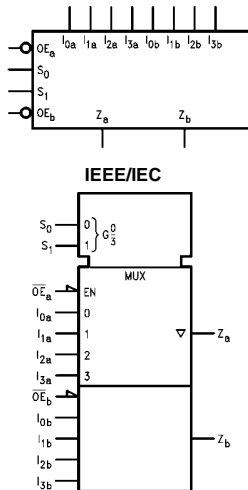

Connection Diagram

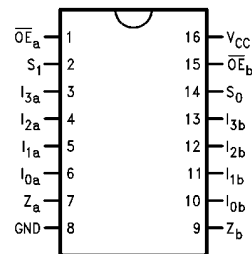

Pin Descriptions

| Pin Names | Description |
|---------------------|----------------------------|
| I_{0a} - I_{3a} | Side A Data Inputs |
| I_{0b} - I_{3b} | Side B Data Inputs |
| S_0 , S_1 | Common Select Inputs |
| \overline{OE}_a | Side A Output Enable Input |
| \overline{OE}_b | Side B Output Enable Input |
| Z_a , Z_b | 3-STATE Outputs |

FACT™ is a trademark of Fairchild Semiconductor Corporation.

Functional Description

The AC/ACT253 contains two identical 4-input multiplexers with 3-STATE outputs. They select two bits from four sources selected by common Select inputs (S_0, S_1). The 4-input multiplexers have individual Output Enable ($\overline{OE}_a, \overline{OE}_b$) inputs which, when HIGH, force the outputs to a high impedance (High Z) state. This device is the logic implementation of a 2-pole, 4-position switch, where the position of the switch is determined by the logic levels supplied to the two select inputs. The logic equations for the outputs are shown:

$$Z_a = \overline{OE}_a \cdot (I_{0a} \cdot \overline{S_1} \cdot \overline{S_0} + I_{1a} \cdot \overline{S_1} \cdot S_0 + I_{2a} \cdot S_1 \cdot \overline{S_0} + I_{3a} \cdot S_1 \cdot S_0)$$

$$Z_b = \overline{OE}_b \cdot (I_{0b} \cdot \overline{S_1} \cdot \overline{S_0} + I_{1b} \cdot \overline{S_1} \cdot S_0 + I_{2b} \cdot S_1 \cdot \overline{S_0} + I_{3b} \cdot S_1 \cdot S_0)$$

If the outputs of 3-STATE devices are tied together, all but one device must be in the high impedance state to avoid high currents that would exceed the maximum ratings. Designers should ensure that Output Enable signals to 3-STATE devices whose outputs are tied together are designed so that there is no overlap.

Truth Table

| Select Inputs | | Data Inputs | | | | Output Enable | Outputs |
|---------------|-------|-------------|-------|-------|-------|-----------------|---------|
| S_0 | S_1 | I_0 | I_1 | I_2 | I_3 | \overline{OE} | Z |
| X | X | X | X | X | X | H | Z |
| L | L | L | X | X | X | L | L |
| L | L | H | X | X | X | L | H |
| H | L | X | L | X | X | L | L |
| H | L | X | H | X | X | L | H |
| L | H | X | X | L | X | L | L |
| L | H | X | X | H | X | L | H |
| H | H | X | X | X | L | L | L |
| H | H | X | X | X | H | L | H |

Address Inputs S_0 and S_1 are common to both sections.

H = HIGH Voltage Level
 L = LOW Voltage Level
 X = Immaterial
 Z = High Impedance

Logic Diagram

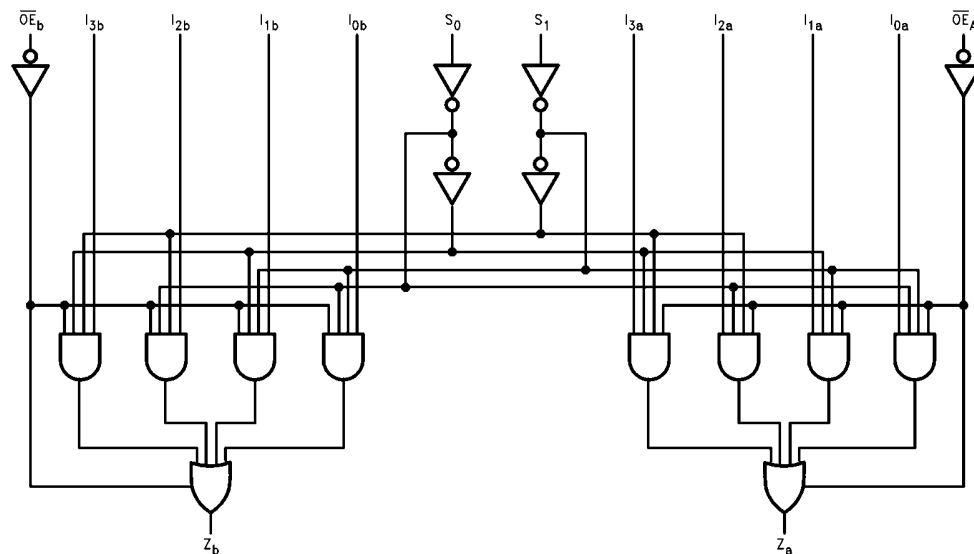

Please note that this diagram is provided only for the understanding of logic operations and should not be used to estimate propagation delays.

Absolute Maximum Ratings(Note 1)

| | |
|--|--------------------------|
| Supply Voltage (V_{CC}) | -0.5V to +7.0V |
| DC Input Diode Current (I_{IK}) | |
| $V_I = -0.5V$ | -20 mA |
| $V_I = V_{CC} + 0.5V$ | +20 mA |
| DC Input Voltage (V_I) | -0.5V to $V_{CC} + 0.5V$ |
| DC Output Diode Current (I_{OK}) | |
| $V_O = -0.5V$ | -20 mA |
| $V_O = V_{CC} + 0.5V$ | +20 mA |
| DC Output Voltage (V_O) | -0.5V to $V_{CC} + 0.5V$ |
| DC Output Source | |
| or Sink Current (I_O) | ± 50 mA |
| DC V_{CC} or Ground Current | |
| per Output Pin (I_{CC} or I_{GND}) | ± 50 mA |
| Storage Temperature (T_{STG}) | -65°C to +150°C |
| Junction Temperature (T_J) | |
| PDIP | 140°C |

Recommended Operating Conditions

| | |
|---|----------------|
| Supply Voltage (V_{CC}) | |
| AC | 2.0V to 6.0V |
| ACT | 4.5V to 5.5V |
| Input Voltage (V_I) | 0V to V_{CC} |
| Output Voltage (V_O) | 0V to V_{CC} |
| Operating Temperature (T_A) | -40°C to +85°C |
| Minimum Input Edge Rate ($\Delta V/\Delta t$) | |
| AC Devices | |
| V_{IN} from 30% to 70% of V_{CC} | |
| V_{CC} @ 3.3V, 4.5V, 5.5V | 125 mV/ns |
| Minimum Input Edge Rate ($\Delta V/\Delta t$) | |
| ACT Devices | |
| V_{IN} from 0.8V to 2.0V | |
| V_{CC} @ 4.5V, 5.5V | 125 mV/ns |

Note 1: Absolute maximum ratings are those values beyond which damage to the device may occur. The databook specifications should be met, without exception, to ensure that the system design is reliable over its power supply, temperature, and output/input loading variables. Fairchild does not recommend operation of FACT™ circuits outside databook specifications.

DC Electrical Characteristics for AC

| Symbol | Parameter | V_{CC} (V) | $T_A = +25^\circ\text{C}$ | | $T_A = -40^\circ\text{C to } +85^\circ\text{C}$ | | Units | Conditions |
|-------------------|--------------------------------------|-----------------|---------------------------|-------------------|---|---------|---|---|
| | | | Typ | Guaranteed Limits | | | | |
| V_{IH} | Minimum HIGH Level Input Voltage | 3.0 | 1.5 | 2.1 | 2.1 | V | $V_{OUT} = 0.1V$ or $V_{CC} - 0.1V$ | |
| | | 4.5 | 2.25 | 3.15 | 3.15 | | | |
| | | 5.5 | 2.75 | 3.85 | 3.85 | | | |
| V_{IL} | Maximum LOW Level Input Voltage | 3.0 | 1.5 | 0.9 | 0.9 | V | $V_{OUT} = 0.1V$ or $V_{CC} - 0.1V$ | |
| | | 4.5 | 2.25 | 1.35 | 1.35 | | | |
| | | 5.5 | 2.75 | 1.65 | 1.65 | | | |
| V_{OH} | Minimum HIGH Level Output Voltage | 3.0 | 2.99 | 2.9 | 2.9 | V | $I_{OUT} = -50 \mu A$ | |
| | | 4.5 | 4.49 | 4.4 | 4.4 | | | |
| | | 5.5 | 5.49 | 5.4 | 5.4 | | | |
| | | | 3.0 | | 2.56 | 2.46 | V | $V_{IN} = V_{IL}$ or V_{IH} $I_{OH} = -12$ mA $I_{OH} = -24$ mA $I_{OH} = -24$ mA (Note 2) |
| | | | 4.5 | | 3.86 | 3.76 | | |
| | | | 5.5 | | 4.86 | 4.76 | | |
| V_{OL} | Maximum LOW Level Output Voltage | 3.0 | 0.002 | 0.1 | 0.1 | V | $I_{OUT} = 50 \mu A$ | |
| | | 4.5 | 0.001 | 0.1 | 0.1 | | | |
| | | 5.5 | 0.001 | 0.1 | 0.1 | | | |
| | | | 3.0 | | 0.36 | 0.44 | V | $V_{IN} = V_{IL}$ or V_{IH} $I_{OL} = 12$ mA $I_{OL} = 24$ mA $I_{OL} = 24$ mA (Note 2) |
| | | | 4.5 | | 0.36 | 0.44 | | |
| | | | 5.5 | | 0.36 | 0.44 | | |
| I_{IN} (Note 4) | Maximum Input Leakage Current | 5.5 | | ± 0.1 | ± 1.0 | μA | $V_I = V_{CC}, GND$ | |
| I_{OZ} | Maximum 3-STATE Current | 5.5 | | ± 0.25 | ± 2.5 | μA | $V_I (OE) = V_{IL}, V_{IH}$ $V_I = V_{CC}, GND$ $V_O = V_{CC}, GND$ | |
| I_{OLD} | Minimum Dynamic | 5.5 | | | 75 | mA | $V_{OLD} = 1.65V$ Max | |
| I_{OHD} | Output Current (Note 3) | 5.5 | | | -75 | mA | $V_{OHD} = 3.85V$ Min | |
| I_{CC} (Note 4) | Maximum Quiescent Supply Current | 5.5 | | 4.0 | 40.0 | μA | $V_{IN} = V_{CC}$ or GND | |

Note 2: All outputs loaded; thresholds on input associated with output under test.

Note 3: Maximum test duration 2.0 ms, one output loaded at a time.

Note 4: I_{IN} and I_{CC} @ 3.0V are guaranteed to be less than or equal to the respective limit @ 5.5V V_{CC} .

| DC Electrical Characteristics for ACT | | | | | | | | |
|---|---|------------------------------------|--|-------------------|---------------------------------|---|---|------------|
| Symbol | Parameter | V _{CC} (V) | T _A = +25°C | | T _A = -40°C to +85°C | | Units | Conditions |
| | | | Typ | Guaranteed Limits | | | | |
| V _{IH} | Minimum HIGH Level Input Voltage | 4.5 | 1.5 | 2.0 | 2.0 | V | V _{OUT} = 0.1V or V _{CC} - 0.1V | |
| | | 5.5 | 1.5 | 2.0 | 2.0 | | | |
| V _{IL} | Maximum LOW Level Input Voltage | 4.5 | 1.5 | 0.8 | 0.8 | V | V _{OUT} = 0.1V or V _{CC} - 0.1V | |
| | | 5.5 | 1.5 | 0.8 | 0.8 | | | |
| V _{OH} | Minimum HIGH Level Output Voltage | 4.5 | 4.49 | 4.4 | 4.4 | V | I _{OUT} = -50 μA | |
| | | 5.5 | 5.49 | 5.4 | 5.4 | | | |
| | | 4.5 | | 3.86 | 3.76 | V | V _{IN} = V _{IL} or V _{IH} I _{OH} = -24 mA I _{OH} = -24 mA (Note 5) | |
| | | 5.5 | | 4.86 | 4.76 | | | |
| V _{OL} | Maximum LOW Level Output Voltage | 4.5 | 0.001 | 0.1 | 0.1 | V | I _{OUT} = 50 μA | |
| | | 5.5 | 0.001 | 0.1 | 0.1 | | | |
| | | 4.5 | | 0.36 | 0.44 | V | V _{IN} = V _{IL} or V _{IH} I _{OL} = 24 mA I _{OL} = 24 mA (Note 5) | |
| | | 5.5 | | 0.36 | 0.44 | | | |
| I _{IN} | Maximum Input Leakage Current | 5.5 | | ±0.1 | ±1.0 | μA | V _I = V _{CC} , GND | |
| I _{OZ} | Maximum 3-STATE Current | 5.5 | | ±0.25 | ±2.5 | μA | V _I = V _{IL} , V _{IH} V _O = V _{CC} , GND | |
| I _{CCT} | Maximum I _{CC} /Input | 5.5 | 0.6 | | 1.5 | mA | V _I = V _{CC} - 2.1V | |
| I _{OLD} | Minimum Dynamic | 5.5 | | | 75 | mA | V _{OLD} = 1.65V Max | |
| I _{OHD} | Output Current (Note 6) | 5.5 | | | -75 | mA | V _{OHD} = 3.85V Min | |
| I _{CC} | Maximum Quiescent Supply Current | 5.5 | | 4.0 | 40.0 | μA | V _{IN} = V _{CC} or GND | |
| <p>Note 5: All outputs loaded; thresholds on input associated with output under test.</p> <p>Note 6: Maximum test duration 2.0 ms, one output loaded at a time.</p> | | | | | | | | |
| AC Electrical Characteristics for AC | | | | | | | | |
| Symbol | Parameter | V _{CC} (V) (Note 7) | T _A = +25°C C _L = 50 pF | | | T _A = -40°C to +85°C C _L = 50 pF | | Units |
| | | | Min | Typ | Max | Min | Max | |
| t _{PLH} | Propagation Delay S _n to Z _n | 3.3 | 2.0 | 8.5 | 15.5 | 2.0 | 17.5 | ns |
| | | 5.0 | 2.0 | 6.5 | 11.0 | 1.5 | 12.5 | |
| t _{PHL} | Propagation Delay S _n to Z _n | 3.3 | 2.5 | 9.5 | 16.0 | 2.0 | 18.0 | ns |
| | | 5.0 | 2.0 | 7.0 | 11.5 | 1.5 | 13.0 | |
| t _{PLH} | Propagation Delay I _n to Z _n | 3.3 | 1.5 | 7.0 | 14.5 | 1.5 | 17.0 | ns |
| | | 5.0 | 1.5 | 5.5 | 10.0 | 1.5 | 11.5 | |
| t _{PHL} | Propagation Delay I _n to Z _n | 3.3 | 2.0 | 7.5 | 13.0 | 1.5 | 15.0 | ns |
| | | 5.0 | 1.5 | 5.5 | 9.5 | 1.5 | 11.0 | |
| t _{PZH} | Output Enable Time | 3.3 | 1.5 | 4.5 | 8.0 | 1.0 | 8.5 | ns |
| | | 5.0 | 1.5 | 3.5 | 6.0 | 1.0 | 6.5 | |
| t _{PZL} | Output Enable Time | 3.3 | 1.5 | 5.0 | 8.0 | 1.0 | 9.0 | ns |
| | | 5.0 | 1.5 | 3.5 | 6.0 | 1.0 | 7.0 | |
| t _{PHZ} | Output Disable Time | 3.3 | 2.0 | 5.5 | 9.5 | 1.5 | 10.0 | ns |
| | | 5.0 | 2.0 | 5.0 | 8.0 | 1.5 | 8.5 | |
| t _{PLZ} | Output Disable Time | 3.3 | 1.5 | 5.0 | 8.0 | 1.0 | 9.0 | ns |
| | | 5.0 | 1.5 | 4.0 | 7.0 | 1.0 | 7.5 | |
| <p>Note 7: Voltage Range 3.3 is 3.3V ± 0.3V Voltage Range 5.0 is 5.0V ± 0.5V</p> | | | | | | | | |

AC Electrical Characteristics for ACT

| Symbol | Parameter | V _{CC} (V) (Note 8) | T _A = +25°C C _L = 50 pF | | | T _A = -40°C to +85°C C _L = 50 pF | | Units |
|------------------|---|------------------------------------|--|-----|------|---|------|-------|
| | | | Min | Typ | Max | Min | Max | |
| t _{PLH} | Propagation Delay S _n to Z _n | 5.0 | 2.0 | 7.0 | 11.5 | 2.0 | 13.0 | ns |
| t _{PHL} | Propagation Delay S _n to Z _n | 5.0 | 3.0 | 7.5 | 13.0 | 2.5 | 14.5 | ns |
| t _{PLH} | Propagation Delay I _n to Z _n | 5.0 | 2.5 | 5.5 | 10.0 | 2.0 | 11.0 | ns |
| t _{PHL} | Propagation Delay I _n to Z _n | 5.0 | 3.5 | 6.5 | 11.0 | 3.0 | 12.5 | ns |
| t _{PZH} | Output Enable Time | 5.0 | 2.0 | 4.5 | 7.5 | 1.5 | 8.5 | ns |
| t _{PZL} | Output Enable Time | 5.0 | 2.0 | 5.0 | 8.0 | 1.5 | 9.0 | ns |
| t _{PHZ} | Output Disable Time | 5.0 | 3.0 | 6.0 | 9.5 | 2.5 | 10.0 | ns |
| t _{PLZ} | Output Disable Time | 5.0 | 2.5 | 4.5 | 7.5 | 2.0 | 8.5 | ns |

Note 8: Voltage Range 5.0 is 5.0V ± 0.5V

Capacitance

| Symbol | Parameter | Typ | Units | Conditions |
|-----------------|-------------------------------|------|-------|------------------------|
| C _{IN} | Input Capacitance | 4.5 | pF | V _{CC} = OPEN |
| C _{PD} | Power Dissipation Capacitance | 50.0 | pF | V _{CC} = 5.0V |

Physical Dimensions inches (millimeters) unless otherwise noted

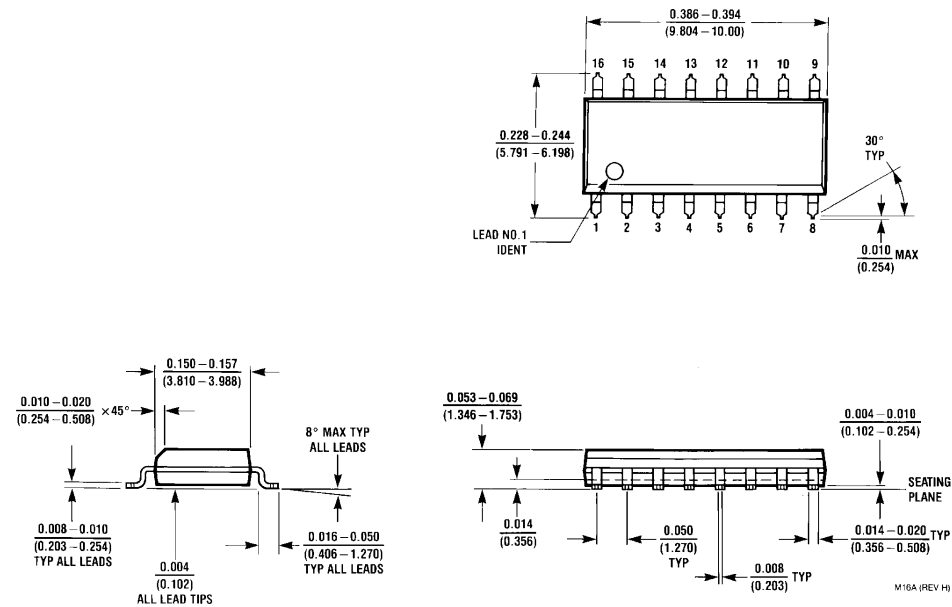

16-Lead Small Outline Integrated Circuit (SOIC), JEDEC MS-012, 0.150" Narrow Body Package Number M16A

Physical Dimensions inches (millimeters) unless otherwise noted (Continued)

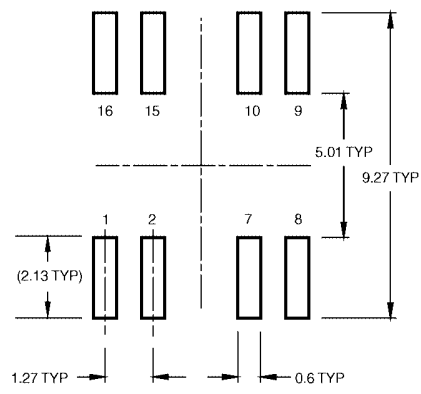
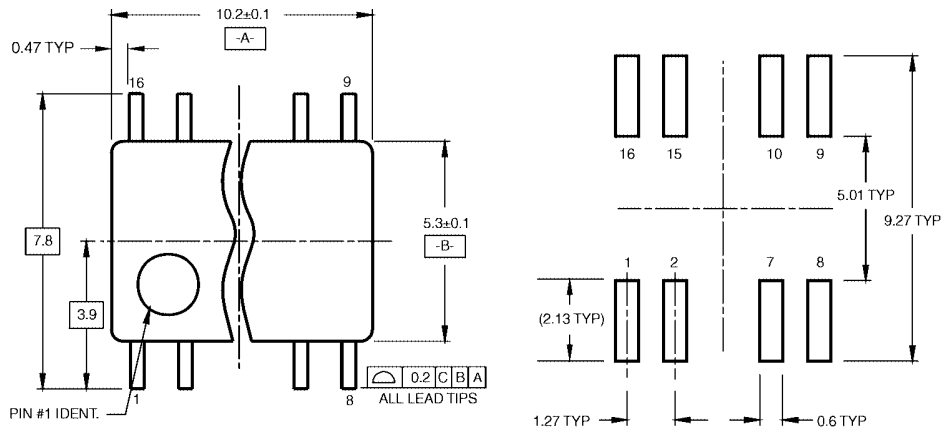

LAND PATTERN RECOMMENDATION

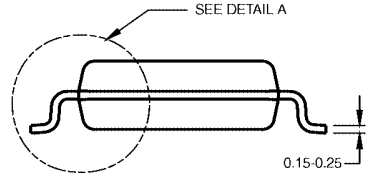
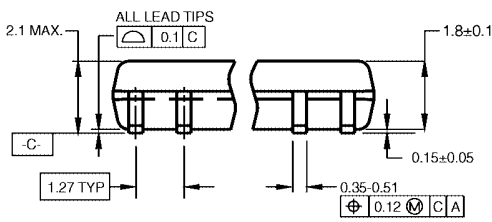

DIMENSIONS ARE IN MILLIMETERS

- NOTES:
 A. CONFORMS TO EIAJ EDR-7320 REGISTRATION, ESTABLISHED IN DECEMBER, 1998.
 B. DIMENSIONS ARE IN MILLIMETERS.
 C. DIMENSIONS ARE EXCLUSIVE OF BURRS, MOLD FLASH, AND TIE BAR EXTRUSIONS.

M16DRevB1

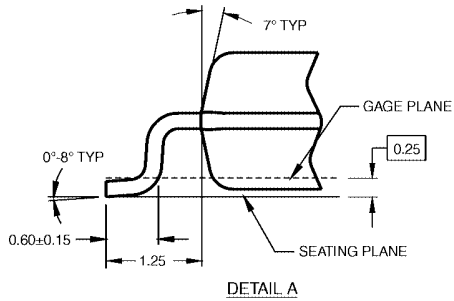

**16-Lead Small Outline Package (SOP), EIAJ TYPE II, 5.3mm Wide
 Package Number M16D**

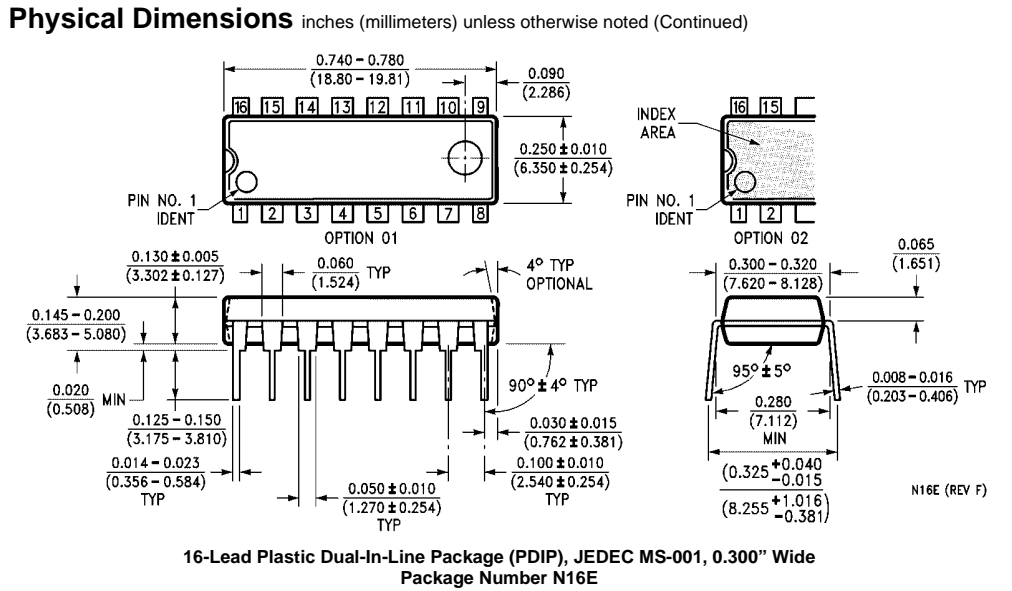

Fairchild does not assume any responsibility for use of any circuitry described, no circuit patent licenses are implied and Fairchild reserves the right at any time without notice to change said circuitry and specifications.

LIFE SUPPORT POLICY

FAIRCHILD'S PRODUCTS ARE NOT AUTHORIZED FOR USE AS CRITICAL COMPONENTS IN LIFE SUPPORT DEVICES OR SYSTEMS WITHOUT THE EXPRESS WRITTEN APPROVAL OF THE PRESIDENT OF FAIRCHILD SEMICONDUCTOR CORPORATION. As used herein:

1. Life support devices or systems are devices or systems which, (a) are intended for surgical implant into the body, or (b) support or sustain life, and (c) whose failure to perform when properly used in accordance with instructions for use provided in the labeling, can be reasonably expected to result in a significant injury to the user.
2. A critical component in any component of a life support device or system whose failure to perform can be reasonably expected to cause the failure of the life support device or system, or to affect its safety or effectiveness.

www.fairchildsemi.com