

74AC520 • 74ACT520 8-Bit Identity Comparator

General Description

The AC/ACT520 are expandable 8-bit comparators. They compare two words of up to eight bits each and provide a LOW output when the two words match bit for bit. The expansion input $I_{A=B}$ also serves as an active LOW enable input.

Features

- Compares two 8-bit words in 6.5 ns typ
- Expandable to any word length
- 20-pin package
- Outputs source/sink 24 mA
- ACT520 has TTL-compatible inputs

Ordering Code:

Order Number	Package Number	Package Description
74AC520SC	M20B	20-Lead Small Outline Integrated Circuit (SOIC), JEDEC MS-013, 0.300" Wide Body
74AC520PC	N20A	20-Lead Plastic Dual-In-Line Package (PDIP), JEDEC MS-001, 0.300" Wide
74ACT520SC	M20B	20-Lead Small Outline Integrated Circuit (SOIC), JEDEC MS-013, 0.300" Wide Body
74ACT520SJ	M20D	20-Lead Small Outline Package (SOP), EIAJ TYPE II, 5.3mm Wide
74ACT520PC	N20A	20-Lead Plastic Dual-In-Line Package (PDIP), JEDEC MS-001, 0.300" Wide

Device also available in Tape and Reel. Specify by appending suffix letter "X" to the ordering code.

Logic Symbols

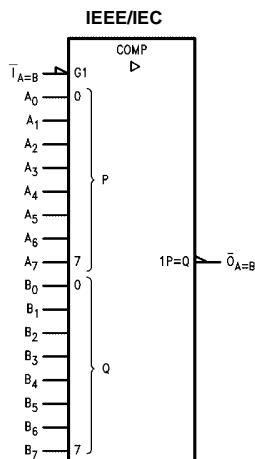
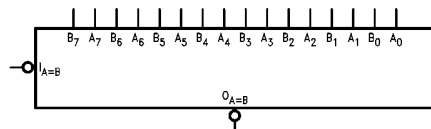

Connection Diagram

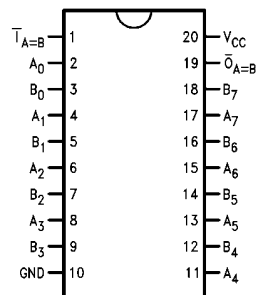

Pin Descriptions

Pin Names	Description
A ₀ -A ₇	Word A Inputs
B ₀ -B ₇	Word B Inputs
$\bar{I}_{A=B}$	Expansion or Enable Input
$\bar{O}_{A=B}$	Identity Output

FACT™ is a trademark of Fairchild Semiconductor Corporation.

Truth Table

Inputs		Outputs
$\bar{I}_{A=B}$	A, B	$\bar{O}_{A=B}$
L	A = B (Note 1)	L
L	A \neq B	H
H	A = B (Note 1)	H
H	A \neq B	H

H = HIGH Voltage Level

L = LOW Voltage Level

Note 1: *A₀ = B₀, A₁ = B₁, A₂ = B₂, etc.

Logic Diagram

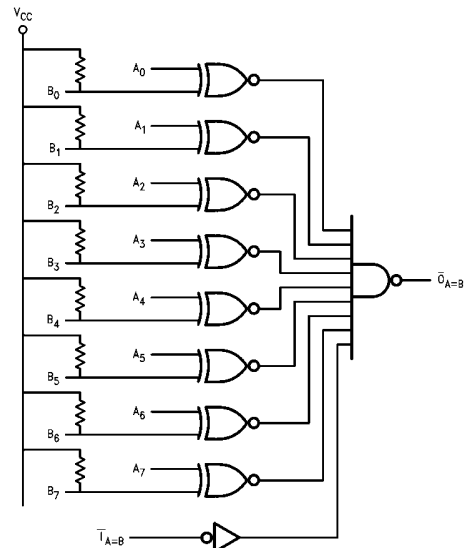

Please note that this diagram is provided only for the understanding of logic operations and should not be used to estimate propagation delays.

Applications

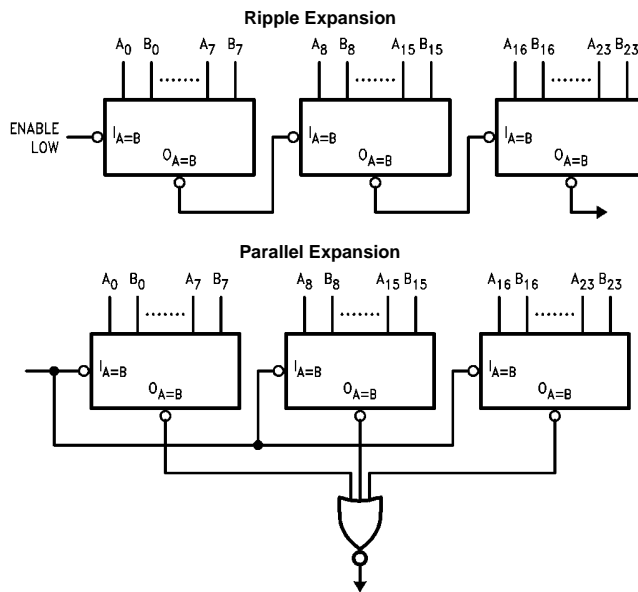

Absolute Maximum Ratings (Note 2)		Recommended Operating Conditions						
Supply Voltage (V_{CC})	-0.5V to +7.0V	Supply Voltage (V_{CC})	AC 2.0V to 6.0V					
DC Input Diode Current (I_{IK})		ACT 4.5V to 5.5V						
$V_I = -0.5V$	-20 mA	Input Voltage (V_I)	0V to V_{CC}					
$V_I = V_{CC} + 0.5V$	+20 mA	Output Voltage (V_O)	0V to V_{CC}					
DC Input Voltage (V_I)	-0.5V to $V_{CC} + 0.5V$	Operating Temperature (T_A)	-40°C to +85°C					
DC Output Diode Current (I_{OK})		Minimum Input Edge Rate ($\Delta V/\Delta t$)						
$V_O = -0.5V$	-20 mA	AC Devices						
$V_O = V_{CC} + 0.5V$	+20 mA	V_{IN} from 30% to 70% of V_{CC}						
DC Output Voltage (V_O)	-0.5V to $V_{CC} + 0.5V$	V_{CC} @ 3.3V, 4.5V, 5.5V	125 mV/ns					
DC Output Source		Minimum Input Edge Rate ($\Delta V/\Delta t$)						
or Sink Current (I_O)	± 50 mA	ACT Devices						
DC V_{CC} or Ground Current		V_{IN} from 0.8V to 2.0V						
per Output Pin (I_{CC} or I_{GND})	± 50 mA	V_{CC} @ 4.5V, 5.5V	125 mV/ns					
Storage Temperature (T_{STG})	-65°C to +150°C	Note 2: Absolute maximum ratings are those values beyond which damage to the device may occur. The databook specifications should be met, without exception, to ensure that the system design is reliable over its power supply, temperature, and output/input loading variables. Fairchild does not recommend operation of FACT™ circuits outside databook specifications.						
Junction Temperature (T_J)								
PDIP	140°C							
DC Electrical Characteristics for AC								
Symbol	Parameter	V_{CC} (V)	$T_A = +25^\circ\text{C}$		$T_A = -40^\circ\text{C to } +85^\circ\text{C}$		Units	Conditions
			Typ	Guaranteed Limits				
V_{IH}	Minimum HIGH Level Input Voltage	3.0	1.5	2.1	2.1	V	$V_{OUT} = 0.1V$ or $V_{CC} - 0.1V$	
		4.5	2.25	3.15	3.15			
		5.5	2.75	3.85	3.85			
V_{IL}	Maximum LOW Level Input Voltage	3.0	1.5	0.9	0.9	V	$V_{OUT} = 0.1V$ or $V_{CC} - 0.1V$	
		4.5	2.25	1.35	1.35			
		5.5	2.75	1.65	1.65			
V_{OH}	Minimum HIGH Level Output Voltage	3.0	2.99	2.9	2.9	V	$I_{OUT} = -50 \mu A$	
		4.5	4.49	4.4	4.4			
		5.5	5.49	5.4	5.4			
			3.0		2.56	2.46	V	$V_{IN} = V_{IL}$ or V_{IH} $I_{OH} = -12$ mA $I_{OH} = -24$ mA $I_{OH} = -24$ mA (Note 3)
			4.5		3.86	3.76		
			5.5		4.86	4.76		
V_{OL}	Maximum LOW Level Output Voltage	3.0	0.002	0.1	0.1	V	$I_{OUT} = 50 \mu A$	
		4.5	0.001	0.1	0.1			
		5.5	0.001	0.1	0.1			
		3.0		0.36	0.44	V	$V_{IN} = V_{IL}$ or V_{IH} $I_{OL} = 12$ mA $I_{OL} = 24$ mA $I_{OL} = 24$ mA (Note 3)	
		4.5		0.36	0.44			
		5.5		0.36	0.44			
I_{IN} (Note 5)	Maximum Input Leakage Current	5.5		± 0.1	± 1.0	μA	$V_I = V_{CC}$, GND, A Inputs Only	
I_{IH}	Maximum Input HIGH Leakage Current	5.5		10.0	10.0	μA	$V_I = V_{CC}$, B Inputs Only	
I_{IL}	Maximum Input LOW Leakage Current	5.5	-0.3	-0.6	-1.0	mA	$V_I = V_{CC}$, B Inputs Only	
I_{OLD}	Minimum Dynamic	5.5			75	mA	$V_{OLD} = 1.65V$ Max	
I_{OHD}	Output Current (Note 4)	5.5			-75	mA	$V_{OHD} = 3.85V$ Min	
I_{CC}	Maximum Quiescent Supply Current	5.5		4.0	40.0	μA	$V_{IN} = V_{CC}$	
I_{CC} (Note 5)	Maximum Quiescent Supply Current	5.5	2.3	4.8	8.0	mA	$V_{IN} = GND$	
Note 3: All outputs loaded; thresholds on input associated with output under test.								
Note 4: Maximum test duration 2.0 ms, one output loaded at a time.								
Note 5: I_{IN} and I_{CC} @ 3.0V are guaranteed to be less than or equal to the respective limit @ 5.5V V_{CC} .								

DC Electrical Characteristics for ACT

Symbol	Parameter	V _{CC} (V)	T _A = +25°C		T _A = -40°C to +85°C	Units	Conditions	
			Typ	Guaranteed Limits				
V _{IH}	Minimum HIGH Level Input Voltage	4.5	1.5	2.0	2.0	V	V _{OUT} = 0.1V or V _{CC} - 0.1V	
		5.5	1.5	2.0	2.0			
V _{IL}	Maximum LOW Level Input Voltage	4.5	1.5	0.8	0.8	V	V _{OUT} = 0.1V or V _{CC} - 0.1V	
		5.5	1.5	0.8	0.8			
V _{OH}	Minimum HIGH Level Output Voltage	4.5	4.49	4.4	4.4	V	I _{OUT} = -50 μA	
		5.5	5.49	5.4	5.4			
			4.5		3.86	3.76	V	V _{IN} = V _{IL} or V _{IH} I _{OH} = -24 mA I _{OH} = -24 mA (Note 6)
			5.5		4.86	4.76		
V _{OL}	Maximum LOW Level Output Voltage	4.5	0.001	0.1	0.1	V	I _{OUT} = 50 μA	
		5.5	0.001	0.1	0.1			
			4.5		0.36	0.44	V	V _{IN} = V _{IL} or V _{IH} I _{OL} = 24 mA I _{OL} = 24 mA (Note 6)
			5.5		0.36	0.44		
I _{IN}	Maximum Input Leakage Current	5.5		±0.1	±1.0	μA	V _I = V _{CC} , GND	
I _{IH}	Maximum Input HIGH Leakage Current	5.5		10.0	10.0	μA	V _I = V _{CC} B Inputs Only	
I _{IL}	Maximum Input LOW Leakage Current	5.5	-0.3	-0.6	-1.0	mA	V _I = V _{CC} B Inputs Only	
I _{CCT}	Maximum I _{CC} /Input	5.5	0.6		1.5	mA	V _I = V _{CC} - 2.1V	
I _{OLD}	Minimum Dynamic	5.5			75	mA	V _{OLD} = 1.65V Max	
I _{OHD}	Output Current (Note 7)	5.5			-75	mA	V _{OHD} = 3.85V Min	
I _{CC}	Maximum Quiescent Supply Current	5.5		4.0	40.0	μA	V _{IN} = V _{CC} or GND	
I _{CC}	Maximum Quiescent Supply Current	5.5	2.3	4.8	8.0	mA	V _{IN} = GND	

Note 6: All outputs loaded; thresholds on input associated with output under test.

Note 7: Maximum test duration 2.0 ms, one output loaded at a time.

AC Electrical Characteristics for AC								
Symbol	Parameter	V _{CC} (V) (Note 8)	T _A = +25°C C _L = 50 pF			T _A = -40°C to +85°C C _L = 50 pF		Units
			Min	Typ	Max	Min	Max	
t _{PLH}	Propagation Delay A _n or B _n to $\overline{O}_{A=B}$	3.3	4.0	7.5	11.5	3.0	13.0	ns
		5.0	2.5	5.5	8.5	2.0	9.5	
t _{PHL}	Propagation Delay A _n or B _n to $\overline{O}_{A=B}$	3.3	4.5	8.0	12.0	3.5	13.5	ns
		5.0	3.0	5.5	9.0	2.5	10.0	
t _{PLH}	Propagation Delay $\overline{I}_{A=B}$ to $\overline{O}_{A=B}$	3.3	3.5	5.5	8.5	2.5	9.5	ns
		5.0	2.5	4.5	6.5	2.0	7.0	
t _{PHL}	Propagation Delay $\overline{I}_{A=B}$ to $\overline{O}_{A=B}$	3.3	3.5	5.5	8.5	2.5	9.5	ns
		5.0	2.5	4.5	6.5	2.0	7.0	
Note 8: Voltage Range 3.3 is 3.3V ± 0.3V Voltage Range 5.0 is 5.0V ± 0.5V								
AC Electrical Characteristics for ACT								
Symbol	Parameter	V _{CC} (V) (Note 9)	T _A = +25°C C _L = 50 pF			T _A = -40°C to +85°C C _L = 50 pF		Units
			Min	Typ	Max	Min	Max	
t _{PLH}	Propagation Delay A _n or B _n to $\overline{O}_{A=B}$	5.0	3.0	5.5	8.5	2.5	9.5	ns
		5.0	3.0	6.0	10.0	2.5	11.5	
t _{PHL}	Propagation Delay A _n or B _n to $\overline{O}_{A=B}$	5.0	3.0	6.0	10.0	2.5	11.5	ns
		5.0	3.0	6.0	10.0	2.5	11.5	
t _{PLH}	Propagation Delay $\overline{I}_{A=B}$ to $\overline{O}_{A=B}$	5.0	2.0	4.0	6.0	2.0	6.5	ns
		5.0	2.0	4.0	6.0	2.0	6.5	
t _{PHL}	Propagation Delay $\overline{I}_{A=B}$ to $\overline{O}_{A=B}$	5.0	2.5	5.0	7.5	2.0	8.5	ns
		5.0	2.5	5.0	7.5	2.0	8.5	
Note 9: Voltage Range 5.0 is 5.0V ± 0.5V								
Capacitance								
Symbol	Parameter	Typ	Units	Conditions				
C _{IN}	Input Capacitance	4.5	pF	V _{CC} = OPEN				
C _{PD}	Power Dissipation Capacitance	40	pF	V _{CC} = 5.0V				

Physical Dimensions inches (millimeters) unless otherwise noted

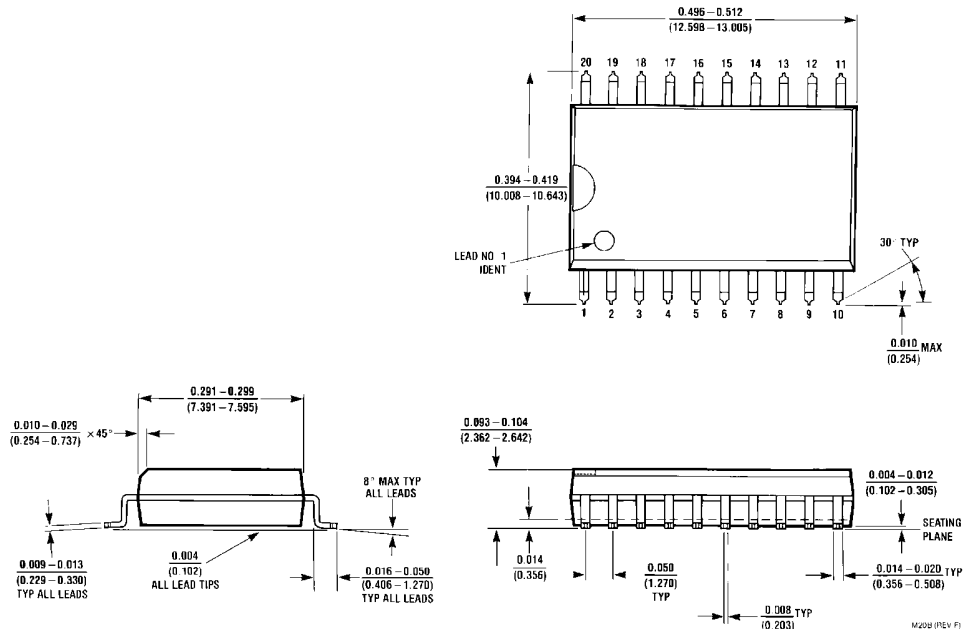

**20-Lead Small Outline Integrated Circuit (SOIC), JEDEC MS-013, 0.300" Wide Body
Package Number M20B**

Physical Dimensions inches (millimeters) unless otherwise noted (Continued)

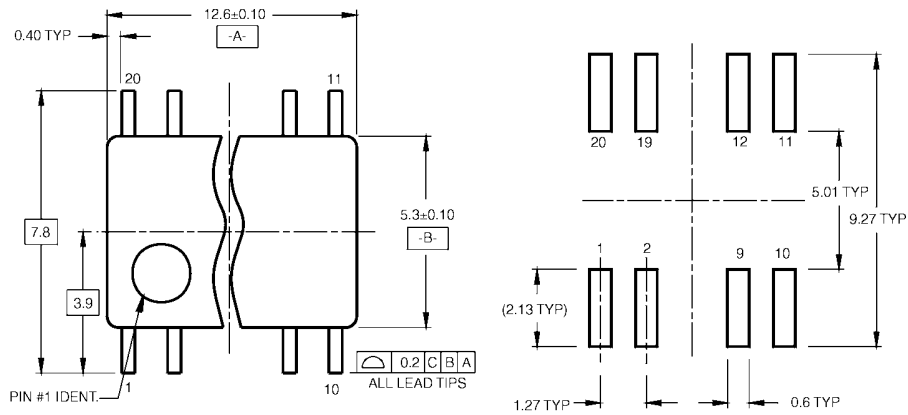

LAND PATTERN RECOMMENDATION

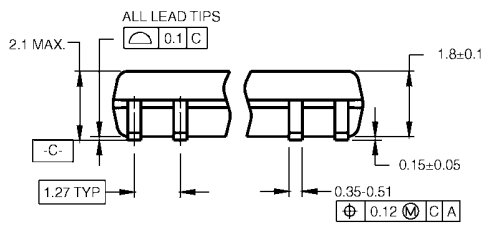

DIMENSIONS ARE IN MILLIMETERS

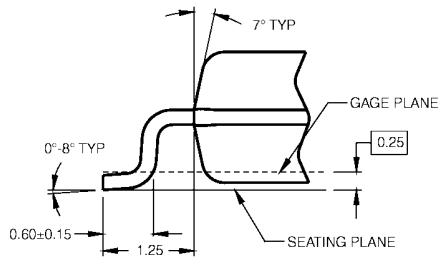
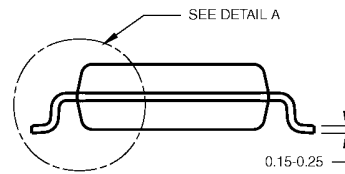

DETAIL A

- NOTES:
 A. CONFORMS TO EIAJ EDR-7320 REGISTRATION, ESTABLISHED IN DECEMBER, 1998.
 B. DIMENSIONS ARE IN MILLIMETERS.
 C. DIMENSIONS ARE EXCLUSIVE OF BURRS, MOLD FLASH, AND TIE BAR EXTRUSIONS.

M20DRevB1

**20-Lead Small Outline Package (SOP), EIAJ TYPE II, 5.3mm Wide
 Package Number M20D**

