

74VHCT138A 3-to-8 Decoder/Demultiplexer

General Description

The VHCT138A is an advanced high speed CMOS 3-to-8 DECODER fabricated with silicon gate CMOS technology. It achieves the high speed operation similar to equivalent Bipolar Schottky TTL while maintaining the CMOS low power dissipation.

When the device is enabled, 3 Binary Select inputs (A_0 , A_1 and A_2) determine which one of the outputs (\overline{O}_0 – \overline{O}_7) will go LOW. When enable input E_3 is held LOW or either \overline{E}_1 or \overline{E}_2 is held HIGH, decoding function is inhibited and all outputs go HIGH. E_3 , \overline{E}_1 and \overline{E}_2 inputs are provided to ease cascade connection and for use as an address decoder for memory systems. Protection circuits ensure that 0V to 7V can be applied to the input pins without regard to the sup-

ply voltage and to the output pins with $V_{CC} = 0V$. These circuits prevent device destruction due to mismatched supply and input/output voltages. This device can be used to interface 3V to 5V systems and two supply systems such as battery backup.

Features

- High Speed: $t_{PD} = 7.6$ ns (typ) at $V_{CC} = 5V$
- Low power dissipation: $I_{CC} = 4$ μA (max.) at $T_A = 25^\circ C$
- Power down protection is provided on all inputs and outputs
- Pin and function compatible with 74HCT138

Ordering Code:

Order Number	Package Number	Package Description
74VHCT138AM	M16A	16-Lead Small Outline Integrated Circuit (SOIC), JEDEC MS-012, 0.150 Narrow
74VHCT138ASJ	M16D	16-Lead Small Outline Package (SOP), EIAJ TYPE II, 5.3mm Wide
74VHCT138AMTC	MTC16	16-Lead Thin Shrink Small Outline Package (TSSOP), JEDEC MO-153, 4.4mm Wide
74VHCT138AN	N16E	16-Lead Plastic Dual-In-Line Package (PDIP), JEDEC MS-001, 0.300 Wide

Surface mount packages are also available on Tape and Reel. Specify by appending the suffix letter "X" to the ordering code.

Logic Symbols

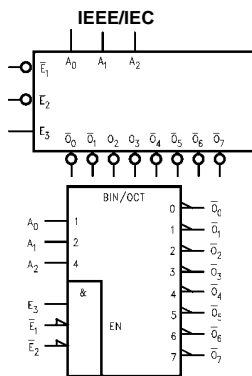

Connection Diagram

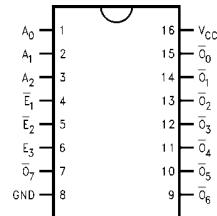

Pin Descriptions

Pin Names	Description
A_0 – A_2	Address Inputs
\overline{E}_1 – \overline{E}_2	Enable Inputs
E_3	Enable Input
\overline{O}_0 – \overline{O}_7	Outputs

Truth Table

Inputs						Outputs							
\bar{E}_1	\bar{E}_2	E_3	A_0	A_1	A_2	\bar{O}_0	\bar{O}_1	\bar{O}_2	\bar{O}_3	\bar{O}_4	\bar{O}_5	\bar{O}_6	\bar{O}_7
H	X	X	X	X	X	H	H	H	H	H	H	H	H
X	H	X	X	X	X	H	H	H	H	H	H	H	H
X	X	L	X	X	X	H	H	H	H	H	H	H	H
L	L	H	L	L	L	L	H	H	H	H	H	H	H
L	L	H	H	L	L	H	L	H	H	H	H	H	H
L	L	H	L	H	L	H	H	L	H	H	H	H	H
L	L	H	H	H	L	H	H	H	L	H	H	H	H
L	L	H	L	L	H	H	H	H	H	L	H	H	H
L	L	H	H	L	H	H	H	H	H	H	L	H	H
L	L	H	L	H	H	H	H	H	H	H	H	L	H
L	L	H	H	H	H	H	H	H	H	H	H	H	L

H = HIGH Voltage Level
 L = LOW Voltage Level
 X = Immaterial

Logic Diagram

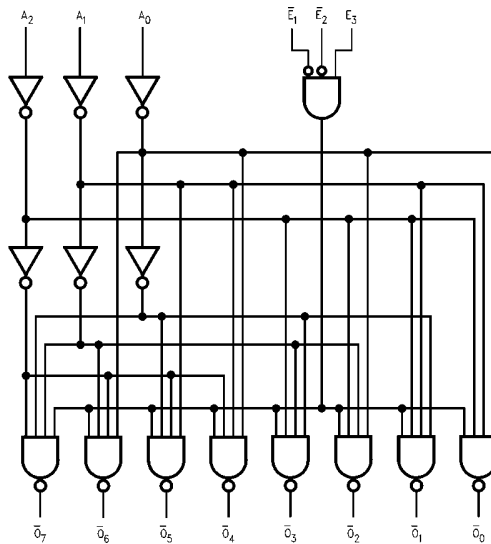

Please note that this diagram is provided only for the understanding of logic operations and should not be used to estimate propagation delays.

Absolute Maximum Ratings (Note 1)		Recommended Operating Conditions (Note 5)	
Supply Voltage (V_{CC})	-0.5V to +7.0V	Supply Voltage (V_{CC})	4.5V to +5.5V
DC Input Voltage (V_{IN})	-0.5V to +7.0V	Input Voltage (V_{IN})	0V to +5.5V
DC Output Voltage (V_{OUT})	-0.5V to 7.0V	Output Voltage (V_{OUT})	0V to V_{CC}
(Note 2)	-0.5V to $V_{CC} + 0.5V$	(Note 3)	0V to 5.5V
Input Diode Current (I_{IK})	-20 mA	(Note 2)	0V to 5.5V
Output Diode Current (I_{OK})	±20 mA	Operating Temperature (T_{OPR})	-40°C to +85°C
(Note 4)	±25 mA	Input Rise and Fall Time (t_r, t_f)	0 ~ 20 ns/V
DC Output Current (I_{OUT})	±75 mA	$V_{CC} = 5.0V \pm 0.5V$	
DC V_{CC}/GND Current (I_{CC})	±75 mA	Note 1: Absolute Maximum Ratings are values beyond which the device may be damaged or have its useful life impaired. The databook specifications should be met, without exception, to ensure that the system design is reliable over its power supply, temperature, and output/input loading variables. Fairchild does not recommend operation outside databook specifications.	
Storage Temperature (T_{STG})	-65°C to +150°C	Note 2: $V_{CC} = 0V$.	
Lead Temperature (T_L)	260°C	Note 3: HIGH or LOW state. I_{OUT} absolute maximum rating must be observed.	
(Soldering, 10 seconds)		Note 4: $V_{OUT} < GND, V_{OUT} > V_{CC}$ (Outputs Active).	
		Note 5: Unused inputs must be held HIGH or LOW. They may not float.	

DC Electrical Characteristics

Symbol	Parameter	V_{CC} (V)	$T_A = 25^\circ C$			$T_A = -40^\circ C$ to $+85^\circ C$		Units	Conditions	
			Min	Typ	Max	Min	Max			
V_{IH}	HIGH Level Input Voltage	4.5 – 5.5	2.0			2.0		V		
V_{IL}	LOW Level Input Voltage	4.5 – 5.5			0.8		0.8	V		
V_{OH}	HIGH Level	4.5	4.4	4.5		4.4		V	$V_{IN} = V_{IH}$ or V_{IL}	$I_{OH} = -50 \mu A$
	Output Voltage	4.5	3.94			3.80				$I_{OH} = -8 mA$
V_{OL}	LOW Level	4.5		0.0	0.1		0.1	V	$V_{IN} = V_{IH}$ or V_{IL}	$I_{OL} = 50 \mu A$
	Output Voltage	4.5			0.36		0.44			$I_{OL} = 8 mA$
I_{IN}	Input Leakage Current	0 – 5.5			±0.1		±1.0	μA	$V_{IN} = 5.5V$ or GND	
I_{CC}	Quiescent Supply Current	5.5			4.0		20.0	μA	$V_{IN} = V_{CC}$ or GND	
I_{CCT}	Maximum $I_{CC}/Input$	5.5			1.35		1.50	mA	$V_{in} = 3.4V$ other inputs = V_{CC} or GND	
I_{OFF}	Output Leakage Current	0			0.5		5.0	μA	$V_{OUT} = 5.5V$	

AC Electrical Characteristics

Symbol	Parameter	V_{CC} (V)	$T_A = 25^\circ C$			$T_A = -40^\circ C$ to $+85^\circ C$		Units	Conditions
			Min	Typ	Max	Min	Max		
t_{PLH}	Propagation Delay	5.0 ± 0.5		7.6	10.4	1.0	12.0	ns	$C_L = 15 pF$ $C_L = 50 pF$
t_{PHL}	A_n to \bar{O}_n			8.1	11.4	1.0	13.0		
t_{PLH}	Propagation Delay	5.0 ± 0.5		6.6	9.1	1.0	10.5	ns	$C_L = 15 pF$ $C_L = 50 pF$
t_{PHL}	E_3 to \bar{O}_n			7.1	10.1	1.0	11.5		
t_{PLH}	Propagation Delay	5.0 ± 0.5		7.0	9.6	1.0	11.0	ns	$C_L = 15 pF$ $C_L = 50 pF$
t_{PHL}	\bar{E}_1 or E_2 to \bar{O}_n			7.5	10.6	1.0	12.0		
C_{IN}	Input Capacitance			4	10		10	pF	$V_{CC} = Open$
C_{PD}	Power Dissipation Capacitance			49				pF	(Note 6)

Note 6: C_{PD} is defined as the value of the internal equivalent capacitance which is calculated from the operating current consumption without load. Average operating current can be obtained by the equation: $I_{CC} (opr.) = C_{PD} * V_{CC} * f_{IN} + I_{CC}$.

Physical Dimensions inches (millimeters) unless otherwise noted

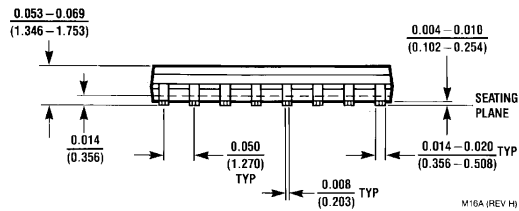
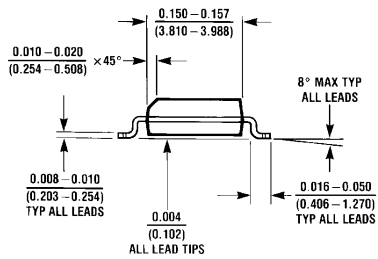
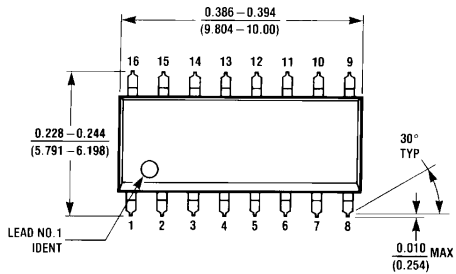

16-Lead Small Outline Integrated Circuit (SOIC), JEDEC MS-012, 0.150 Narrow Package Number M16A

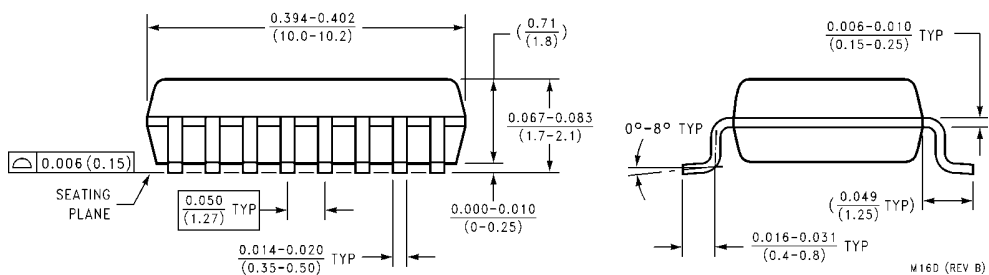
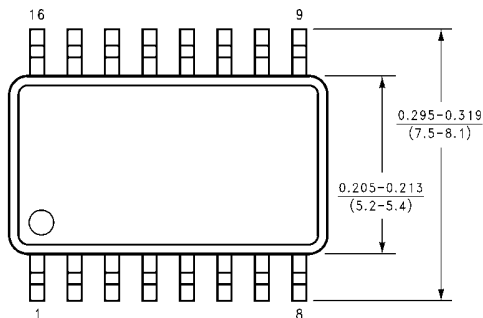

16-Lead Small Outline Package (SOP), EIAJ TYPE II, 5.3mm Wide Package Number M16D

Physical Dimensions inches (millimeters) unless otherwise noted (Continued)

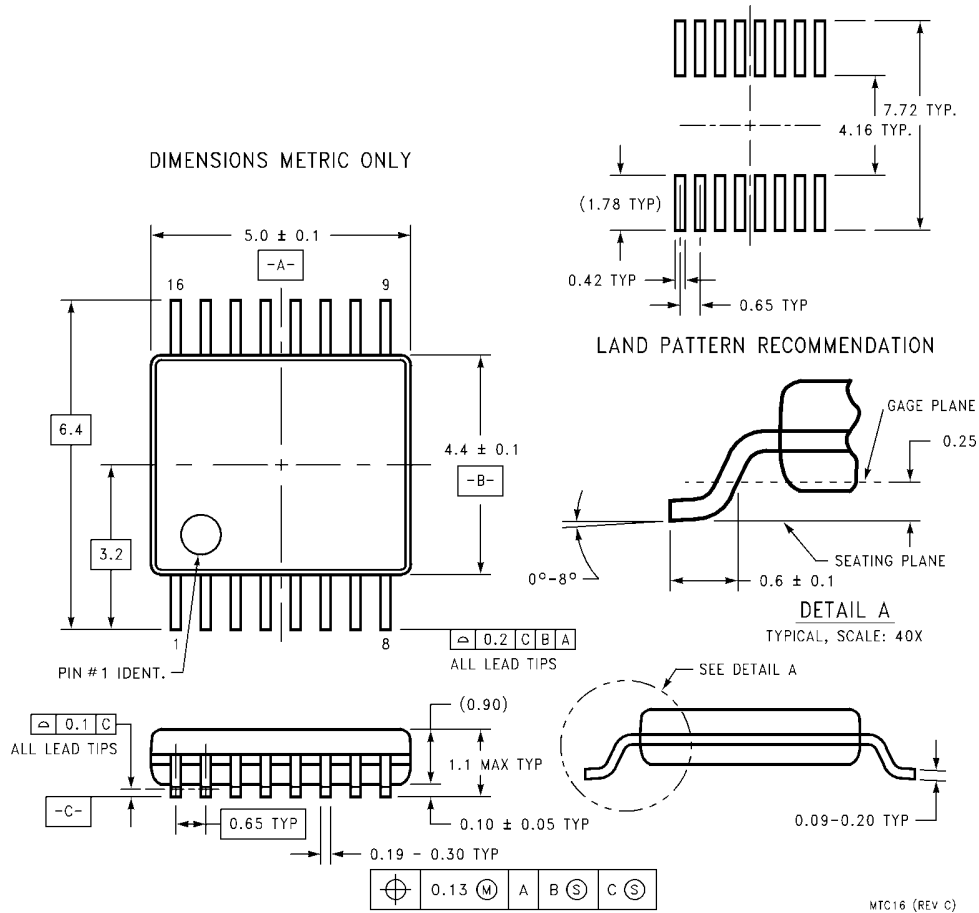

**16-Lead Thin Shrink Small Outline Package (TSSOP), JEDEC MO-153, 4.4mm Wide
Package Number MTC16**

MTC16 (REV C)

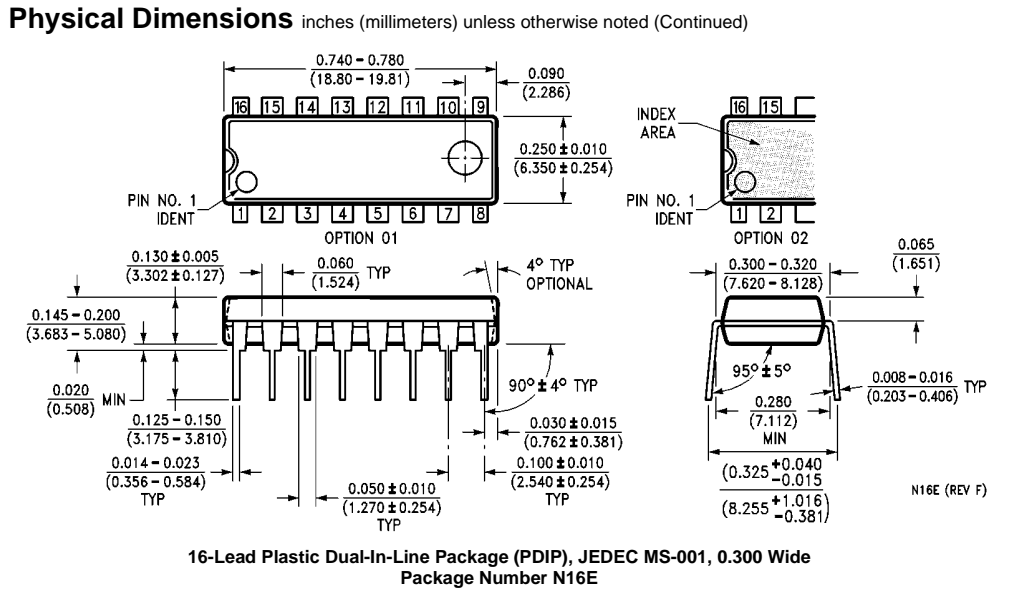

LIFE SUPPORT POLICY

FAIRCHILD'S PRODUCTS ARE NOT AUTHORIZED FOR USE AS CRITICAL COMPONENTS IN LIFE SUPPORT DEVICES OR SYSTEMS WITHOUT THE EXPRESS WRITTEN APPROVAL OF THE PRESIDENT OF FAIRCHILD SEMICONDUCTOR CORPORATION. As used herein:

1. Life support devices or systems are devices or systems which, (a) are intended for surgical implant into the body, or (b) support or sustain life, and (c) whose failure to perform when properly used in accordance with instructions for use provided in the labeling, can be reasonably expected to result in a significant injury to the user.
2. A critical component in any component of a life support device or system whose failure to perform can be reasonably expected to cause the failure of the life support device or system, or to affect its safety or effectiveness.

www.fairchildsemi.com

Fairchild does not assume any responsibility for use of any circuitry described, no circuit patent licenses are implied and Fairchild reserves the right at any time without notice to change said circuitry and specifications.