

CD4017BC • CD4022BC

Decade Counter/Divider with 10 Decoded Outputs • Divide-by-8 Counter/Divider with 8 Decoded Outputs

General Description

The CD4017BC is a 5-stage divide-by-10 Johnson counter with 10 decoded outputs and a carry out bit.

The CD4022BC is a 4-stage divide-by-8 Johnson counter with 8 decoded outputs and a carry-out bit.

These counters are cleared to their zero count by a logical "1" on their reset line. These counters are advanced on the positive edge of the clock signal when the clock enable signal is in the logical "0" state.

The configuration of the CD4017BC and CD4022BC permits medium speed operation and assures a hazard free counting sequence. The 10/8 decoded outputs are normally in the logical "0" state and go to the logical "1" state only at their respective time slot. Each decoded output remains high for 1 full clock cycle. The carry-out signal completes a full cycle for every 10/8 clock input cycles and is used as a ripple carry signal to any succeeding stages.

Features

- Wide supply voltage range: 3.0V to 15V
- High noise immunity: $0.45 V_{DD}$ (typ.)
- Low power Fan out of 2 driving 74L
TTL compatibility: or 1 driving 74LS
- Medium speed operation: 5.0 MHz (typ.)
with 10V V_{DD}
- Low power: 10 μ W (typ.)
- Fully static operation

Applications

- Automotive
- Instrumentation
- Medical electronics
- Alarm systems
- Industrial electronics
- Remote metering

Ordering Code:

Order Number	Package Number	Package Description
CD4017BCM	M16A	16-Lead Small Outline Integrated Circuit (SOIC), JEDEC MS-012, 0.150" Narrow
CD4017BCSJ	M16D	16-Lead Small Outline Package (SOP), EIAJ TYPE II, 5.3mm Wide
CD4017BCN	N16E	16-Lead Plastic Dual-In-Line Package (PDIP), JEDEC MS-001, 0.300" Wide
CD4022BCM	M16A	16-Lead Small Outline Integrated Circuit (SOIC), JEDEC MS-012, 0.150" Narrow
CD4022BCN	N16E	16-Lead Plastic Dual-In-Line Package (PDIP), JEDEC MS-001, 0.300" Wide

Devices also available in Tape and Reel. Specify by appending the suffix letter "X" to the ordering code.

Connection Diagrams

Pin Assignments for DIP, SOIC and SOP
CD4017B

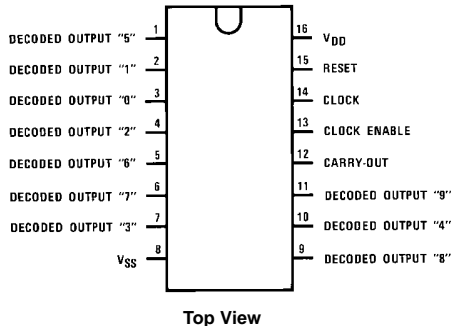

Pin Assignments for DIP and SOIC
CD4022B

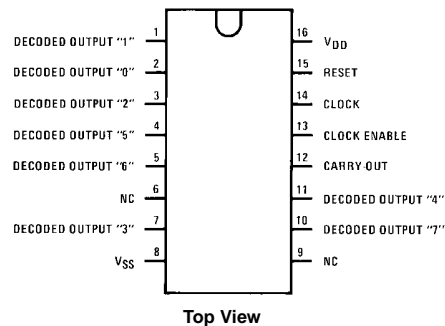

Logic Diagrams

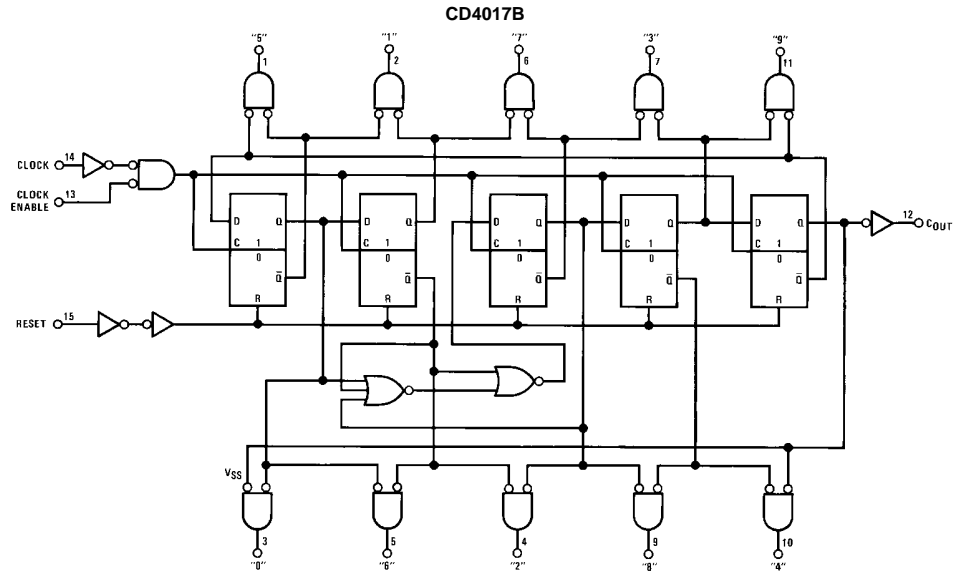

Terminal No. 8 = GND
Terminal No. 16 = V_{DD}

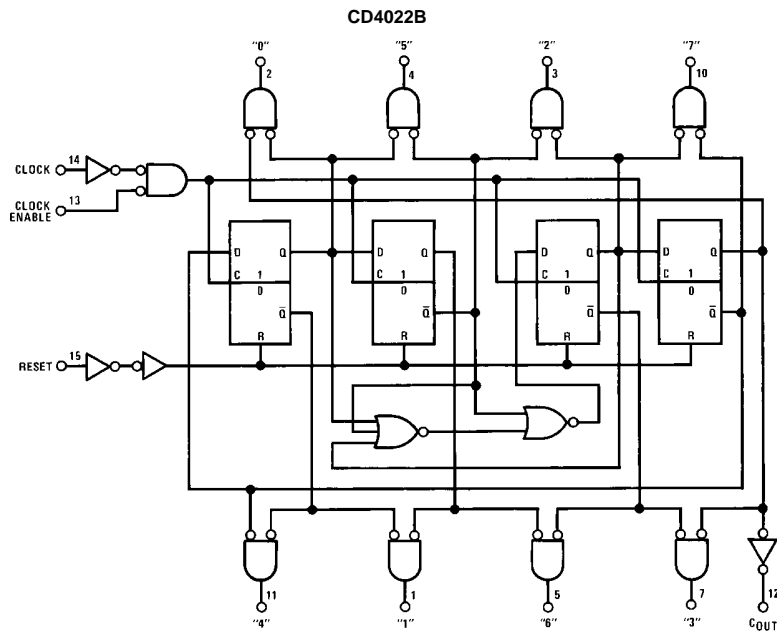

Terminal No. 16 = V_{DD}
Terminal No. 8 = GND

Absolute Maximum Ratings (Note 1)		Recommended Operating Conditions (Note 2)	
DC Supply Voltage (V_{DD})	-0.5 V_{DC} to +18 V_{DC}	DC Supply Voltage (V_{DD})	+3 V_{DC} to +15 V_{DC}
Input Voltage (V_{IN})	-0.5 V_{DC} to V_{DD} +0.5 V_{DC}	Input Voltage (V_{IN})	0 to V_{DD} V_{DC}
Storage Temperature (T_S)	-65°C to +150°C	Operating Temperature Range (T_A)	-40°C to +85°C
Power Dissipation (P_D)		Note 1: "Absolute Maximum Ratings" are those values beyond which the safety of the device cannot be guaranteed, they are not meant to imply that the devices should be operated at these limits. The table of "Recommended Operating Conditions" and "Electrical Characteristics" provides conditions for actual device operation.	
Dual-In-Line	700 mW	Note 2: $V_{SS} = 0V$ unless otherwise specified.	
Small Outline	500 mW		
Lead Temperature (T_L)			
(Soldering, 10 seconds)	260°C		

DC Electrical Characteristics (Note 2)

Symbol	Parameter	Conditions	-40°C		+25°			+85°C		Units
			Min	Max	Min	Typ	Max	Min	Max	
I_{DD}	Quiescent Device Current	$V_{DD} = 5V$		20		0.5	20		150	μA
		$V_{DD} = 10V$		40		1.0	40		300	μA
		$V_{DD} = 15V$		80		5.0	80		600	μA
V_{OL}	LOW Level Output Voltage	$ I_{OL} < 1.0 \mu A$								
		$V_{DD} = 5V$		0.05		0	0.05		0.05	V
		$V_{DD} = 10V$		0.05		0	0.05		0.05	V
		$V_{DD} = 15V$		0.05		0	0.05		0.05	V
V_{OH}	HIGH Level Output Voltage	$ I_{OL} < 1.0 \mu A$								
		$V_{DD} = 5V$	4.95		4.95	5		4.95		V
		$V_{DD} = 10V$	9.95		9.95	10		9.95		V
		$V_{DD} = 15V$	14.95		14.95	15		14.95		V
V_{IL}	LOW Level Input Voltage	$ I_{OL} < 1.0 \mu A$								
		$V_{DD} = 5V, V_O = 0.5V$ or 4.5V		1.5			1.5		1.5	V
		$V_{DD} = 10V, V_O = 1.0V$ or 9.0V		3.0			3.0		3.0	V
		$V_{DD} = 15V, V_O = 1.5V$ or 13.5V		4.0			4.0		4.0	V
V_{IH}	HIGH Level Input Voltage	$ I_{OL} < 1.0 \mu A$								
		$V_{DD} = 5V, V_O = 0.5V$ or 4.5V	3.5		3.5			3.5		V
		$V_{DD} = 10V, V_O = 1.0V$ or 9.0V	7.0		7.0			7.0		V
		$V_{DD} = 15V, V_O = 1.5V$ or 13.5V	11.0		11.0			11.0		V
I_{OL}	LOW Level Output Current (Note 3)	$V_{DD} = 5V, V_O = 0.4V$	0.52		0.44	0.88		0.36		mA
		$V_{DD} = 10V, V_O = 0.5V$	1.3		1.1	2.25		0.9		mA
		$V_{DD} = 15V, V_O = 1.5V$	3.6		3.0	8.8		2.4		mA
I_{OH}	HIGH Level Output Current (Note 3)	$V_{DD} = 5V, V_O = 4.6V$	-0.2		-0.16	-0.36		-0.12		mA
		$V_{DD} = 10V, V_O = 9.5V$	-0.5		-0.4	-0.9		-0.3		mA
		$V_{DD} = 15V, V_O = 13.5V$	-1.4		-1.2	-3.5		-1.0		mA
I_{IN}	Input Current	$V_{DD} = 15V, V_{IN} = 0V$		-0.3		-10^{-5}	-0.3		-1.0	μA
		$V_{DD} = 15V, V_{IN} = 15V$		0.3		10^{-5}	0.3		1.0	μA

Note 3: I_{OL} and I_{OH} are tested one output at a time.

AC Electrical Characteristics (Note 4)						
T _A = 25°C, C _L = 50 pF, R _L = 200k, t _{rCL} and t _{fCL} = 20 ns, unless otherwise specified						
Symbol	Parameter	Conditions	Min	Typ	Max	Units
CLOCK OPERATION						
t _{PHL} , t _{PLH}	Propagation Delay Time Carry Out Line	V _{DD} = 5V V _{DD} = 10V V _{DD} = 15V		415 160 130	800 320 250	ns ns ns
	Carry Out Line	V _{DD} = 5V V _{DD} = 10V V _{DD} = 15V	C _L = 15 pF	240 85 70	480 170 140	ns ns ns
	Decode Out Lines	V _{DD} = 5V V _{DD} = 10V V _{DD} = 15V		500 200 160	1000 400 320	ns ns ns
t _{TLH} , t _{THL}	Transition Time Carry Out and Decode Out Lines	V _{DD} = 5V V _{DD} = 10V V _{DD} = 15V		200 100 80	360 180 130	ns ns ns
	t _{TLH}	V _{DD} = 5V V _{DD} = 10V V _{DD} = 15V		100 50 40	200 100 80	ns ns ns
	t _{THL}	V _{DD} = 5V V _{DD} = 10V V _{DD} = 15V				
f _{CL}	Maximum Clock Frequency	V _{DD} = 5V V _{DD} = 10V V _{DD} = 15V	Measured with Respect to Carry Output Line	1.0 2.5 3.0	2 5 6	MHz MHz MHz
t _{WL} , t _{WH}	Minimum Clock Pulse Width	V _{DD} = 5V V _{DD} = 10V V _{DD} = 15V		125 45 35	250 90 70	ns ns ns
t _{rCL} , t _{fCL}	Clock Rise and Fall Time	V _{DD} = 5V V _{DD} = 10V V _{DD} = 15V			20 15 5	µs µs µs
t _{SU}	Minimum Clock Inhibit Data Setup Time	V _{DD} = 5V V _{DD} = 10V V _{DD} = 15V		120 40 32	240 80 65	ns ns ns
C _{IN}	Average Input Capacitance			5	7.5	pF
Note 4: AC Parameters are guaranteed by DC correlated testing.						
AC Electrical Characteristics (Note 4)						
T _A = 25°C, C _L = 50 pF, R _L = 200k, t _{rCL} and t _{fCL} = 20 ns, unless otherwise specified						
Symbol	Parameter	Conditions	Min	Typ	Max	Units
RESET OPERATION						
t _{PHL} , t _{PLH}	Propagation Delay Time Carry Out Line	V _{DD} = 5V V _{DD} = 10V V _{DD} = 15V		415 160 130	800 320 250	ns ns ns
	Carry Out Line	V _{DD} = 5V V _{DD} = 10V V _{DD} = 15V	C _L = 15 pF	240 85 70	480 170 140	ns ns ns
	Decode Out Lines	V _{DD} = 5V V _{DD} = 10V V _{DD} = 15V		500 200 160	1000 400 320	ns ns ns
t _W	Minimum Reset Pulse Width	V _{DD} = 5V V _{DD} = 10V V _{DD} = 15V		200 70 55	400 140 110	ns ns ns
	t _{REM}	Minimum Reset Removal Time	V _{DD} = 5V	75	150	ns
			V _{DD} = 10V	30	60	ns
		V _{DD} = 15V	25	50	ns	

Timing Diagrams

CD4017B

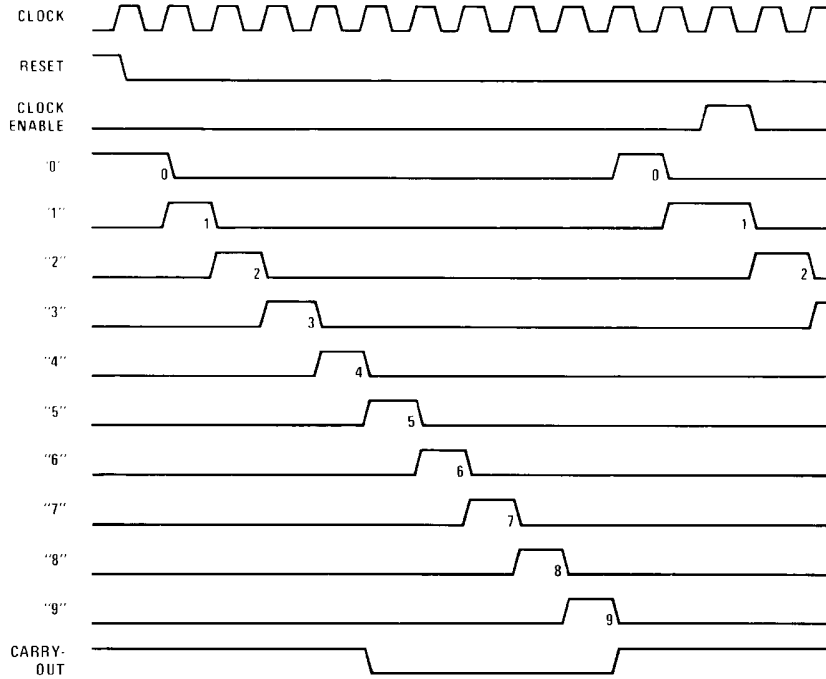

CD4022B

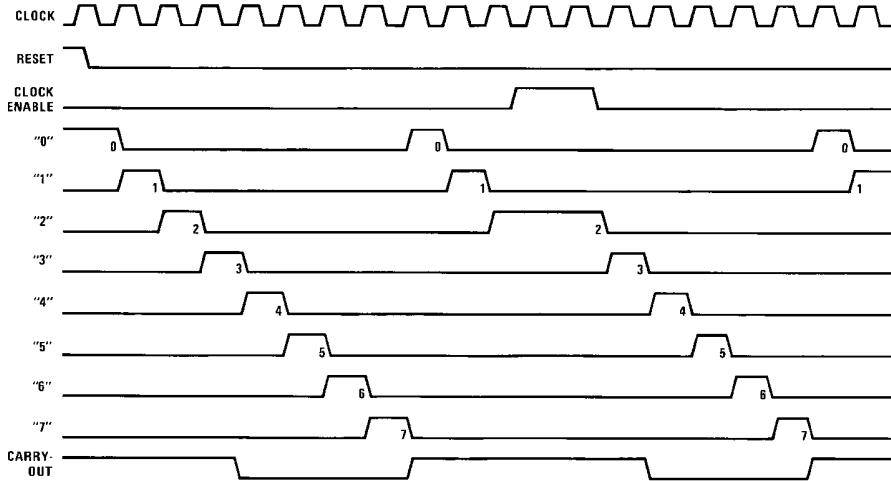

Physical Dimensions inches (millimeters) unless otherwise noted

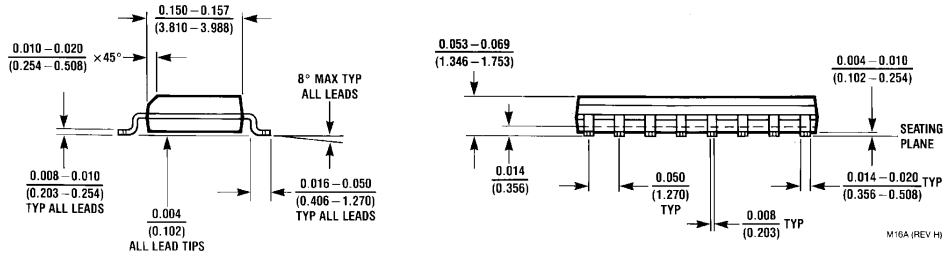
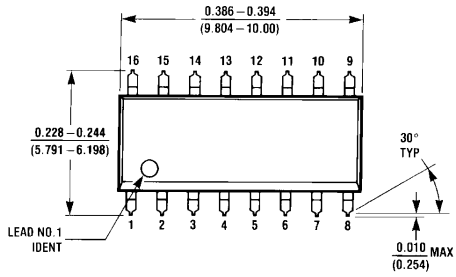

**16-Lead Small Outline Integrated Circuit (SOIC), JEDEC MS-012, 0.150" Narrow
Package Number M16A**

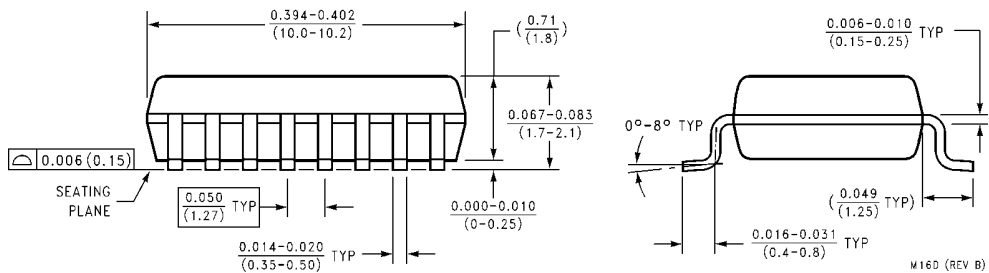
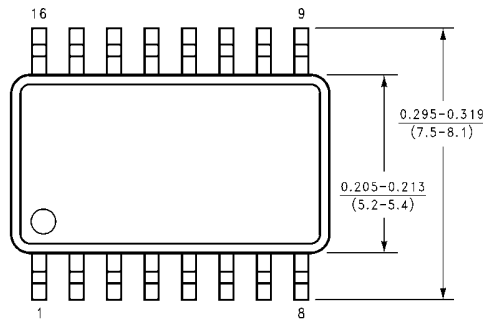

**16-Lead Small Outline Package (SOP), EIAJ TYPE II, 5.3mm Wide
Package Number M16D**

Physical Dimensions inches (millimeters) unless otherwise noted (Continued)

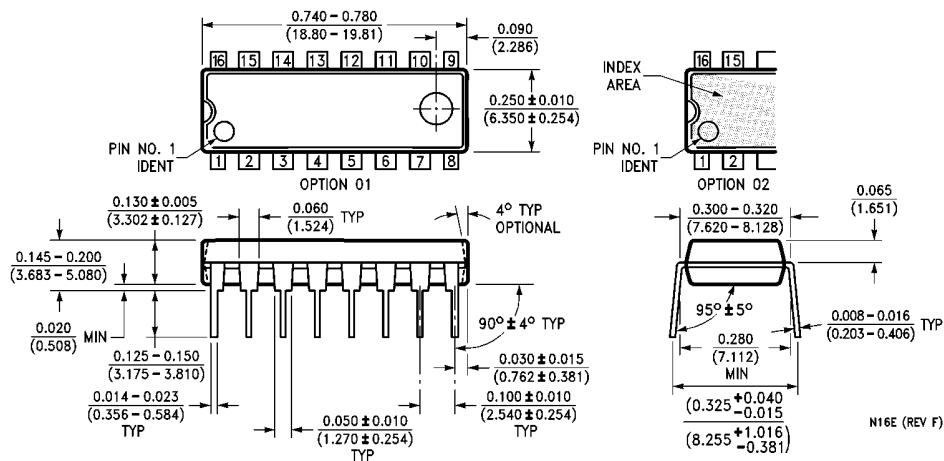

16-Lead Plastic Dual-In-Line Package (PDIP), JEDEC MS-1, 0.300" Wide Package Number N16E

N16E (REV F)

LIFE SUPPORT POLICY

FAIRCHILD'S PRODUCTS ARE NOT AUTHORIZED FOR USE AS CRITICAL COMPONENTS IN LIFE SUPPORT DEVICES OR SYSTEMS WITHOUT THE EXPRESS WRITTEN APPROVAL OF THE PRESIDENT OF FAIRCHILD SEMICONDUCTOR CORPORATION. As used herein:

1. Life support devices or systems are devices or systems which, (a) are intended for surgical implant into the body, or (b) support or sustain life, and (c) whose failure to perform when properly used in accordance with instructions for use provided in the labeling, can be reasonably expected to result in a significant injury to the user.
2. A critical component in any component of a life support device or system whose failure to perform can be reasonably expected to cause the failure of the life support device or system, or to affect its safety or effectiveness.

www.fairchildsemi.com

Fairchild does not assume any responsibility for use of any circuitry described, no circuit patent licenses are implied and Fairchild reserves the right at any time without notice to change said circuitry and specifications.