

## CD4528BC Dual Monostable Multivibrator

### General Description

The CD4528B is a dual monostable multivibrator. Each device is retriggerable and resettable. Triggering can occur from either the rising or falling edge of an input pulse, resulting in an output pulse over a wide range of widths. Pulse duration and accuracy are determined by external timing components Rx and Cx.

### Features

- Wide supply voltage range: 3.0V to 18V
- Separate reset available
- Quiescent current = 5.0 nA/package (typ.) at 5.0 V<sub>DC</sub>
- Diode protection on all inputs
- Triggerable from leading or trailing edge pulse
- Capable of driving two low-power TTL loads or one low-power Schottky TTL load over the rated temperature range

### Ordering Code:

| Order Number | Package Number | Package Description   |
|--------------|----------------|---|
| CD4528BCM    | M16A           | 16-Lead Small Outline Integrated Circuit (SOIC), JEDEC MS-012, 0.150 Narrow |
| CD4528BCN    | N16E           | 16-Lead Plastic Dual-In-Line Package (PDIP), JEDEC MS-001, 0.300 Wide       |

Devices also available in Tape and Reel. Specify by appending the suffix letter "X" to the ordering code.

### Connection Diagram

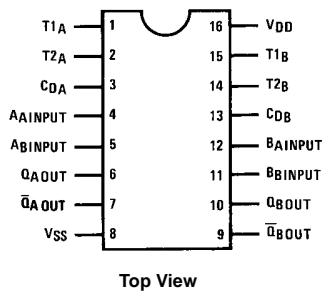

### Truth Table

| Clear | Inputs |   | Outputs |   |
|-------|--------|---|---------|---|
|       | A      | B | Q       | Q |
| L     | X      | X | L       | H |
| X     | H      | X | L       | H |
| X     | X      | L | L       | H |
| H     | L      | ↓ | ⌊       | ⌋ |
| H     | ↑      | H | ⌊       | ⌋ |

H = HIGH Level  
L = LOW Level  
↑ = Transition from LOW-to-HIGH  
↓ = Transition from HIGH-to-LOW  
⌊ = One HIGH Level Pulse  
⌋ = One LOW Level Pulse  
X = Irrelevant

**Block Diagram**

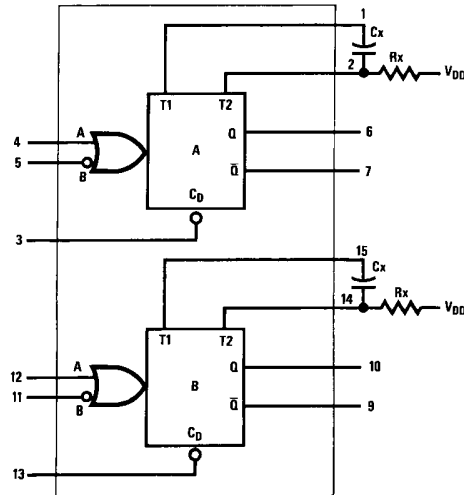

**Logic Diagram**

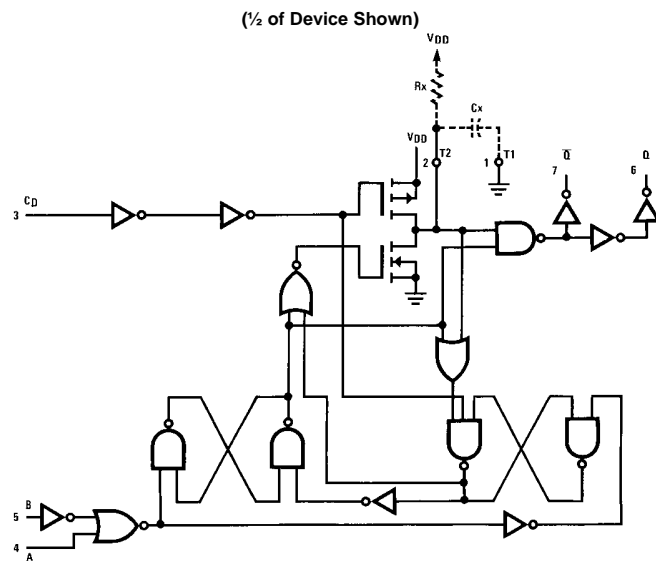

**Note:** Externally ground pins 1 and 15 to pin 8.

| Absolute Maximum Ratings (Note 1)                                     |   |  | Recommended Operating Conditions (Note 2)  |  |                       |            |                       |       |       |               |
|---|---|--|--|--|-----------------------|------------|-----------------------|-------|-------|---------------|
| (Note 2)  |   |  |  |  |                       |            |                       |       |       |               |
| DC Supply Voltage ( $V_{DD}$ )  | $-0.5 V_{DC}$ to $+18 V_{DC}$                   |  | DC Supply Voltage ( $V_{DD}$ )   | 3V to 15V                                      |                       |            |                       |       |       |               |
| Input Voltage, All Inputs ( $V_{IN}$ )                                | $-0.5 V_{DC}$ to $V_{DD} + 0.5 V_{DC}$          |  | Input Voltage ( $V_{IN}$ )   | 0V to $V_{DD}$ $V_{DC}$                        |                       |            |                       |       |       |               |
| Storage Temperature Range ( $T_S$ )                                   | $-65^{\circ}\text{C}$ to $+150^{\circ}\text{C}$ |  | Operating Temperature Range ( $T_A$ )  | $-40^{\circ}\text{C}$ to $+85^{\circ}\text{C}$ |                       |            |                       |       |       |               |
| Power Dissipation ( $P_D$ )   |   |  | <b>Note 1:</b> "Absolute Maximum Ratings" are those values beyond which the safety of the device cannot be guaranteed. Except for "Operating Temperature Range", they are not meant to imply that the devices should be operated at these limits. The table of "Electrical Characteristics" provides conditions for actual device operation. |  |                       |            |                       |       |       |               |
| Dual-In-Line  | 700 mW  |  | <b>Note 2:</b> $V_{SS} = 0\text{V}$ unless otherwise specified.  |  |                       |            |                       |       |       |               |
| Small Outline   | 500 mW  |  |  |  |                       |            |                       |       |       |               |
| Lead Temperature ( $T_L$ )  |   |  |  |  |                       |            |                       |       |       |               |
| (Soldering, 10 seconds)   | 260 $^{\circ}\text{C}$                          |  |  |  |                       |            |                       |       |       |               |
| DC Electrical Characteristics (Note 3)                                |   |  |  |  |                       |            |                       |       |       |               |
| Symbol  | Parameter                                       | Conditions   | $-40^{\circ}\text{C}$  |  | $+25^{\circ}\text{C}$ |            | $+85^{\circ}\text{C}$ |       | Units |               |
|   |   |  | Min  | Max  | Min                   | Typ        | Max                   | Min   |       | Max           |
| $I_{DD}$  | Quiescent Device Current                        | $V_{DD} = 5\text{V}$                                       |  | 20   |                       | 0.005      | 20                    |       | 150   | $\mu\text{A}$ |
|   |   | $V_{DD} = 10\text{V}$                                      |  | 40   |                       | 0.010      | 40                    |       | 300   | $\mu\text{A}$ |
|   |   | $V_{DD} = 15\text{V}$                                      |  | 80   |                       | 0.015      | 80                    |       | 600   | $\mu\text{A}$ |
| $V_{OL}$  | LOW Level Output Voltage                        | $V_{DD} = 5\text{V}$                                       |  | 0.05   |                       |            | 0.05                  |       | 0.05  | V             |
|   |   | $V_{DD} = 10\text{V}$                                      |  | 0.05   |                       |            | 0.05                  |       | 0.05  | V             |
|   |   | $V_{DD} = 15\text{V}$                                      |  | 0.05   |                       |            | 0.05                  |       | 0.05  | V             |
| $V_{OH}$  | HIGH Level Output Voltage                       | $V_{DD} = 5\text{V}$                                       | 4.95   |  | 4.95                  | 5.0        |                       | 4.95  |       | V             |
|   |   | $V_{DD} = 10\text{V}$                                      | 9.95   |  | 9.95                  | 10.0       |                       | 9.95  |       | V             |
|   |   | $V_{DD} = 15\text{V}$                                      | 14.95  |  | 14.95                 | 15.0       |                       | 14.95 |       | V             |
| $V_{IL}$  | LOW Level Input Voltage                         | $V_{DD} = 5\text{V}, V_O = 0.5\text{V}$ or $4.5\text{V}$   |  | 1.5  |                       | 2.25       | 1.5                   |       | 1.5   | V             |
|   |   | $V_{DD} = 10\text{V}, V_O = 1\text{V}$ or $9\text{V}$      |  | 3.0  |                       | 4.50       | 3.0                   |       | 3.0   | V             |
|   |   | $V_{DD} = 15\text{V}, V_O = 1.5\text{V}$ or $13.5\text{V}$ |  | 4.0  |                       | 6.75       | 4.0                   |       | 4.0   | V             |
| $V_{IH}$  | HIGH Level Input Voltage                        | $V_{DD} = 5\text{V}, V_O = 0.5\text{V}$ or $4.5\text{V}$   | 3.5  |  | 3.5                   | 2.75       |                       | 3.5   |       | V             |
|   |   | $V_{DD} = 10\text{V}, V_O = 1\text{V}$ or $9\text{V}$      | 7.0  |  | 7.0                   | 5.50       |                       | 7.0   |       | V             |
|   |   | $V_{DD} = 15\text{V}, V_O = 1.5\text{V}$ or $13.5\text{V}$ | 11.0   |  | 11.0                  | 8.25       |                       | 11.0  |       | V             |
| $I_{OL}$  | LOW Level Output Current (Note 4)               | $V_{DD} = 5\text{V}, V_O = 0.4\text{V}$                    | 0.52   |  | 0.44                  | 0.88       |                       | 0.36  |       | mA            |
|   |   | $V_{DD} = 10\text{V}, V_O = 0.5\text{V}$                   | 1.3  |  | 1.1                   | 2.25       |                       | 0.9   |       | mA            |
|   |   | $V_{DD} = 15\text{V}, V_O = 1.5\text{V}$                   | 3.6  |  | 3.0                   | 8.8        |                       | 2.4   |       | mA            |
| $I_{OH}$  | HIGH Level Output Current (Note 4)              | $V_{DD} = 5\text{V}, V_O = 4.6\text{V}$                    | -0.2   |  | -0.16                 | -0.36      |                       | -0.12 |       | mA            |
|   |   | $V_{DD} = 10\text{V}, V_O = 9.5\text{V}$                   | -0.5   |  | -0.4                  | -0.9       |                       | -0.3  |       | mA            |
|   |   | $V_{DD} = 15\text{V}, V_O = 13.5\text{V}$                  | -1.4   |  | -1.2                  | -3.5       |                       | -1.0  |       | mA            |
| $I_{IN}$  | Input Current                                   | $V_{DD} = 15\text{V}, V_{IN} = 0\text{V}$                  |  | -0.3   |                       | $-10^{-5}$ | -0.3                  |       | -1.0  | $\mu\text{A}$ |
|   |   | $V_{DD} = 15\text{V}, V_{IN} = 15\text{V}$                 |  | 0.3  |                       | $10^{-5}$  | 0.3                   |       | 1.0   | $\mu\text{A}$ |
| <b>Note 3:</b> $V_{SS} = 0\text{V}$ unless otherwise specified.       |   |  |  |  |                       |            |                       |       |       |               |
| <b>Note 4:</b> $I_{OH}$ and $I_{OL}$ are tested one output at a time. |   |  |  |  |                       |            |                       |       |       |               |

| <b>AC Electrical Characteristics</b> (Note 5)  |   |  |                        |     |     |               |               |
|--|---|--|------------------------|-----|-----|---------------|---------------|
| $T_A = 25^\circ\text{C}$ , $C_L = 50\text{ pF}$ , $R_L = 200\text{ k}\Omega$ , Input $t_r = t_f = 20\text{ ns}$ , unless otherwise specified |   |  |                        |     |     |               |               |
| Symbol   | Parameter   | Conditions   | Min                    | Typ | Max | Units         |               |
| $t_r$  | Output Rise Time  | $t_r = (3.0\text{ ns/pF}) C_L + 30\text{ ns}$ , $V_{DD} = 5.0\text{V}$   |                        | 180 | 400 | ns            |               |
|  |   | $t_r = (1.5\text{ ns/pF}) C_L + 15\text{ ns}$ , $V_{DD} = 10.0\text{V}$  |                        | 90  | 200 | ns            |               |
|  |   | $t_r = (1.1\text{ ns/pF}) C_L + 10\text{ ns}$ , $V_{DD} = 15.0\text{V}$  |                        | 65  | 160 | ns            |               |
| $t_f$  | Output Fall Time  | $t_f = (1.5\text{ ns/pF}) C_L + 25\text{ ns}$ , $V_{DD} = 5.0\text{V}$   |                        | 100 | 200 | ns            |               |
|  |   | $t_f = (0.75\text{ ns/pF}) C_L + 12.5\text{ ns}$ , $V_{DD} = 10\text{V}$   |                        | 50  | 100 | ns            |               |
|  |   | $t_f = (0.55\text{ ns/pF}) C_L + 9.5\text{ ns}$ , $V_{DD} = 15.0\text{V}$  |                        | 35  | 80  | ns            |               |
| $t_{PLH}$<br>$t_{PHL}$   | Turn-Off, Turn-On Delay<br>A or B to Q or $\bar{Q}$<br>Cx = 15 pF, Rx = 5.0 k $\Omega$  | $t_{PLH}, t_{PHL} = (1.7\text{ ns/pF}) C_L + 240\text{ ns}$ , $V_{DD} = 5.0\text{V}$   |                        | 230 | 500 | ns            |               |
|  |   | $t_{PLH}, t_{PHL} = (0.66\text{ ns/pF}) C_L + 8\text{ ns}$ , $V_{DD} = 10.0\text{V}$   |                        | 100 | 250 | ns            |               |
|  |   | $t_{PLH}, t_{PHL} = (0.5\text{ ns/pF}) C_L + 65\text{ ns}$ , $V_{DD} = 15.0\text{V}$   |                        | 65  | 150 | ns            |               |
| $t_{PLH}$<br>$t_{PHL}$   | Turn-Off, Turn-On Delay<br>A or B to Q or $\bar{Q}$<br>Cx = 100 pF, Rx = 10 k $\Omega$  | $t_{PLH}, t_{PHL} = (1.7\text{ ns/pF}) C_L + 620\text{ ns}$ , $V_{DD} = 5.0\text{V}$   |                        | 230 | 500 | ns            |               |
|  |   | $t_{PLH}, t_{PHL} = (0.66\text{ ns/pF}) C_L + 257\text{ ns}$ , $V_{DD} = 10.0\text{V}$                                       |                        | 100 | 250 | ns            |               |
|  |   | $t_{PLH}, t_{PHL} = (0.5\text{ ns/pF}) C_L + 185\text{ ns}$ , $V_{DD} = 15.0\text{V}$  |                        | 65  | 150 | ns            |               |
| $t_{WL}$<br>$t_{WH}$   | Minimum Input Pulse Width<br>A or B<br>Cx = 15 pF, Rx = 5.0 k $\Omega$  | $V_{DD} = 5.0\text{V}$   |                        | 60  | 150 | ns            |               |
|  |   | $V_{DD} = 10.0\text{V}$  |                        | 20  | 50  | ns            |               |
|  |   | $V_{DD} = 15\text{V}$  |                        | 20  | 50  | ns            |               |
| $t_{WL}$<br>$t_{WH}$   | Cx = 1000 pF, Rx = 10 k $\Omega$  | $V_{DD} = 5.0\text{V}$   |                        | 60  | 150 | ns            |               |
|  |   | $V_{DD} = 10.0\text{V}$  |                        | 20  | 50  | ns            |               |
|  |   | $V_{DD} = 15.0\text{V}$  |                        | 20  | 50  | ns            |               |
| $PW_{OUT}$   | Output Pulse Width Q or $\bar{Q}$<br>For Cx < 0.01 $\mu\text{F}$ (See Graph<br>for Appropriate $V_{DD}$ Level)<br>Cx = 15 pF, Rx = 5.0 k $\Omega$ | $V_{DD} = 5.0\text{V}$   |                        | 550 |     | ns            |               |
|  |   | $V_{DD} = 10.0\text{V}$  |                        | 350 |     | ns            |               |
|  |   | $V_{DD} = 15.0\text{V}$  |                        | 300 |     | ns            |               |
|  |   | For Cx > 0.01 $\mu\text{F}$ Use<br>$PW_{out} = 0.2\text{ Rx Cx ln } [V_{DD} - V_{SS}]$<br>Cx = 10,000 pF, Rx = 10 k $\Omega$ | $V_{DD} = 5.0\text{V}$ | 15  | 29  | 45            | $\mu\text{s}$ |
|  |   | $V_{DD} = 10.0\text{V}$  | 10                     | 37  | 90  | $\mu\text{s}$ |               |
|  |   | $V_{DD} = 15.0\text{V}$  | 15                     | 42  | 95  | $\mu\text{s}$ |               |
| $t_{PLH}$<br>$t_{PHL}$   | Reset Propagation Delay,<br>$t_{PLH}, t_{PHL}$<br>Cx = 15 pF, Rx = 5.0 k $\Omega$   | $V_{DD} = 5.0\text{V}$   |                        | 325 | 600 | ns            |               |
|  |   | $V_{DD} = 10.0\text{V}$  |                        | 90  | 225 | ns            |               |
|  |   | $V_{DD} = 15.0\text{V}$  |                        | 60  | 170 | ns            |               |
| $t_{PLH}$<br>$t_{PHL}$   | Cx = 1000 pF, Rx = 10 k $\Omega$  | $V_{DD} = 5.0\text{V}$   |                        | 7.0 |     | $\mu\text{s}$ |               |
|  |   | $V_{DD} = 10.0\text{V}$  |                        | 6.7 |     | $\mu\text{s}$ |               |
|  |   | $V_{DD} = 15.0\text{V}$  |                        | 6.7 |     | $\mu\text{s}$ |               |
| $t_{RR}$   | Minimum Retrigger Time<br>Cx = 15 pF, Rx = 5.0 k $\Omega$   | $V_{DD} = 5.0\text{V}$   |                        | 0   |     | ns            |               |
|  |   | $V_{DD} = 10.0\text{V}$  |                        | 0   |     | ns            |               |
|  |   | $V_{DD} = 15.0\text{V}$  |                        | 0   |     | ns            |               |
|  |   | Cx = 1000 pF, Rx = 10 k $\Omega$   | $V_{DD} = 5.0\text{V}$ |     | 0   |               | ns            |
|  |   | $V_{DD} = 10.0\text{V}$  |                        | 0   |     | ns            |               |
|  |   | $V_{DD} = 15.0\text{V}$  |                        | 0   |     | ns            |               |
| Pulse Width Match between Circuits<br>in the Same Package<br>Cx = 10,000 pF, Rx = 10 k $\Omega$  | $V_{DD} = 5.0\text{V}$  |  |                        | 6   | 25  | %             |               |
|  | $V_{DD} = 10.0\text{V}$   |  |                        | 8   | 35  | %             |               |
|  | $V_{DD} = 15.0\text{V}$   |  |                        | 8   | 35  | %             |               |

**Note 5:** AC parameters are guaranteed by DC correlated testing.

Pulse Widths

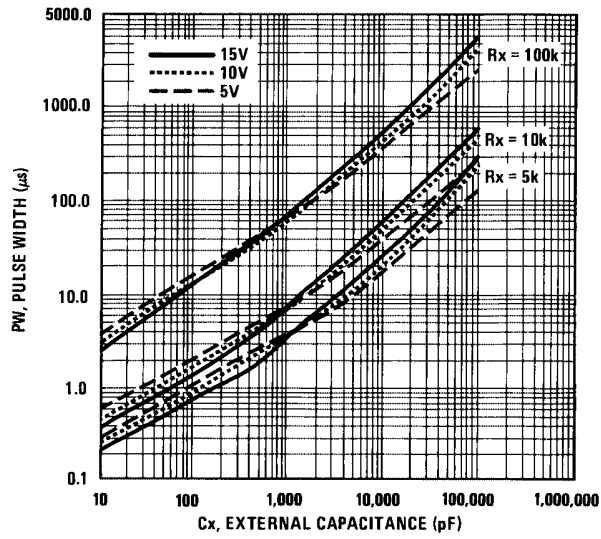

FIGURE 1. Pulse Width vs Cx

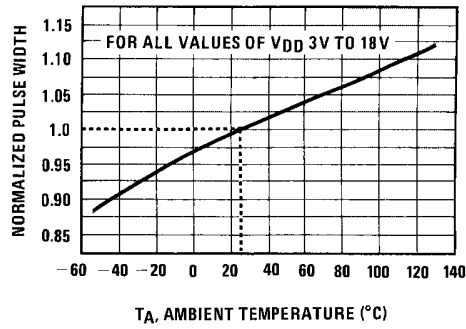
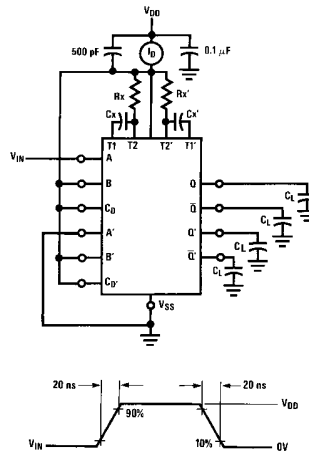

FIGURE 2. Normalized Pulse Width vs Temperature

AC Test Circuits and Waveforms



Duty Cycle = 50%

FIGURE 3. Power Dissipation Test Circuit and Waveforms

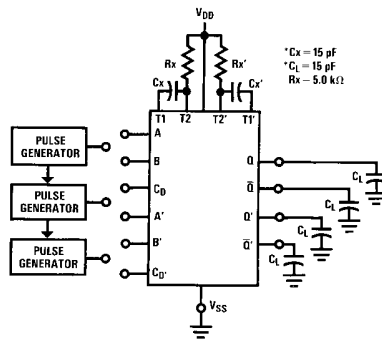

\*Includes capacitance of probes, wiring, and fixture parasitic.  
**Note:** AC test waveforms for PG1, PG2, and PG3 in Figure 4.

Input Connections

| Characteristics   | C <sub>D</sub>  | A               | B               |
|---|-----------------|-----------------|-----------------|
| t <sub>PLH</sub> , t <sub>PHL</sub> , t <sub>r</sub> , t <sub>f</sub> ,<br>PW <sub>out</sub> , PW <sub>in</sub> | V <sub>DD</sub> | PG1             | V <sub>DD</sub> |
| t <sub>PLH</sub> , t <sub>PHL</sub> , t <sub>r</sub> , t <sub>f</sub> ,<br>PW <sub>out</sub> , PW <sub>in</sub> | V <sub>DD</sub> | V <sub>SS</sub> | PG2             |
| t <sub>PLH(R)</sub> , t <sub>PHL(R)</sub> , PW <sub>in</sub>  | PG3             | PG1             | PG2             |

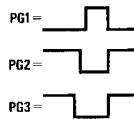

FIGURE 4. AC Test Circuit

AC Test Circuits and Waveforms (Continued)

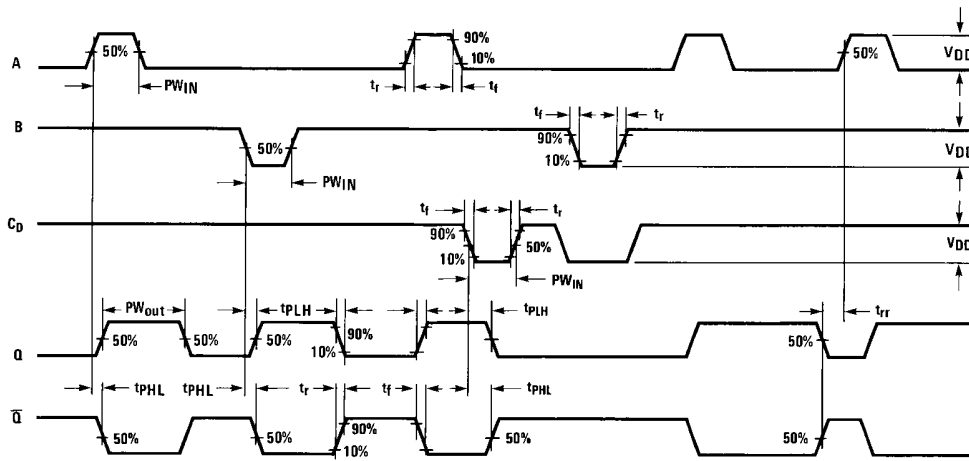
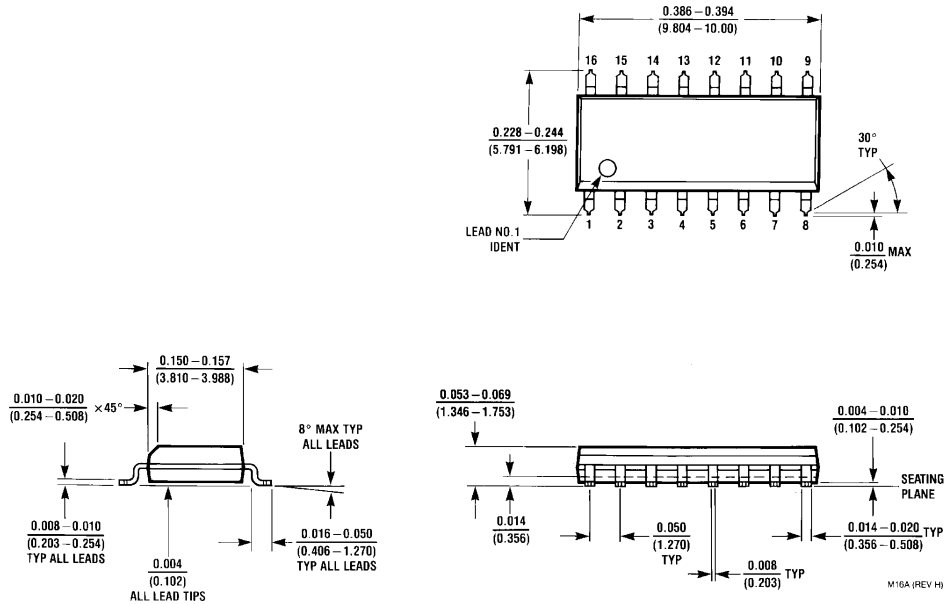

FIGURE 5. AC Test Waveforms

**Physical Dimensions** inches (millimeters) unless otherwise noted



**16-Lead Small Outline Integrated Circuit (SOIC), JEDEC MS-012, 0.150 Narrow  
Package Number M16A**



**Physical Dimensions** inches (millimeters) unless otherwise noted (Continued)

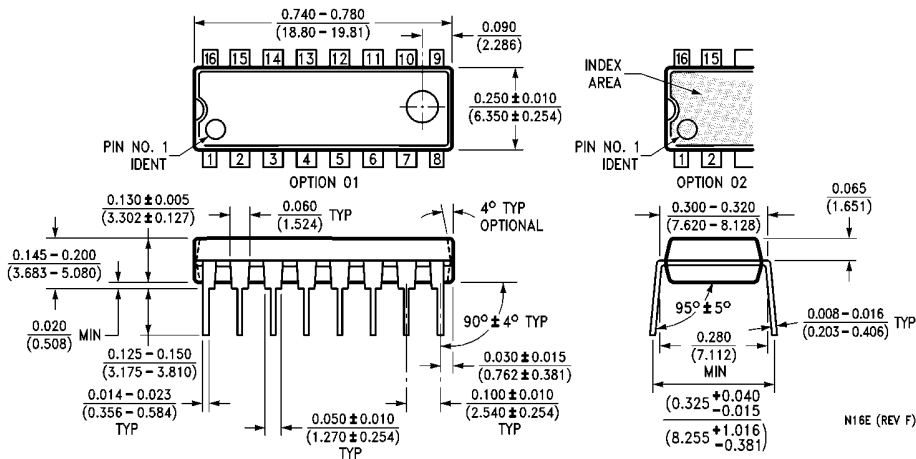

**16-Lead Plastic Dual-In-Line Package (PDIP), JEDEC MS-001, 0.300 Wide Package Number N16E**

Fairchild does not assume any responsibility for use of any circuitry described, no circuit patent licenses are implied and Fairchild reserves the right at any time without notice to change said circuitry and specifications.

**LIFE SUPPORT POLICY**

FAIRCHILD'S PRODUCTS ARE NOT AUTHORIZED FOR USE AS CRITICAL COMPONENTS IN LIFE SUPPORT DEVICES OR SYSTEMS WITHOUT THE EXPRESS WRITTEN APPROVAL OF THE PRESIDENT OF FAIRCHILD SEMICONDUCTOR CORPORATION. As used herein:

1. Life support devices or systems are devices or systems which, (a) are intended for surgical implant into the body, or (b) support or sustain life, and (c) whose failure to perform when properly used in accordance with instructions for use provided in the labeling, can be reasonably expected to result in a significant injury to the user.
2. A critical component in any component of a life support device or system whose failure to perform can be reasonably expected to cause the failure of the life support device or system, or to affect its safety or effectiveness.

[www.fairchildsemi.com](http://www.fairchildsemi.com)