

## DM74ALS253 3-STATE Dual 1-of-4 Line Data Selector/Multiplexer

### General Description

This Data Selector/Multiplexer contains full on-chip decoding to select one-of-four data sources as a result of a unique two-bit binary code at the Select Inputs. Each of the two Data Selector/Multiplexer circuits have their own separate Data and Output Control inputs and a non-inverting 3-STATE output buffer. The Output Control inputs, when at the high level, place the corresponding output in the high impedance OFF-State. In order to prevent bus access conflicts, output disable times are shorter than output enable times. The Select input buffers incorporate internal overlap features to ensure that select input changes do not cause invalid output transients.

### Features

- Advanced oxide-isolated, ion-implanted Schottky TTL process
- Switching performance is guaranteed over full temperature and V<sub>CC</sub> supply range
- Pin and functional compatible with LS family counterpart
- Improved output transient handling capability
- Output control circuitry incorporates power-up 3-STATE feature

### Ordering Code:

Order Number	Package Number	Package Description
DM74ALS253M	M16A	16-Lead Small Outline Integrated Circuit (SOIC), JEDEC MS-012, 0.150 Narrow
DM74ALS253N	N16E	16-Lead Plastic Dual-In-Line Package (PDIP), JEDEC MS-001, 0.300 Wide

Devices also available in Tape and Reel. Specify by appending the suffix letter "X" to the ordering code.

### Connection Diagram

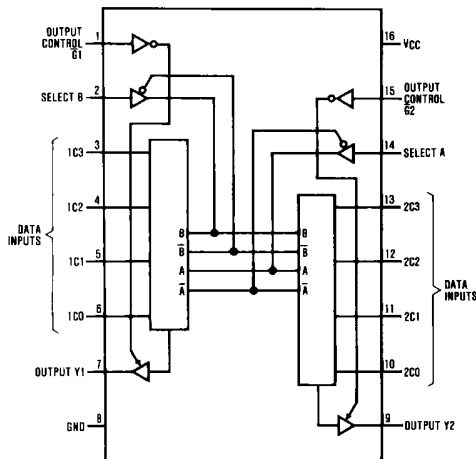

### Function Table

Select Inputs		Data Inputs				Output Control	Output
B	A	C0	C1	C2	C3	$\bar{G}$	Y
X	X	X	X	X	X	H	Z
L	L	L	X	X	X	L	L
L	L	H	X	X	X	L	H
L	H	X	L	X	X	L	L
L	H	X	H	X	X	L	H
H	L	X	X	L	X	L	L
H	L	X	X	H	X	L	H
H	H	X	X	X	L	L	L
H	H	X	X	X	H	L	H

Address inputs A and B are common to both sections

H = HIGH Level  
L = LOW Level  
X = Don't Care  
Z = High Impedance

### Logic Diagram

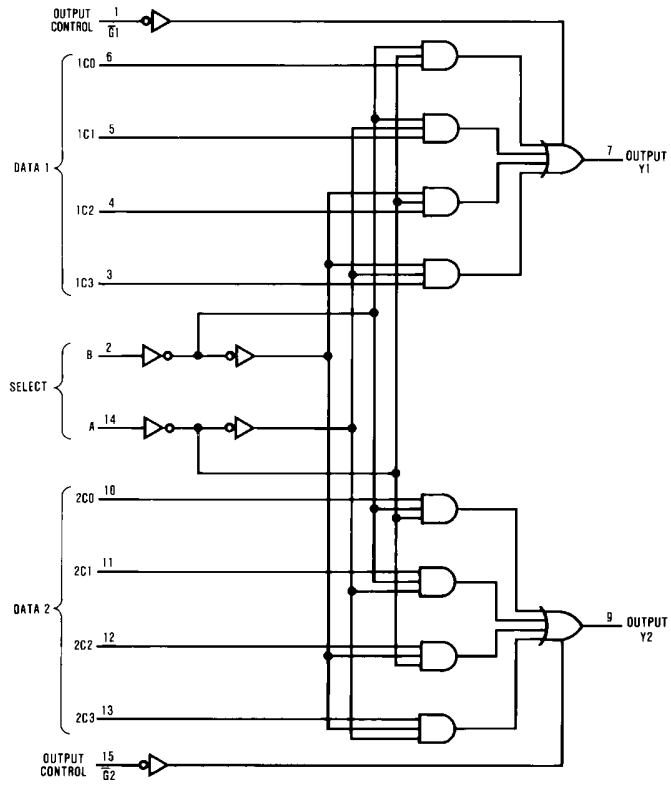

**Absolute Maximum Ratings**(Note 1)

Supply Voltage, $V_{CC}$	7V
Input Voltage	7V
Voltage Applied to Disabled Output	5.5V
Operating Free Air Temperature Range	0°C to +70°C
Storage Temperature Range	-65°C to +150°C
Typical $\theta_{JA}$	
N Package	78.0°C/W
M Package	107.0°C/W

**Note 1:** The "Absolute Maximum Ratings" are those values beyond which the safety of the device cannot be guaranteed. The device should not be operated at these limits. The parametric values defined in the Electrical Characteristics tables are not guaranteed at the absolute maximum ratings. The "Recommended Operating Conditions" table will define the conditions for actual device operation.

**Recommended Operating Conditions**

Symbol	Parameter	Min	Nom	Max	Units
$V_{CC}$	Supply Voltage	4.5	5	5.5	V
$V_{IH}$	HIGH Level Input Voltage	2			V
$V_{IL}$	LOW Level Input Voltage			0.8	V
$I_{OH}$	HIGH Level Output Current			-2.6	mA
$I_{OL}$	LOW Level Output Current			24	mA
$T_A$	Free Air Operating Temperature	0		70	°C

**Electrical Characteristics**

over recommended operating free air temperature range. All typical values are measured at  $V_{CC} = 5V$ ,  $T_A = 25^\circ C$ .

Symbol	Parameter	Conditions	Min	Typ	Max	Units	
$V_{IK}$	Input Clamp Voltage	$V_{CC} = 4.5V$ , $I_{IN} = -18 mA$			-1.5	V	
$V_{OH}$	HIGH Level Output Voltage	$V_{CC} = 4.5V$ , $I_{OH} = \text{Max}$	2.4	3.2		V	
		$I_{OH} = 400 \mu A$ , $V_{CC} = 4.5V$ to $5.5V$	$V_{CC} - 2$				
$V_{OL}$	LOW Level Output Voltage	$V_{CC} = 4.5V$		0.25	0.4	V	
				$I_{OL} = 12 mA$			
				0.35	0.5		
$I_I$	Input Current at Maximum input Voltage	$V_{CC} = 5.5V$ , $V_{IN} = 7V$			0.1	mA	
$I_{IH}$	HIGH Level Input Current	$V_{CC} = 5.5V$ , $V_{IN} = 2.7V$			20	$\mu A$	
$I_{IL}$	LOW Level Input Current	$V_{CC} = 5.5V$ , $V_{IN} = 0.4V$			-0.1	mA	
$I_O$	Output Drive Current	$V_{CC} = 5.5V$ , $V_{OUT} = 2.25V$	-30		-112	mA	
$I_{OZH}$	OFF-State Output Current, HIGH Bias	$V_{CC} = 5.5V$ , $V_{OUT} = 2.7V$			20	$\mu A$	
$I_{OZL}$	OFF-State Output Current, LOW Bias	$V_{CC} = 5.5V$ , $V_{OUT} = 0.4V$			-20	$\mu A$	
$I_{CC}$	Supply Current	$V_{CC} = 5.5V$	Output HIGH	6.5	12	mA	
			Output LOW		6.5		12
			Output Disabled		7.5		14

**Switching Characteristics**

over recommended operating free air temperature range. All typical values are measured at  $V_{CC} = 5V$ ,  $T_A = 25^\circ C$ .

Symbol	Parameter	Conditions	From (Input) To (Output)	Min	Max	Units
$t_{PLH}$	Propagation Delay Time LOW-to-HIGH Level Output	$V_{CC} = 4.5V$ to $5.5V$ $C_L = 50 pF$ $R_L = 500\Omega$	Select to Y	5	21	ns
$t_{PHL}$	Propagation Delay Time HIGH-to-LOW Level Output		Select to Y	5	21	ns
$t_{PLH}$	Propagation Delay Time LOW-to-HIGH Level Output		Data to Y	2	10	ns
$t_{PHL}$	Propagation Delay Time HIGH-to-LOW Level Output		Data to Y	3	14	ns
$t_{PZH}$	Output Enable Time to HIGH Level Output		Output Control to Y	3	14	ns
$t_{PZL}$	Output Enable Time to LOW Level Output		Output Control to Y	4	16	ns
$t_{PHZ}$	Output Disable Time from HIGH Level Output		Output Control to Y	2	10	ns
$t_{PLZ}$	Output Disable Time from LOW Level Output		Output Control to Y	2	14	ns

**Physical Dimensions** inches (millimeters) unless otherwise noted

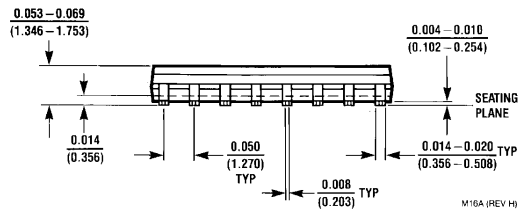
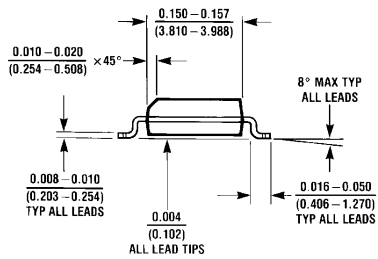
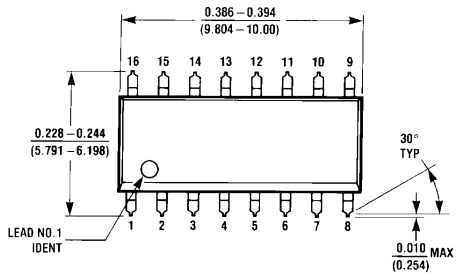

**16-Lead Small Outline Integrated Circuit (SOIC), JEDEC MS-012, 0.150 Narrow  
Package Number M16A**

