

## DM74ALS257 • DM74ALS258

### 3-STATE Quad 1-of-2-Line Data Selector/Multiplexer

#### General Description

These data selectors/multiplexers contain inverters and drivers to supply full on-chip data selection to the four 3-STATE outputs that can interface directly with data lines of bus-organized systems. A 4-bit word selected from one of two sources is routed to the four outputs. The DM74ALS257 presents true data whereas the DM74ALS258 presents inverted data to minimize propagation delay time.

This 3-STATE output feature means that n-bit (paralleled) data selectors with up to 258 sources can be implemented for data buses. It also permits the use of standard TTL registers for data retention throughout the system.

#### Features

- Switching specifications at 50 pF
- Switching specifications guaranteed over full temperature and  $V_{CC}$  range
- Advanced oxide-isolated, ion-implanted Schottky TTL process
- Functionally and pin for pin compatible with Schottky and low power Schottky TTL counterpart
- Improved AC performance over Schottky and low power Schottky counterparts
- 3-STATE buffer-type outputs drive bus lines directly
- Expand any data input point
- Multiplex dual data buses
- General four functions of two variables (one variable is common)
- Source programmable counters

#### Ordering Code:

Order Number	Package Number	Package Description
DM74ALS257M	M16A	16-Lead Small Outline Integrated Circuit (SOIC), JEDEC MS-012, 0.150 Narrow
DM74ALS257SJ	M16D	16-Lead Small Outline Package (SOP), EIAJ TYPE II, 5.3mm Wide
DM74ALS257N	N16E	16-Lead Plastic Dual-In-Line Package (PDIP), JEDEC MS-001, 0.300 Wide
DM74ALS258M	M16A	16-Lead Small Outline Integrated Circuit (SOIC), JEDEC MS-012, 0.150 Narrow
DM74ALS258N	N16E	16-Lead Plastic Dual-In-Line Package (PDIP), JEDEC MS-001, 0.300 Wide

Devices also available in Tape and Reel. Specify by appending the suffix letter "X" to the ordering code.

#### Connection Diagram

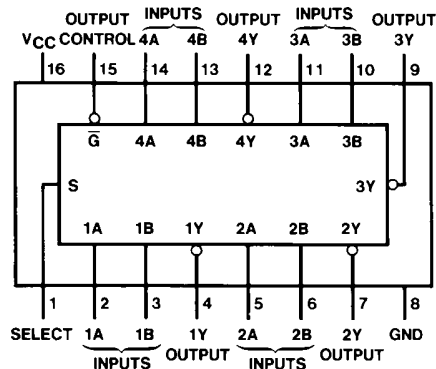

#### Function Table

Output Control	Inputs			Output Y	
	Select	A	B	DM74ALS257	DM74ALS258
H	X	X	X	Z	Z
L	L	L	X	L	H
L	L	H	X	H	L
L	H	X	L	L	H
L	H	X	H	H	L

H = HIGH Level  
L = LOW Level  
X = Don't Care  
Z = High Impedance (OFF)

Logic Diagrams

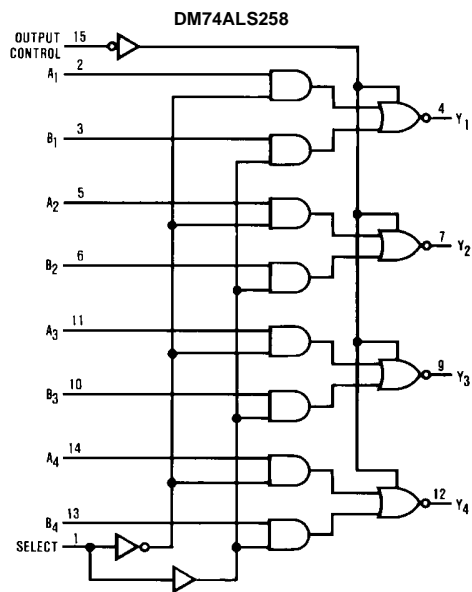
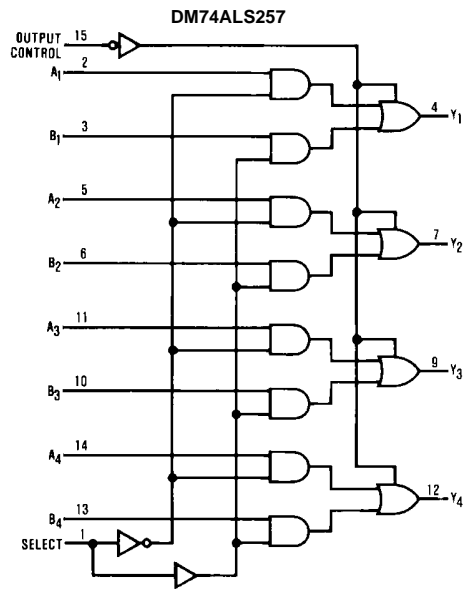

**Absolute Maximum Ratings**(Note 1)

Supply Voltage	7V
Input Voltage	7V
Voltage Applied to Disabled Output	5.5V
Operating Free Air Temperature Range	0°C to +70°C
Storage Temperature Range	-65°C to +150°C
Typical $\theta_{JA}$	
N Package	73.0°C/W
M Package	102.0°C/W

**Note 1:** The "Absolute Maximum Ratings" are those values beyond which the safety of the device cannot be guaranteed. The device should not be operated at these limits. The parametric values defined in the Electrical Characteristics tables are not guaranteed at the absolute maximum ratings. The "Recommended Operating Conditions" table will define the conditions for actual device operation.

**Recommended Operating Conditions**

Symbol	Parameter	Min	Nom	Max	Units
$V_{CC}$	Supply Voltage	4.5	5	5.5	V
$V_{IH}$	HIGH Level Input Voltage	2			V
$V_{IL}$	LOW Level Input Voltage			0.8	V
$I_{OH}$	HIGH Level Output Current			-2.6	mA
$I_{OL}$	LOW Level Output Current			24	mA
$T_A$	Free Air Operating Temperature	0		70	°C

**Electrical Characteristics**

over recommended operating free air temperature range. All typical values are measured at  $V_{CC} = 5V$ ,  $T_A = 25^\circ C$ .

Symbol	Parameter	Conditions	Min	Typ	Max	Units	
$V_{IK}$	Input Clamp Voltage	$V_{CC} = 4.5V$ , $I_I = -18\text{ mA}$			-1.5	V	
$V_{OH}$	HIGH Level Output Voltage	$V_{CC} = 4.5V$ $I_{OH} = -0.4\text{ mA}$	$I_{OH} = -2.6\text{ mA}$	2.4	3.3	V	
				$V_{CC} - 2$		V	
$V_{OL}$	LOW Level Output Voltage	$V_{CC} = 4.5V$	$I_{OL} = 12\text{ mA}$		0.25	0.4	V
			$I_{OL} = 24\text{ mA}$		0.35	0.5	V
$I_I$	Input Current at Maximum Input Voltage	$V_{CC} = 5.5V$ , $V_{IH} = 7V$			0.1	mA	
$I_{IH}$	HIGH Level Input Current	$V_{CC} = 5.5V$ , $V_{IH} = 2.7V$			20	$\mu A$	
$I_{IL}$	LOW Level Input Current	$V_{CC} = 5.5V$ , $V_{IL} = 0.4V$			-0.1	mA	
$I_O$	Output Drive Current	$V_{CC} = 5.5V$ , $V_O = 2.25V$	-30		-112	mA	
$I_{OZH}$	OFF-State Output Current HIGH Level Voltage Applied	$V_{CC} = 5.5V$ , $V_O = 2.7V$			20	$\mu A$	
$I_{OZL}$	OFF-State Output Current, LOW Level Voltage Applied	$V_{CC} = 5.5V$ , $V_O = 0.4V$			-20	$\mu A$	
$I_{CCH}$	Supply Current	DM74ALS257	$V_{CC} = 5.5V$ Outputs OPEN	Outputs HIGH	3	6	mA
		DM74ALS258			2.5	4	mA
$I_{CCL}$	Supply Current	DM74ALS257	Outputs OPEN	Outputs LOW	8	12	mA
		DM74ALS258			7	11	mA
$I_{CCZ}$	Supply Current	DM74ALS257	Outputs Disabled	Outputs Disabled	9	14	mA
		DM74ALS258			8	13	mA

### Switching Characteristics DM74ALS257

over recommended operating free air temperature range

Symbol	Parameter	Conditions	From	To	Min	Max	Units
$t_{PLH}$	Propagation Delay Time LOW-to-HIGH Level Output	$V_{CC} = 4.5V$ to $5.5V$ $C_L = 50$ pF $R_L = 500\Omega$	Data	Any Y	2	10	ns
$t_{PHL}$	Propagation Delay Time HIGH-to-LOW Level Output		Data	Any Y	2	12	ns
$t_{PLH}$	Propagation Delay Time LOW-to-HIGH Level Output		Select	Any Y	4	18	ns
$t_{PHL}$	Propagation Delay Time HIGH-to-LOW Level Output		Select	Any Y	5	22	ns
$t_{ZH}$	Output Enable Time to HIGH Level		Output Control	Any Y	4	16	ns
$t_{ZL}$	Output Enable Time to LOW Level		Output Control	Any Y	5	18	ns
$t_{HZ}$	Output Disable Time from HIGH Level		Output Control	Any Y	2	10	ns
$t_{LZ}$	Output Disable Time from LOW Level		Output Control	Any Y	3	15	ns

### Switching Characteristics DM74ALS258

over recommended operating free air temperature range

Symbol	Parameter	Conditions	From	To	Min	Max	Units
$t_{PLH}$	Propagation Delay Time LOW-to-HIGH Level Output	$V_{CC} = 4.5V$ to $5.5V$ $C_L = 50$ pF $R_L = 500\Omega$	Data	Any Y	2	8	ns
$t_{PHL}$	Propagation Delay Time HIGH-to-LOW Level Output		Data	Any Y	2	7	ns
$t_{PLH}$	Propagation Delay Time LOW-to-HIGH Level Output		Select	Any Y	3	20	ns
$t_{PHL}$	Propagation Delay Time HIGH-to-LOW Level Output		Select	Any Y	5	25	ns
$t_{ZH}$	Output Enable Time to HIGH Level		Output Control	Any Y	5	18	ns
$t_{ZL}$	Output Enable Time to LOW Level		Output Control	Any Y	5	18	ns
$t_{HZ}$	Output Disable Time from HIGH Level		Output Control	Any Y	2	10	ns
$t_{LZ}$	Output Disable Time from LOW Level		Output Control	Any Y	3	18	ns

**Physical Dimensions** inches (millimeters) unless otherwise noted

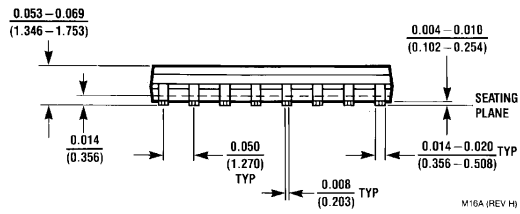
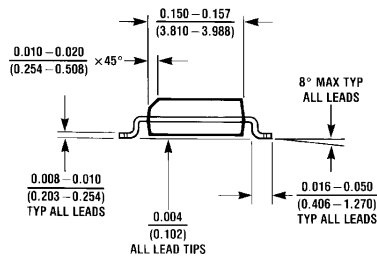
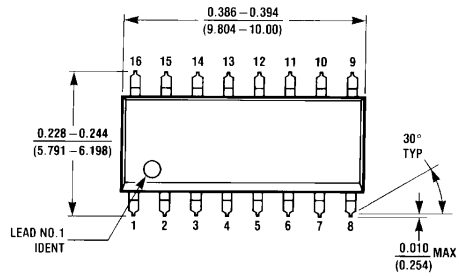

**16-Lead Small Outline Integrated Circuit (SOIC), JEDEC MS-012, 0.150 Narrow  
Package Number M16A**

**Physical Dimensions** inches (millimeters) unless otherwise noted (Continued)

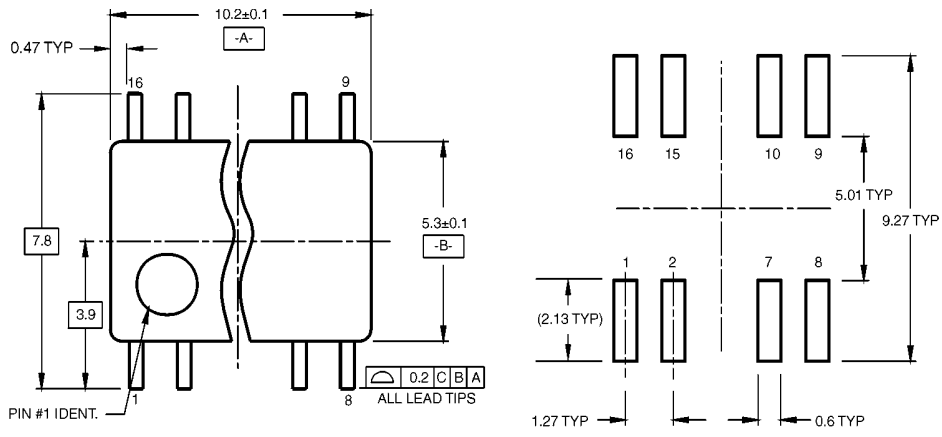

LAND PATTERN RECOMMENDATION

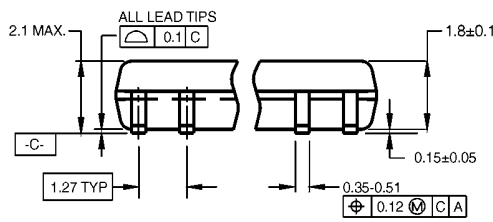

DIMENSIONS ARE IN MILLIMETERS

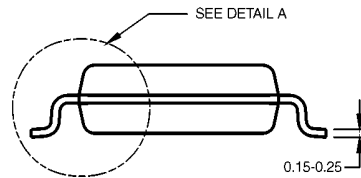

- NOTES:  
 A. CONFORMS TO EIAJ EDR-7320 REGISTRATION, ESTABLISHED IN DECEMBER, 1998.  
 B. DIMENSIONS ARE IN MILLIMETERS.  
 C. DIMENSIONS ARE EXCLUSIVE OF BURRS, MOLD FLASH, AND TIE BAR EXTRUSIONS.

M16DRevB1

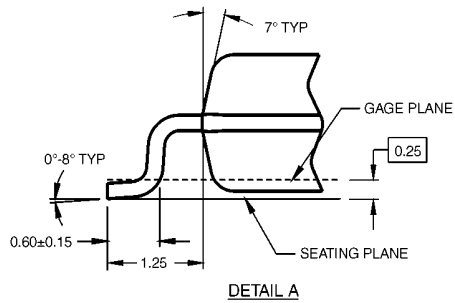

**16-Lead Small Outline Package (SOP), EIAJ TYPE II, 5.3mm Wide  
 Package Number M16D**

