

DM74ALS645A Octal Bus Transceivers

General Description

These octal bus transceivers are designed for asynchronous two-way communication between data busses. These devices transmit data from the A bus to the B bus or from the B bus to the A bus depending upon the level at the direction control (DIR) input. The enable input (G) can be used to disable the device so the busses are effectively isolated.

Features

- Advanced Oxide-isolated Ion-implanted Schottky TTL process
- Switching performance is guaranteed over full temperature and V_{CC} supply range
- Switching performance specified at 50 pF
- PNP input design reduces input loading

Ordering Code:

| Order Number | Package Number | Package Description |
|---------------|----------------|---|
| DM74ALS645AWM | M20B | 20-Lead Small Outline Integrated Circuit (SOIC), JEDEC MS-013, 0.300 Wide |
| DM74ALS645AN | N20A | 20-Lead Plastic Dual-In-Line Package (PDIP), JEDEC MS-001, 0.300 Wide |

Devices also available in Tape and Reel. Specify by appending the suffix letter "X" to the ordering code.

Connection Diagram

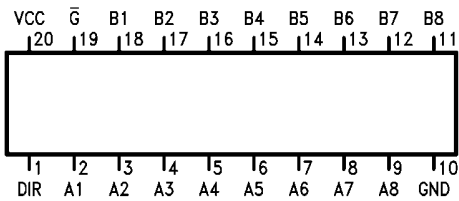

Logic Diagram

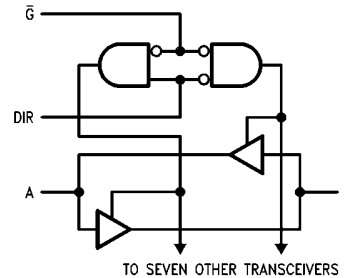

Function Table

| Control Inputs | | Operation |
|----------------|-----|-----------------|
| \bar{G} | DIR | |
| L | L | B Data to A Bus |
| L | H | A Data to B Bus |
| H | X | Isolation |

L = LOW Logic Level
H = HIGH Logic Level
X = Either LOW or HIGH Logic Level

Absolute Maximum Ratings(Note 1)

| | |
|--------------------------------------|-----------------|
| Supply Voltage | 7V |
| Input Voltage; | |
| Control Inputs | 7V |
| I/O Ports | 5.5V |
| Operating Free Air Temperature Range | 0°C to +70°C |
| Storage Temperature Range | -65°C to +150°C |
| Typical θ_{JA} | |
| N Package | 53.0°C/W |
| M Package | 72.0°C/W |

Note 1: The "Absolute Maximum Ratings" are those values beyond which the safety of the device cannot be guaranteed. The device should not be operated at these limits. The parametric values defined in the Electrical Characteristics tables are not guaranteed at the absolute maximum ratings. The "Recommended Operating Conditions" table will define the conditions for actual device operation.

Recommended Operating Conditions

| Symbol | Parameter | Min | Typ | Max | Units |
|----------|--------------------------------------|-----|-----|-----|-------|
| V_{CC} | Supply Voltage | 4.5 | 5 | 5.5 | V |
| V_{IH} | HIGH Level Input Voltage | 2 | | | V |
| V_{IL} | LOW Level Input Voltage | | | 0.8 | V |
| I_{OH} | HIGH Level Output Current | | | -15 | mA |
| I_{OL} | LOW Level Output Current | | | 24 | mA |
| T_A | Operating Free Air Temperature Range | 0 | | 70 | °C |

Electrical Characteristics

Over Recommended Free Air Temperature Range

| Symbol | Parameter | Test Conditions | Min | Typ | Max | Units | | |
|----------|--|---|---|--------------|------|---------------|---------------|-----|
| V_{IC} | Input Clamp Voltage | $V_{CC} = \text{Min}, I_I = -18 \text{ mA}$ | | | -1.5 | V | | |
| V_{OH} | HIGH Level Output Voltage | $V_{CC} = 4.5 \text{ to } 5.5\text{V}$ | $I_{OH} = -0.4 \text{ mA}$ | $V_{CC} - 2$ | | V | | |
| | | $V_{CC} = \text{Max}$ | $I_{OH} = -3 \text{ mA}$ | 2.4 | 3.2 | | | |
| | | | $I_{OH} = \text{Max}$ | 2 | | | | |
| V_{OL} | LOW Level Output Voltage | $V_{CC} = \text{Min}$ | $I_{OL} = 12 \text{ mA}$ | | 0.25 | 0.4 | V | |
| | | | $I_{OL} = 24 \text{ mA}$ | | | 0.35 | | 0.5 |
| | | | | | | | | |
| I_I | Input Current at Maximum Input Voltage | $V_{CC} = \text{Max}$ | I/O Ports, $V_I = 5.5\text{V}$ Control Inputs, $V_I = 7\text{V}$ | | 100 | 100 | μA | |
| I_{IH} | HIGH Level Input Current | $V_{CC} = \text{Max}, V_I = 2.7\text{V}$ (Note 2) | | | 20 | μA | | |
| I_{IL} | LOW Level Input Current | $V_{CC} = \text{Max}, V_I = 0.4\text{V}$ (Note 2) | | | -100 | μA | | |
| I_O | Output Drive Current | $V_{CC} = \text{Max}, V_O = 2.25\text{V}$ | | | -30 | -112 | mA | |
| I_{CC} | Supply Current | $V_{CC} = \text{Max}$ | Outputs HIGH | | 30 | 45 | mA | |
| | | | Outputs LOW | | 36 | 55 | | |
| | | | Outputs Disabled | | 38 | 58 | | |

Note 2: For I/O ports, I_{IH} and I_{IL} parameters include the 3-STATE output current (I_{OZL} and I_{OZH}).

Switching Characteristics

Over Recommended Operating Free Air Temperature Range

| Symbol | Parameter | From (Input) | To (Output) | Conditions | Min | Max | Units |
|-----------|--|--------------|-------------|--|-----|-----|-------|
| t_{PLH} | Propagation Delay Time LOW-to-HIGH Level Output | A or B | B or A | $V_{CC} = 4.5 \text{ to } 5.5\text{V},$ $C_L = 50 \text{ pF},$ $R1 = R2 = 500\Omega$ | 3 | 10 | ns |
| t_{PHL} | Propagation Delay Time HIGH-to-LOW Level Output | A or B | B or A | | 3 | 10 | ns |
| t_{PZH} | Output Enable Time to HIGH Level Output | \bar{G} | A or B | | 5 | 20 | ns |
| t_{PZL} | Output Enable Time to LOW Level Output | \bar{G} | A or B | | 5 | 20 | ns |
| t_{PHZ} | Output Disable Time from HIGH Level Output | \bar{G} | A or B | | 2 | 10 | ns |
| t_{PLZ} | Output Disable Time from LOW Level Output | \bar{G} | A or B | | 4 | 15 | ns |

Physical Dimensions inches (millimeters) unless otherwise noted

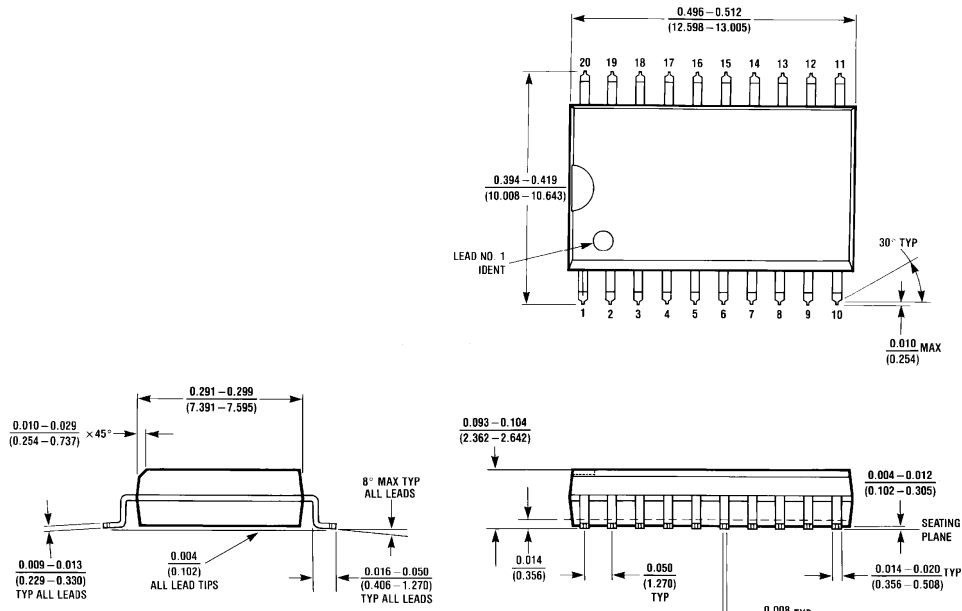

**20-Lead Small Outline Integrated Circuit (SOIC), JEDEC MS-013, 0.300 Wide
Package Number M20B**

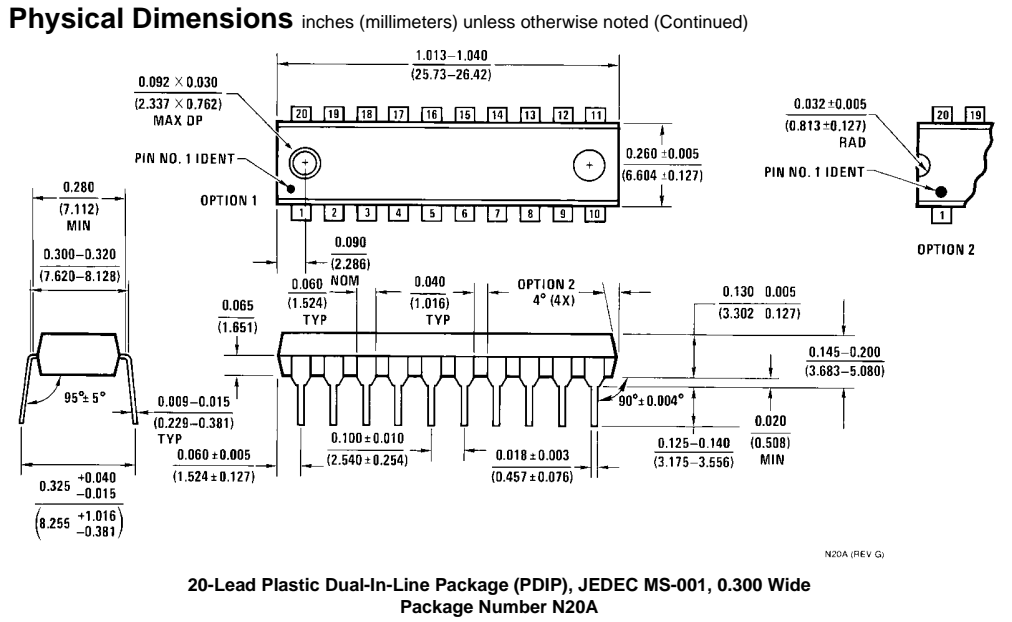

Fairchild does not assume any responsibility for use of any circuitry described, no circuit patent licenses are implied and Fairchild reserves the right at any time without notice to change said circuitry and specifications.

LIFE SUPPORT POLICY

FAIRCHILD'S PRODUCTS ARE NOT AUTHORIZED FOR USE AS CRITICAL COMPONENTS IN LIFE SUPPORT DEVICES OR SYSTEMS WITHOUT THE EXPRESS WRITTEN APPROVAL OF THE PRESIDENT OF FAIRCHILD SEMICONDUCTOR CORPORATION. As used herein:

1. Life support devices or systems are devices or systems which, (a) are intended for surgical implant into the body, or (b) support or sustain life, and (c) whose failure to perform when properly used in accordance with instructions for use provided in the labeling, can be reasonably expected to result in a significant injury to the user.
2. A critical component in any component of a life support device or system whose failure to perform can be reasonably expected to cause the failure of the life support device or system, or to affect its safety or effectiveness.

www.fairchildsemi.com