

DM74LS574

Octal D-Type Flip-Flop with 3-STATE Outputs

General Description

The DM74LS574 is a high speed low power octal flip-flop with a buffered common Clock (CP) and a buffered common Output Enable (\overline{OE}). The information presented to the D inputs is stored in the flip-flops on the LOW-to-HIGH Clock (CP) transition.

This device is functionally identical to the DM74LS374 except for the pinouts.

Ordering Code:

Order Number	Package Number	Package Description
DM74LS574WM	M20B	20-Lead Small Outline Integrated Circuit (SOIC), JEDEC MS-013, 0.300 Wide
DM74LS574N	N20A	20-Lead Plastic Dual-In-Line Package (PDIP), JEDEC MS-001, 0.300 Wide

Devices also available in Tape and Reel. Specify by appending the suffix letter "X" to the ordering code.

Logic Symbol

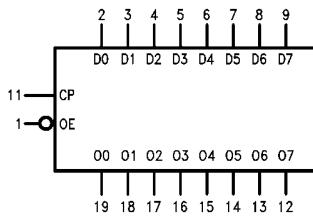

V_{CC} = Pin 20
GND = Pin 10

Connection Diagram

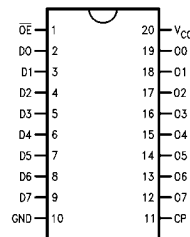

Truth Table

Inputs		Outputs	
Dn	CP	OE	On
H	↗	L	H
L	↗	L	L
X	X	H	Z

H = HIGH Voltage Level
L = LOW Voltage Level
X = Immaterial
Z = High Impedance
↗ = HIGH-to-LOW Clock (CP) transition

Functional Description

The DM74LS574 consists of eight edge-triggered flip-flops with individual D-type inputs and 3-STATE true outputs. The buffered clock and buffered Outputs Enable are common to all flip-flops. The eight flip-flops will store the state of their individual D inputs that meet the setup and hold times requirements on the LOW-to-HIGH Clock (CP) tran-

sition. With the Output Enable (\overline{OE}) LOW, the contents of the eight flip-flops are available at the outputs. When the \overline{OE} is HIGH, the outputs go to the high impedance state. Operation of the \overline{OE} input does not affect the state of the flip-flops.

Logic Diagram

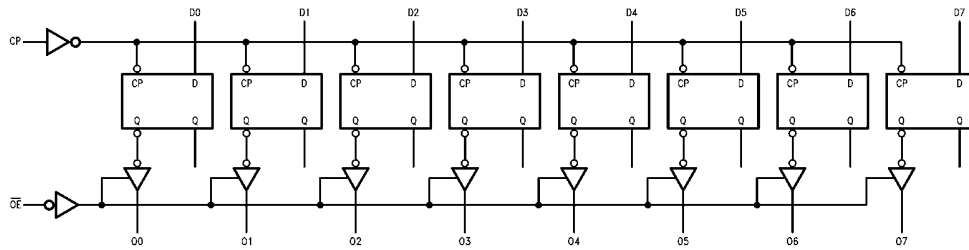

Absolute Maximum Ratings(Note 1)

Supply Voltage	7V
Input Voltage	7V
Operating Free Air Temperature Range	0°C to +70°C
Storage Temperature Range	-65°C to +150°C

Note 1: The "Absolute Maximum Ratings" are those values beyond which the safety of the device cannot be guaranteed. The device should not be operated at these limits. The parametric values defined in the Electrical Characteristics tables are not guaranteed at the absolute maximum ratings. The "Recommended Operating Conditions" table will define the conditions for actual device operation.

Recommended Operating Conditions

Symbol	Parameter	Min	Nom	Max	Units
V_{CC}	Supply Voltage	4.75	5	5.25	V
V_{IH}	HIGH Level Input Voltage	2			V
V_{IL}	LOW Level Input Voltage			0.8	V
I_{OH}	HIGH Level Output Current			-2.6	mA
I_{OL}	LOW Level Output Current			24	mA
T_A	Free Air Operating Temperature	0		70	°C
t_S (H)	Setup Time HIGH or LOW	20			ns
t_S (L)	Dn to CP	20			ns
t_H (H)	Hold Time HIGH or LOW	0			ns
t_H (L)	Dn to CP	0			ns
t_W (H)	CP Pulse Width	15			ns
t_W (L)	HIGH or LOW	15			ns

Electrical Characteristics

over recommended operating free air temperature range (unless otherwise noted)

Symbol	Parameter	Conditions	Min	Typ (Note 2)	Max	Units
V_I	Input Clamp Voltage	$V_{CC} = \text{Min}, I_I = -18 \text{ mA}$			-1.5	V
V_{OH}	HIGH Level Output Voltage	$V_{CC} = \text{Min}, I_{OH} = \text{Max}, V_{IL} = \text{Max}, V_{IH} = \text{Min}$	2.4	3.3		V
V_{OL}	LOW Level Output Voltage	$V_{CC} = \text{Min}, I_{OL} = \text{Max}, V_{IL} = \text{Max}, V_{IH} = \text{Min}, I_{OL} = 12 \text{ mA}, V_{CC} = \text{Min}$		0.35 0.25	0.5 0.4	V
I_I	Input Current @ Max Input Voltage	$V_{CC} = \text{Max}, V_I = 7V$			0.1	mA
I_{IH}	HIGH Level Input Current	$V_{CC} = \text{Max}, V_I = 2.7V$			20	μA
I_{IL}	LOW Level Input Current	$V_{CC} = \text{Max}, V_I = 0.4V$			-400	μA
I_{OZH}	OFF-State Output Current with HIGH Level Output Voltage Applied	$V_{CC} = \text{Max}, V_O = 2.4V, V_{IH} = \text{Min}, V_{IL} = \text{Max}$			20	μA
I_{OZL}	OFF-State Output Current with LOW Level Output Voltage Applied	$V_{CC} = \text{Max}, V_O = 0.4V, V_{IH} = \text{Min}, V_{IL} = \text{Max}$			-20	μA
I_{OS}	Short Circuit Output Current (Note 3)	$V_{CC} = \text{Max}$	-30		-130	mA
I_{CC}	Supply Current	$V_{CC} = \text{Max}$ (Note 4)			45	mA

Note 2: All typicals are at $V_{CC} = 5V, T_A = 25^\circ\text{C}$.

Note 3: Not more than one output should be shorted at a time, and the duration should not exceed one second.

Note 4: I_{CC} is measured with the DATA inputs grounded and the OUTPUT CONTROLS at 4.5V.

DM74LS574

Switching Characteristics $V_{CC} = +5.0V, T_A = +25^{\circ}C$

Symbol	Parameter	$R_L = 2\text{ k}\Omega, C_L = 45\text{ pF}$		Units
		Min	Max	
f_{MAX}	Maximum Clock Frequency	35		MHz
t_{PLH}	Propagation Delay		28	ns
t_{PHL}	CP to On		28	
t_{PZH}	Output Enable Time		28	ns
t_{PZL}			28	
t_{PHZ}	Output Disable Time		20	ns
t_{PLZ}			25	

Physical Dimensions inches (millimeters) unless otherwise noted

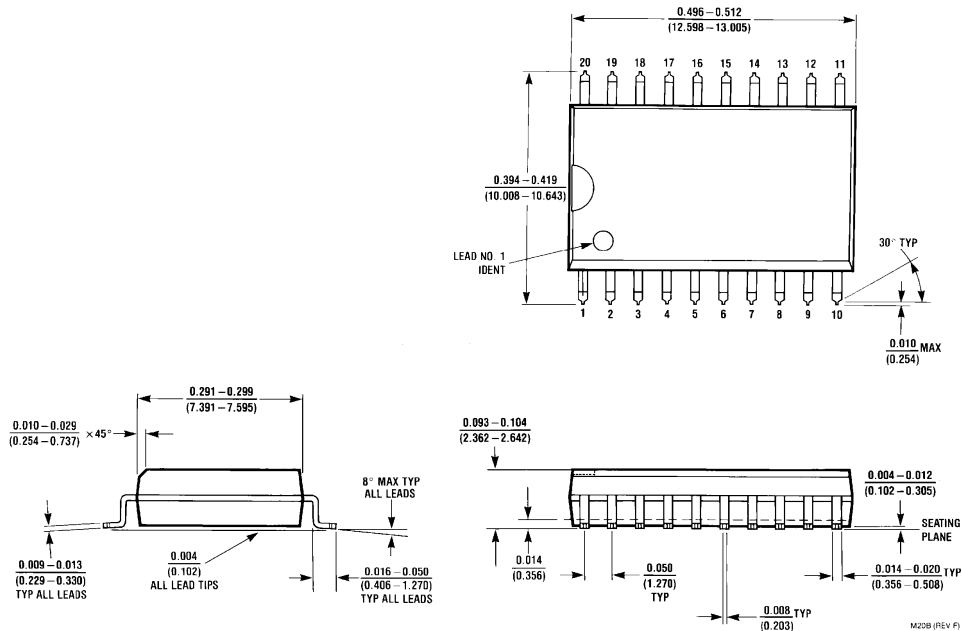

20-Lead Small Outline Integrated Circuit (SOIC), JEDEC MS-013, 0.300 Wide Package Number M20B

M20B (REV F)

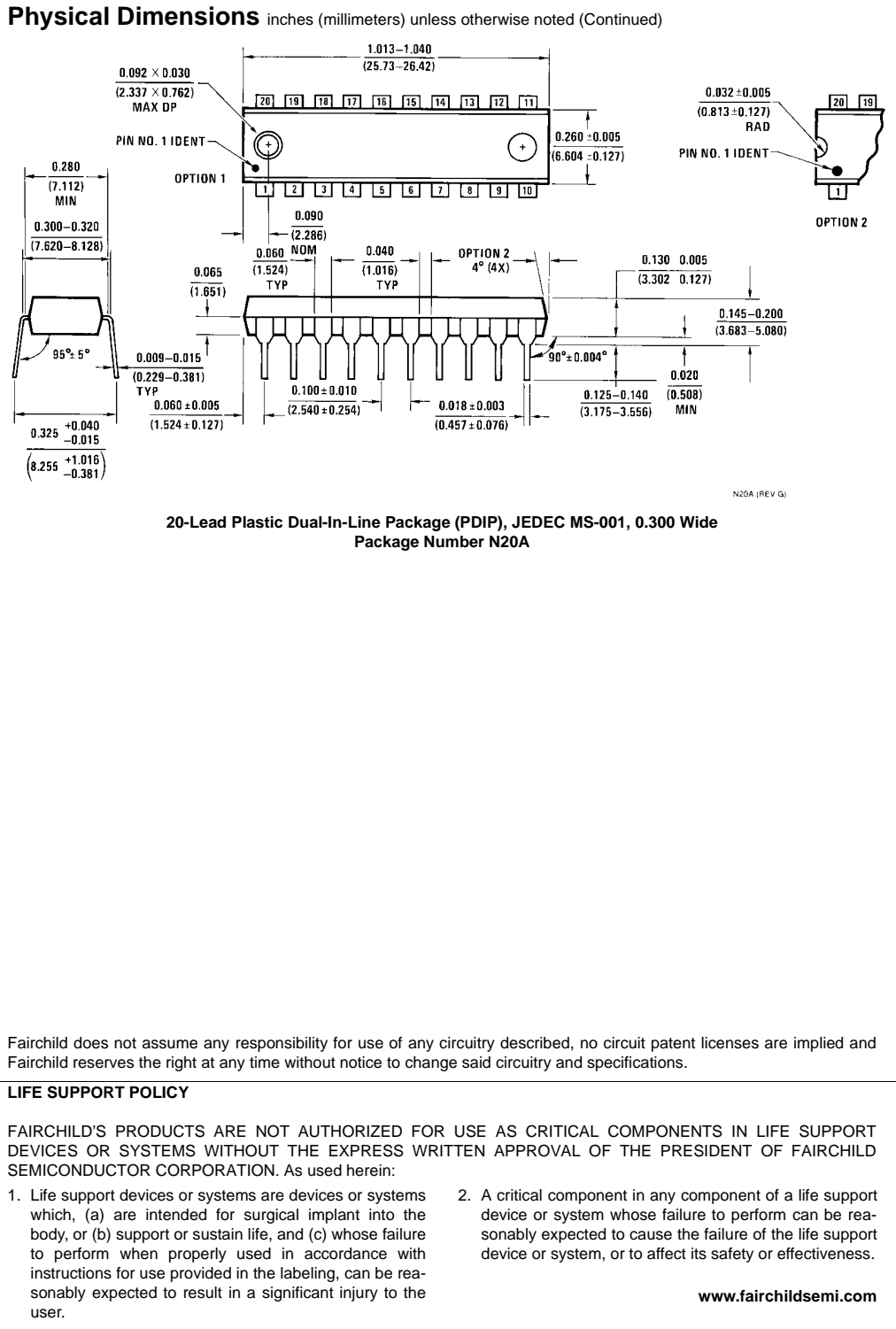

Fairchild does not assume any responsibility for use of any circuitry described, no circuit patent licenses are implied and Fairchild reserves the right at any time without notice to change said circuitry and specifications.

LIFE SUPPORT POLICY

FAIRCHILD'S PRODUCTS ARE NOT AUTHORIZED FOR USE AS CRITICAL COMPONENTS IN LIFE SUPPORT DEVICES OR SYSTEMS WITHOUT THE EXPRESS WRITTEN APPROVAL OF THE PRESIDENT OF FAIRCHILD SEMICONDUCTOR CORPORATION. As used herein:

1. Life support devices or systems are devices or systems which, (a) are intended for surgical implant into the body, or (b) support or sustain life, and (c) whose failure to perform when properly used in accordance with instructions for use provided in the labeling, can be reasonably expected to result in a significant injury to the user.
2. A critical component in any component of a life support device or system whose failure to perform can be reasonably expected to cause the failure of the life support device or system, or to affect its safety or effectiveness.

www.fairchildsemi.com