

## DM81LS95A • DM81LS96A • DM81LS97A 3-STATE Octal Buffer

### General Description

These devices provide eight, two-input buffers in each package. All employ low-power-Schottky TTL technology. One of the two inputs to each buffer is used as a control line to gate the output into the high-impedance state, while the other input passes the data through the buffer. The DM81LS95A and DM81LS97A present true data at the outputs, while the DM81LS96A is inverting. On the DM81LS95A and DM81LS96A versions, all eight 3-STATE enable lines are common, with access through a 2-input NOR gate. On the DM81LS97A version, four buffers are enabled from one common line, and the other four buffers are enabled from another common line. In all cases the outputs are placed in the 3-STATE condition by applying a high logic level to the enable pins.

### Features

- Typical power dissipation
 

DM81LS95A, DM81LS97A	80 mW
DM81LS96A	65 mW
- Typical propagation delay
 

DM81LS95A, DM81LS97A	15 ns
DM81LS96A	10 ns
- Low power-Schottky, 3-STATE technology

### Ordering Code:

Order Number	Package Number	Package Description
DM81LS95AWM	M20B	20-Lead Small Outline Integrated Circuit (SOIC), JEDEC MS-013, 0.300 Wide
DM81LS95AN	N20A	20-Lead Plastic Dual-In-Line Package (PDIP), JEDEC MS-001, 0.300 Wide
DM81LS96AWM	M20B	20-Lead Small Outline Integrated Circuit (SOIC), JEDEC MS-013, 0.300 Wide
DM81LS96AN	N20A	20-Lead Plastic Dual-In-Line Package (PDIP), JEDEC MS-001, 0.300 Wide
DM81LS97AN	N20A	20-Lead Plastic Dual-In-Line Package (PDIP), JEDEC MS-001, 0.300 Wide

Devices also available in Tape and Reel. Specify by appending the suffix letter "X" to the ordering code.

### Connection Diagram

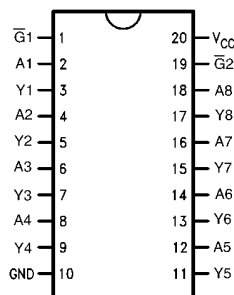

### Pin Descriptions

#### DM81LS95A and DM92LS96A

Pin Names	Descriptions
A1–A8	Inputs
Y1–Y8	Outputs
$\bar{G}1$ – $\bar{G}2$	Active LOW Output Enables (Note 1)

Note 1: Both  $\bar{G}1$  and  $\bar{G}2$  must be LOW for outputs to be enabled.

#### DM81LS97A

Pin Names	Descriptions
A1–A8	Inputs
Y1–Y8	Outputs
$\bar{G}1$	Active LOW Output Enable (Y1–Y4)
$\bar{G}2$	Active LOW Output Enable (Y5–Y8)

**Logic Symbols**

**DM81LS95A**

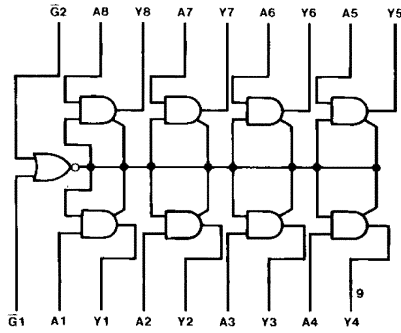

**DM81LS96A**

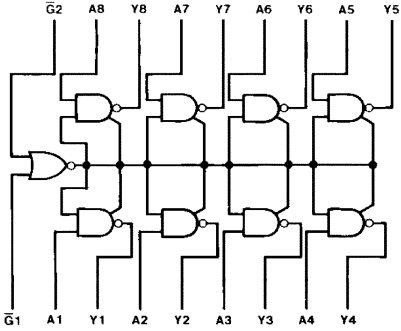

**DM81LS97A**

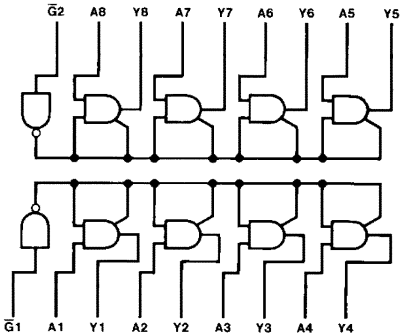

**Truth Tables**

**DM81LS95A**

Inputs			Output
$\overline{G1}$	$\overline{G2}$	A	Y
H	X	X	Hi-Z
X	H	X	Hi-Z
L	L	H	H
L	L	L	L

**DM81LS96A**

Inputs			Output
$\overline{G1}$	$\overline{G2}$	A	Y
H	X	X	Hi-Z
X	H	X	Hi-Z
L	L	H	L
L	L	L	H

**DM81LS97A**

Inputs		Output
$\overline{G1}$	A1-A4	Y1-Y4
H	X	Hi-Z
L	H	H
L	L	L
$\overline{G2}$	A5-A6	Y5-Y8
H	X	Hi-Z
L	H	H
L	L	L

**Absolute Maximum Ratings**(Note 2)

Supply Voltage	7V
Input Voltage	7V
Operating Free Air Temperature Range	0°C to +70°C
Storage Temperature Range	-65°C to +150°C

**Note 2:** The Absolute Maximum Ratings are those values beyond which the safety of the device cannot be guaranteed. The device should not be operated at these limits. The parametric values defined in the Electrical Characteristics tables are not guaranteed at the absolute maximum ratings. The Recommended Operating Conditions table will define the conditions for actual device operation.

**Recommended Operating Conditions**

Symbol	Parameter	Min	Nom	Max	Units
V <sub>CC</sub>	Supply Voltage	4.75	5	5.25	V
V <sub>IH</sub>	HIGH Level Input Voltage	2			V
V <sub>IL</sub>	LOW Level Input Voltage			0.8	V
I <sub>OH</sub>	HIGH Level Output Current			-5.2	mA
I <sub>OL</sub>	LOW Level Output Current			24	mA
T <sub>A</sub>	Free Air Operating Temperature	0		70	°C

DC Electrical Characteristics DM81LS95A and DM81LS97A						
over recommended operating free air temperature range (unless otherwise noted)						
Symbol	Parameter	Conditions	Min	Typ (Note 3)	Max	Units
$V_I$	Input Clamp Voltage	$V_{CC} = \text{Min}, I_I = -18 \text{ mA}$			-1.5	V
$V_{OH}$	HIGH Level Output Voltage	$V_{CC} = \text{Min}, I_{OH} = \text{Max}$ $V_{IL} = \text{Max}, V_{IH} = \text{Min}$	2.7			V
$V_{OL}$	LOW Level Output Voltage	$V_{CC} = \text{Min}, I_{OL} = \text{Max}$ $I_{OL} = \text{Max}, V_{IH} = \text{Min}$			0.5	V
		$I_{OL} = 12 \text{ mA}, V_{CC} = \text{Min}$			0.4	
$I_I$	Input Current @ Max Input Voltage	$V_{CC} = \text{Max}, V_I = 7\text{V}$			0.1	mA
$I_{IH}$	HIGH Level Input Current	$V_{CC} = \text{Max}, V_I = 2.7\text{V}$			20	$\mu\text{A}$
$I_{IL}$	LOW Level Input Current	$V_{CC} = \text{Max}$ $V_I = 0.5\text{V}$		A (Note 4)	-20	$\mu\text{A}$
		$V_I = 0.4\text{V}$		A (Note 5)	-50	
		$\bar{G}$			-50	
$I_{OZH}$	Off-State Output Current with HIGH Level Output Voltage Applied	$V_{CC} = \text{Max}, V_O = 2.4\text{V}$ $V_{IH} = \text{Min}, V_{IL} = \text{Max}$			20	$\mu\text{A}$
$I_{OZL}$	Off-State Output Current with LOW Level Output Voltage Applied	$V_{CC} = \text{Max}, V_O = 0.4\text{V}$ $V_{IH} = \text{Min}, V_{IL} = \text{Max}$			-20	$\mu\text{A}$
$I_{OS}$	Short Circuit Output Current	$V_{CC} = \text{Max}$ (Note 6)	-20		-100	mA
$I_{CC}$	Supply Current	$V_{CC} = \text{Max}$ (Note 4)		16	26	mA
<p><b>Note 3:</b> All typicals are at <math>V_{CC} = 5\text{V}, T_A = 25^\circ\text{C}</math>.</p> <p><b>Note 4:</b> Both <math>\bar{G}</math> inputs are at 2V.</p> <p><b>Note 5:</b> Both <math>\bar{G}</math> inputs are at 0.4V.</p> <p><b>Note 6:</b> Not more than one output should be shorted at a time, and the duration should not exceed one second.</p>						
AC Electrical Characteristics DM81LS95A and DM81LS97A						
$V_{CC} = 5\text{V}, T_A = 25^\circ\text{C}$						
Symbol	Parameter	$R_L = 667 \Omega$				Units
		$C_L = 50 \text{ pF}$		$C_L = 150 \text{ pF}$		
		Min	Max	Min	Max	
$t_{PLH}$	Propagation Delay Time LOW-to-HIGH Level Output		16		25	ns
$t_{PHL}$	Propagation Delay Time HIGH-to-LOW Level Output		28		40	ns
$t_{PZH}$	Output Enable Time to HIGH Level Output		25		30	ns
$t_{PZL}$	Output Enable Time to LOW Level Output		30		42	ns
$t_{PHZ}$	Output Disable Time from HIGH Level Output (Note 7)		20			ns
$t_{PLZ}$	Output Disable Time from LOW Level Output (Note 7)		27			ns
<b>Note 7:</b> $C_L = 5 \text{ pF}$ .						

DC Electrical Characteristics DM81LS96A							
over recommended operating free air temperature range (unless otherwise noted)							
Symbol	Parameter	Conditions	Min	Typ (Note 8)	Max	Units	
$V_I$	Input Clamp Voltage	$V_{CC} = \text{Min}, I_I = -18 \text{ mA}$			-1.5	V	
$V_{OH}$	HIGH Level Output Voltage	$V_{CC} = \text{Min}, I_{OH} = \text{Max}$ $V_{IL} = \text{Max}, V_{IH} = \text{Min}$	2.7			V	
$V_{OL}$	LOW Level Output Voltage	$V_{CC} = \text{Min}, I_{OL} = \text{Max}$ $I_{OL} = \text{Max}, V_{IH} = \text{Min}$			0.5	V	
		$I_{OL} = 12 \text{ mA}, V_{CC} = \text{Min}$			0.4		
$I_I$	Input Current @ Max Input Voltage	$V_{CC} = \text{Max}, V_I = 7V$			0.1	mA	
$I_{IH}$	HIGH Level Input Current	$V_{CC} = \text{Max}, V_I = 2.7V$			20	$\mu\text{A}$	
$I_{IL}$	LOW Level Input Current	$V_{CC} = \text{Max}$	$V_I = 0.5V$	A (Note 9)		-20	$\mu\text{A}$
			$V_I = 0.4V$	A (Note 10)		-50	
			$\overline{G}$			-50	
$I_{OZH}$	Off-State Output Current with HIGH Level Output Voltage Applied	$V_{CC} = \text{Max}, V_O = 2.4V$ $V_{IH} = \text{Min}, V_{IL} = \text{Max}$			20	$\mu\text{A}$	
$I_{OZL}$	Off-State Output Current with LOW Level Output Voltage Applied	$V_{CC} = \text{Max}, V_O = 0.4V$ $V_{IH} = \text{Min}, V_{IL} = \text{Max}$			-20	$\mu\text{A}$	
$I_{OS}$	Short Circuit Output Current	$V_{CC} = \text{Max}$ (Note 11)	-20		-100	mA	
$I_{CC}$	Supply Current	$V_{CC} = \text{Max}$ (Note 10)		13	21	mA	
<p><b>Note 8:</b> All typicals are at <math>V_{CC} = 5V, T_A = 25^\circ\text{C}</math>.</p> <p><b>Note 9:</b> Both <math>\overline{G}</math> inputs are at 2V.</p> <p><b>Note 10:</b> Both <math>\overline{G}</math> inputs are at 0.4V.</p> <p><b>Note 11:</b> Not more than one output should be shorted at a time, and the duration should not exceed one second.</p>							
AC Electrical Characteristics DM81LS96A							
$V_{CC} = 5V, T_A = 25^\circ\text{C}$							
Symbol	Parameter	$R_L = 667 \Omega$				Units	
		$C_L = 50 \text{ pF}$		$C_L = 150 \text{ pF}$			
		Min	Max	Min	Max		
$t_{PLH}$	Propagation Delay Time LOW-to-HIGH Level Output		10		16	ns	
$t_{PHL}$	Propagation Delay Time HIGH-to-LOW Level Output		17		30	ns	
$t_{PZH}$	Output Enable Time to HIGH Level Output		15		30	ns	
$t_{PZL}$	Output Enable Time to LOW Level Output		35		45	ns	
$t_{PHZ}$	Output Disable Time from HIGH Level Output (Note 12)		20			ns	
$t_{PLZ}$	Output Disable Time from LOW Level Output (Note 12)		27			ns	
<b>Note 12:</b> $C_L = 5 \text{ pF}$ .							

**Physical Dimensions** inches (millimeters) unless otherwise noted

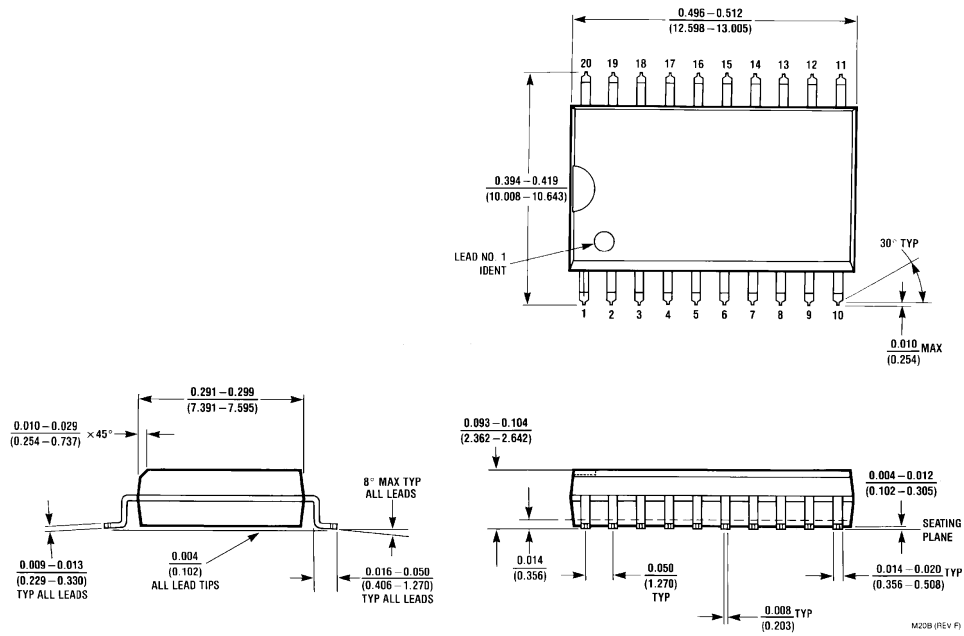

**20-Lead Small Outline Integrated Circuit (SOIC), JEDEC MS-013, 0.300 Wide  
Package Number M20B**

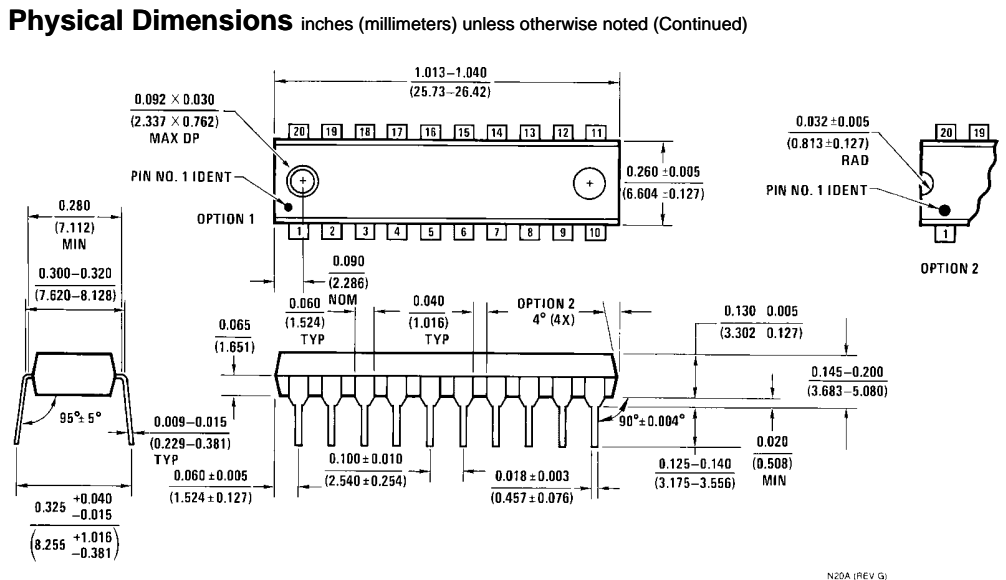

**20-Lead Plastic Dual-In-Line Package (PDIP), JEDEC MS-001, 0.300 Wide  
Package Number N20A**

Fairchild does not assume any responsibility for use of any circuitry described, no circuit patent licenses are implied and Fairchild reserves the right at any time without notice to change said circuitry and specifications.

**LIFE SUPPORT POLICY**

FAIRCHILD'S PRODUCTS ARE NOT AUTHORIZED FOR USE AS CRITICAL COMPONENTS IN LIFE SUPPORT DEVICES OR SYSTEMS WITHOUT THE EXPRESS WRITTEN APPROVAL OF THE PRESIDENT OF FAIRCHILD SEMICONDUCTOR CORPORATION. As used herein:

1. Life support devices or systems are devices or systems which, (a) are intended for surgical implant into the body, or (b) support or sustain life, and (c) whose failure to perform when properly used in accordance with instructions for use provided in the labeling, can be reasonably expected to result in a significant injury to the user.
2. A critical component in any component of a life support device or system whose failure to perform can be reasonably expected to cause the failure of the life support device or system, or to affect its safety or effectiveness.

[www.fairchildsemi.com](http://www.fairchildsemi.com)