

MM74C906 • MM74C907

Hex Open Drain N-Channel Buffers • Hex Open Drain P-Channel Buffers

General Description

The MM74C906 and MM74C907 buffers employ monolithic CMOS technology in achieving open drain outputs. The MM74C906 consists of six inverters driving six N-channel devices; and the MM74C907 consists of six inverters driving six P-channel devices. The open drain feature of these buffers makes level shifting or wire AND and wire OR functions by just the addition of pull-up or pull-down resistors.

All inputs are protected from static discharge by diode clamps to V_{CC} and to ground.

Features

- Wide supply voltage range: 3V to 15V
- Guaranteed noise margin: 1V
- High noise immunity: $0.45 V_{CC}$ (typ.)
- High current sourcing and sinking open drain outputs

Ordering Code:

Order Number	Package Number	Package Description
MM74C906M	M14A	14-Lead Small Outline Integrated Circuit (SOIC), JEDEC MS-120, 0.150" Narrow
MM74C906N	N14A	14-Lead Plastic Dual-In-Line Package (PDIP), JEDEC MS-001, 0.300" Wide
MM74C907N	N14A	14-Lead Plastic Dual-In-Line Package (PDIP), JEDEC MS-001, 0.300" Wide

Devices also available in Tape and Reel. Specify by appending the suffix letter "X" to the ordering code.

Connection Diagram

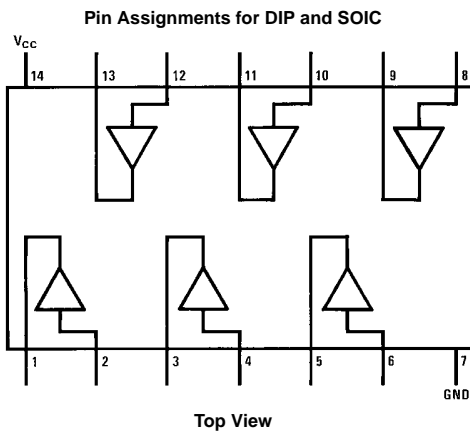

Logic Diagrams

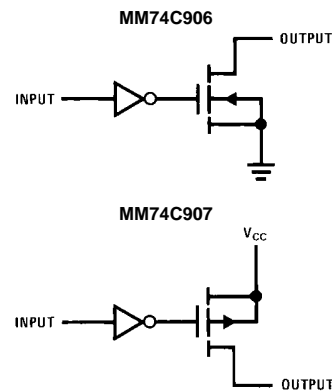

Absolute Maximum Ratings (Note 1)		Operating V_{CC} Range	3V to 15V
Voltage at Any Input Pin	-0.3V to $V_{CC} + 0.3V$	Absolute Maximum V_{CC}	18V
Voltage at Any Output Pin		Lead Temperature (T_L)	260°C
Operating Temperature Range		(Soldering, 10 seconds)	
MM74C906/MM74C907	-40°C to +85°C		
Storage Temperature Range	-65°C to +150°C		
Power Dissipation			
Dual-In-Line	700 mW		
Small Outline	500 mW		

Note 1: "Absolute Maximum Ratings" are those values beyond which the safety of the device cannot be guaranteed. Except for "Operating Temperature Range" they are not meant to imply that the devices should be operated at these limits. The table of "Electrical Characteristics" provides conditions for actual device operation.

DC Electrical Characteristics

Min/Max limits apply across temperature range unless otherwise noted

Symbol	Parameter	Conditions	Min	Typ	Max	Units
CMOS TO CMOS						
$V_{IN(1)}$	Logical "1" Input Voltage	$V_{CC} = 5V$ $V_{CC} = 10V$	3.5 8.0			V V
$V_{IN(0)}$	Logical "0" Input Voltage	$V_{CC} = 5V$ $V_{CC} = 10V$			1.5 2	V V
$I_{IN(1)}$	Logical "1" Input Current	$V_{CC} = 15V, V_{IN} = 15V$		0.005	1	μA
$I_{IN(0)}$	Logical "0" Input Current	$V_{CC} = 15V, V_{IN} = 0V$	-1.0	-0.005		μA
I_{CC}	Supply Current	$V_{CC} = 15V, \text{Output Open}$		0.05	15	μA
	Output Leakage					
	MM74C906	$V_{CC} = 4.75V, V_{IN} = V_{CC} - 1.5V$ $V_{CC} = 4.75V, V_{OUT} = 18V$		0.005	5	μA
	MM74C907	$V_{CC} = 4.75V, V_{IN} = 1V + 0.1 V_{CC}$ $V_{CC} = 4.75V, V_{OUT} = V_{CC} - 18V$		0.005	5	μA
CMOS/LPTTL INTERFACE						
$V_{IN(1)}$	Logical "1" Input Voltage	$V_{CC} = 4.75V$	$V_{CC} - 1.5V$			V
$V_{IN(0)}$	Logical "0" Input Voltage	$V_{CC} = 4.75V$			0.8	V
OUTPUT DRIVE CURRENT						
	MM74C906	$V_{CC} = 4.75V, V_{IN} = 1V + 0.1 V_{CC}$ $V_{CC} = 4.75V, V_{OUT} = 0.5V$ $V_{CC} = 4.75V, V_{OUT} = 1.0V$	2.1 4.2	8.0 12.0		mA mA
	MM74C907	$V_{CC} = 4.75V, V_{IN} = V_{CC} - 1.5V$ $V_{CC} = 4.75V, V_{OUT} = V_{CC} - 0.5V$ $V_{CC} = 4.75V, V_{OUT} = V_{CC} - 1V$	-1.05 -2.1	-1.5 -3.0		mA mA
	MM74C906	$V_{CC} = 10V, V_{IN} = 2V$ $V_{CC} = 10V, V_{OUT} = 0.5V$ $V_{CC} = 10V, V_{OUT} = 1V$	4.2 8.4	-20 -30		mA mA
	MM74C907	$V_{CC} = 10V, V_{IN} = 8V$ $V_{CC} = 10V, V_{OUT} = 9.5V$ $V_{CC} = 10V, V_{OUT} = 9V$	-2.1 -4.2	-4.0 -8.0		mA mA

AC Electrical Characteristics (Note 2)						
T _A = 25°C, C _L = 50 pF, unless otherwise specified						
Symbol	Parameter	Conditions	Min	Typ	Max	Units
t _{pd}	Propagation Delay Time to a Logical "0" MM74C906 MM74C907	V _{CC} = 5.0V, R = 10k			150	ns
		V _{CC} = 10V, R = 10k			75	ns
		V _{CC} = 5.0V (Note 3)			150 + 0.7 RC	ns
		V _{CC} = 10V (Note 3)			75 + 0.7 RC	ns
t _{pd}	Propagation Delay Time to a Logical "1" MM74C906 MM74C907	V _{CC} = 5.0V (Note 3)			150 + 0.7 RC	ns
		V _{CC} = 10V (Note 3)			75 + 0.7 RC	ns
		V _{CC} = 5.0V, R = 10k			150	ns
		V _{CC} = 10V, R = 10k			75	ns
C _{IN}	Input Capacitance	(Note 4)		5.0		pF
C _{OUT}	Output Capacity	(Note 4)		20		pF
C _{PD}	Power Dissipation Capacity	(Note 5) Per Buffer		30		pF

Note 2: AC Parameters are guaranteed by DC correlated testing.

Note 3: "C" used in calculating propagation includes output load capacity (C_L) plus device output capacity (C_{OUT}).

Note 4: Capacitance is guaranteed by periodic testing.

Note 5: C_{PD} determines the no load AC power consumption of any CMOS device. For complete explanation see Family Characteristics Application Note, AN-90. (Assumes outputs are open).

Typical Applications

Wire OR Gate

MM74C907

$f = A + B$

Wire AND Gate

MM74C906

$f = A \cdot B$

Note: Can be extended to more than 2 inputs.

CMOS or TTL to PMOS Interface

MM74C907

CMOS or TTL to CMOS at a Higher V_{CC}

MM74C906

Note: V_{CC} + V_{DD} ≤ 18V
V_{CC} ≤ 15V

Physical Dimensions inches (millimeters) unless otherwise noted

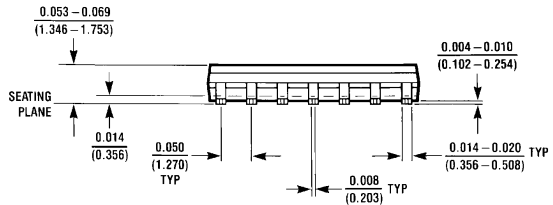
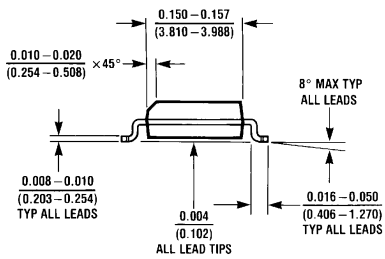
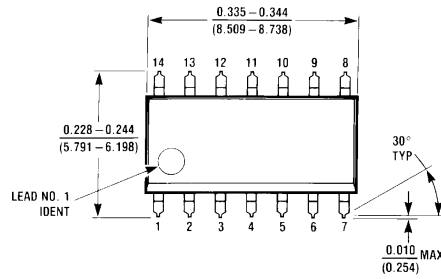

14-Lead Small Outline Integrated Circuit (SOIC), JEDEC MS-120, 0.150" Narrow
Package Number M14A

M14A (REV. H)

Physical Dimensions inches (millimeters) unless otherwise noted (Continued)

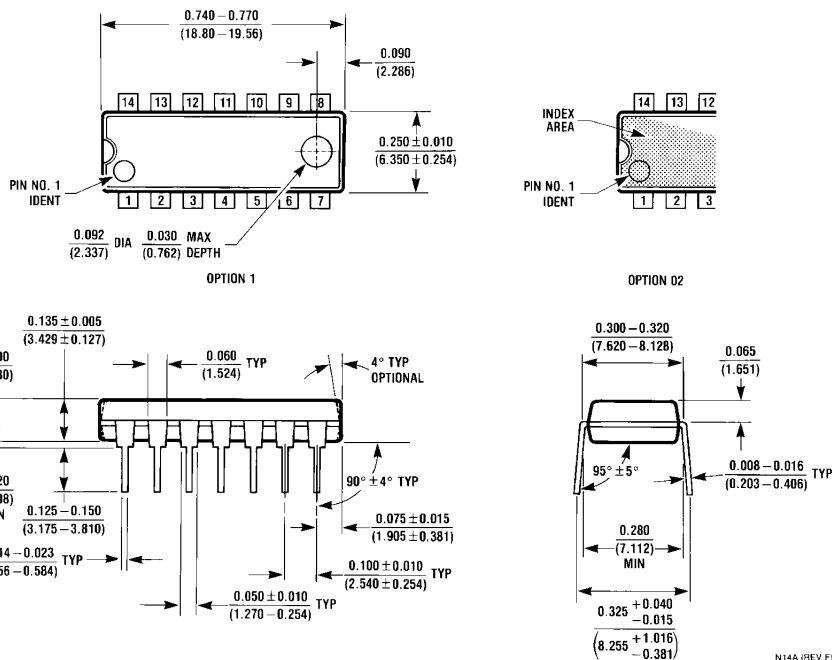

14-Lead Plastic Dual-In-Line Package (PDIP), JEDEC MS-001, 0.300" Wide Package Number N14A

LIFE SUPPORT POLICY

FAIRCHILD'S PRODUCTS ARE NOT AUTHORIZED FOR USE AS CRITICAL COMPONENTS IN LIFE SUPPORT DEVICES OR SYSTEMS WITHOUT THE EXPRESS WRITTEN APPROVAL OF THE PRESIDENT OF FAIRCHILD SEMICONDUCTOR CORPORATION. As used herein:

1. Life support devices or systems are devices or systems which, (a) are intended for surgical implant into the body, or (b) support or sustain life, and (c) whose failure to perform when properly used in accordance with instructions for use provided in the labeling, can be reasonably expected to result in a significant injury to the user.
2. A critical component in any component of a life support device or system whose failure to perform can be reasonably expected to cause the failure of the life support device or system, or to affect its safety or effectiveness.

www.fairchildsemi.com