

# MC79MXX

## 3-Terminal 0.5A Negative Voltage Regulator

### Features

- No external components required
- Output current in excess of 0.5A
- Internal thermal overload
- Internal short circuit current limiting
- Output transistor safe area compensation
- Output voltages of -5V,-6V,-8V,-12V,-15V,-18V and -24V

### Description

The MC79MXX series of 3-Terminal medium current negative voltage regulators are monolithic integrated circuits designed as fixed voltage regulators. These regulators employ internal current limiting, thermal shutdown and safe area compensation making them essentially indestructible.

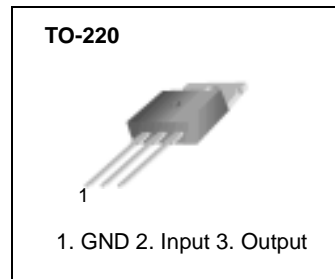

### Schematic Diagram

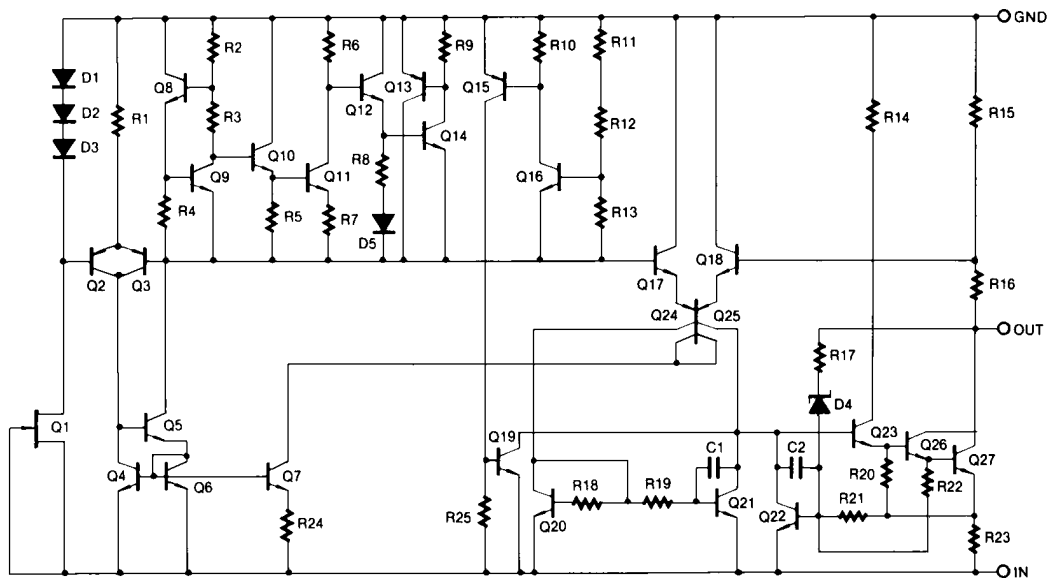

## Absolute Maximum Ratings

Parameter	Symbol	Value	Unit
Input Voltage(for $V_O = -5V$ to $-18V$ ) (for $V_O = -24V$ )	$V_I$	-35	V
	$V_I$	-40	V
Thermal Resistance Junction-Cases	$R_{\theta JC}$	5	$^{\circ}C/W$
Thermal Resistance Junction-Air	$R_{\theta JA}$	65	$^{\circ}C/W$
Operating Temperature Range	$T_{OPR}$	0 ~ +125	$^{\circ}C$
Storage Temperature Range	$T_{STG}$	-65 ~ +125	$^{\circ}C$

## Electrical Characteristics (MC79M05)

(Refer to test circuit,  $0^{\circ}C \leq T_J \leq +125^{\circ}C$ ,  $I_O = 350mA$ ,  $V_I = -10V$ , unless otherwise specified,  $C_I = 0.33\mu F$ ,  $C_O = 0.1\mu F$ )

Parameter	Symbol	Conditions	Min.	Typ.	Max.	Unit	
Output Voltage	$V_O$	$T_J = +25^{\circ}C$	-4.8	-5	-5.2	V	
		$I_O = 5mA$ to $350mA$ $V_I = -7V$ to $-25V$	-4.75	-5	-5.25		
Line Regulation (Note1)	$\Delta V_O$	$T_J = +25^{\circ}C$	$V_I = -7V$ to $-25V$	-	7.0	50	mV
			$V_I = -8V$ to $-25V$	-	2.0	30	
Load Regulation (Note1)	$\Delta V_O$	$I_O = 5mA$ to $500mA$ $T_J = +25^{\circ}C$	-	30	100	mV	
Quiescent Current	$I_Q$	$T_J = +25^{\circ}C$	-	3.0	6.0	mA	
Quiescent Current Change	$\Delta I_Q$	$I_O = 5mA$ to $350mA$	-	-	0.4	mA	
		$I_O = 200mA$ $V_I = -8V$ to $-25V$	-	-	0.4		
Output Voltage Drift	$\Delta V_O/\Delta T$	$I_O = 5mA$	-	-0.2	-	mV/ $^{\circ}C$	
Output Noise Voltage	$V_N$	$f = 10Hz, 100KHz$ $T_A = +25^{\circ}C$	-	40	-	$\mu V$	
Ripple Rejection	RR	$f = 120Hz$ $V_J = -8$ to $-18V$	54	60	-	dB	
Dropout Voltage	$V_D$	$T_J = +25^{\circ}C$ , $I_O = 500mA$	-	1.1	-	V	
Short Circuit Current	ISC	$T_J = +25^{\circ}C$ , $V_I = -35V$	-	140	-	mA	
Peak Current	IPK	$T_J = +25^{\circ}C$	-	650	-	mA	

### Note:

1. Load and line regulation are specified at constant junction temperature. Change in  $V_O$  due to heating effects must be taken into account separately. Pulse testing with low duty is used.

## Electrical Characteristics (MC79M06)

(Refer to test circuit,  $0\text{ }^{\circ}\text{C} \leq T_J \leq +125\text{ }^{\circ}\text{C}$ ,  $I_O = 350\text{mA}$ ,  $V_I = -11\text{V}$ , unless otherwise specified)

Parameter	Symbol	Conditions	Min.	Typ.	Max.	Unit	
Output Voltage	$V_O$	$T_J = +25\text{ }^{\circ}\text{C}$	- 5.75	- 6.0	- 6.25	V	
		$I_O = 5\text{mA}$ to $350\text{mA}$ $V_I = -8.0\text{V}$ to $-25\text{V}$	- 5.7	- 6.0	- 6.3		
Line Regulation (Note1)	$\Delta V_O$	$T_J = +25\text{ }^{\circ}\text{C}$	$V_I = -8\text{V}$ to $-25\text{V}$	-	7.0	60	mV
			$V_I = -9\text{V}$ to $-19\text{V}$	-	2.0	40	
Load Regulation (Note1)	$\Delta V_O$	$T_J = +25\text{ }^{\circ}\text{C}$	$I_O = 5.0\text{mA}$ to $500\text{mA}$	-	30	120	mV
Quiescent Current	$I_Q$	$T_J = +25\text{ }^{\circ}\text{C}$	-	3	6	mA	
Quiescent Current Change	$\Delta I_Q$	$I_O = 5\text{mA}$ to $350\text{mA}$	-	-	0.4	mA	
		$V_I = -8\text{V}$ to $-25\text{V}$	-	-	0.4		
Output Voltage Drift	$\Delta V_O / \Delta T$	$I_O = 5\text{mA}$	-	0.4	-	mV/ $^{\circ}\text{C}$	
Output Noise Voltage	$V_N$	$f = 10\text{Hz}$ to $100\text{kHz}$ , $T_A = +25\text{ }^{\circ}\text{C}$	-	50	-	$\mu\text{V}$	
Ripple Rejection	RR	$f = 120\text{Hz}$ , $V_I = -9\text{V}$ to $-19\text{V}$	54	60	-	dB	
Dropout Voltage	$V_D$	$I_O = 500\text{mA}$ , $T_J = +25\text{ }^{\circ}\text{C}$	-	1.1	-	V	
Short Circuit Current	ISC	$V_I = -35\text{V}$ , $T_J = +25\text{ }^{\circ}\text{C}$	-	140	-	mA	
Peak Current	IPK	$T_J = +25\text{ }^{\circ}\text{C}$	-	650	-	mA	

### Note:

1. Load and line regulation are specified at constant junction temperature. Change in  $V_O$  due to heating effects must be taken into account separately. Pulse testing with low duty is used.

## Electrical Characteristics (MC79M08)

(Refer to test circuit,  $0\text{ }^{\circ}\text{C} \leq T_J \leq +125\text{ }^{\circ}\text{C}$ ,  $I_O = 350\text{mA}$ ,  $V_I = -14\text{V}$ , unless otherwise specified)

Parameter	Symbol	Conditions	Min.	Typ.	Max.	Unit	
Output Voltage	$V_O$	$T_J = +25\text{ }^{\circ}\text{C}$	- 7.7	- 8.0	- 8.3	V	
		$I_O = 5\text{mA to } 350\text{mA}$ $V_I = -10.5\text{V to } -25\text{V}$	- 7.6	- 8.0	- 8.4		
Line Regulation (Note1)	$\Delta V_O$	$T_J = +25\text{ }^{\circ}\text{C}$	$V_I = -10.5\text{V to } -25\text{V}$	-	7.0	80	mV
			$V_I = -11\text{V to } -21\text{V}$	-	2.0	50	
Load Regulation (Note1)	$\Delta V_O$	$T_J = +25\text{ }^{\circ}\text{C}$	$I_O = 5.0\text{mA to } 500\text{mA}$	-	30	160	mV
Quiescent Current	$I_Q$	$T_J = +25\text{ }^{\circ}\text{C}$	-	3	6	mA	
Quiescent Current Change	$\Delta I_Q$	$I_O = 5\text{mA to } 350\text{mA}$	-	-	0.4	mA	
		$V_I = -8\text{V to } -25\text{V}$	-	-	0.4		
Output Voltage Drift	$\Delta V_O / \Delta T$	$I_O = 5\text{mA}$	-	-0.6	-	mV/ $^{\circ}\text{C}$	
Output Noise Voltage	$V_N$	$f = 10\text{Hz to } 100\text{kHz}$ , $T_A = +25\text{ }^{\circ}\text{C}$	-	60	-	$\mu\text{V}$	
Ripple Rejection	RR	$f = 120\text{Hz}$ , $V_I = -9\text{V to } -19\text{V}$	54	59	-	dB	
Dropout Voltage	$V_D$	$I_O = 500\text{mA}$ , $T_J = +25\text{ }^{\circ}\text{C}$	-	1.1	-	V	
Short Circuit Current	$I_{SC}$	$V_I = -35\text{V}$ , $T_J = +25\text{ }^{\circ}\text{C}$	-	140	-	mA	
Peak Current	$I_{PK}$	$T_J = +25\text{ }^{\circ}\text{C}$	-	650	-	mA	

### Note:

1. Load and line regulation are specified at constant junction temperature. Change in  $V_O$  due to heating effects must be taken into account separately. Pulse testing with low duty is used.

## Electrical Characteristics (MC79M12)

(Refer to test circuit,  $0\text{ }^{\circ}\text{C} \leq T_J \leq +125\text{ }^{\circ}\text{C}$ ,  $I_O = 350\text{mA}$ ,  $V_I = -19\text{V}$ , unless otherwise specified)

Parameter	Symbol	Conditions	Min.	Typ.	Max.	Unit	
Output Voltage	$V_O$	$T_J = +25\text{ }^{\circ}\text{C}$	-11.5	-12	-12.5	V	
		$I_O = 5\text{mA to } 350\text{mA}$ $V_I = -14.5\text{V to } -30\text{V}$	-11.4	-12	-12.6		
Line Regulation (Note1)	$\Delta V_O$	$T_J = +25\text{ }^{\circ}\text{C}$	$V_I = -14.5\text{V to } -30\text{V}$	-	8.0	80	mV
			$V_I = -15\text{V to } -25\text{V}$	-	3.0	50	
Load Regulation (Note1)	$\Delta V_O$	$T_J = +25\text{ }^{\circ}\text{C}$	$I_O = 5.0\text{mA to } 500\text{mA}$	-	30	240	mV
Quiescent Current	$I_Q$	$T_J = +25\text{ }^{\circ}\text{C}$	-	3	6	mA	
Quiescent Current Change	$\Delta I_Q$	$I_O = 5\text{mA to } 350\text{mA}$	-	-	0.4	mA	
		$V_I = -14.5\text{V to } -30\text{V}$	-	-	0.4		
Output Voltage Drift	$\Delta V_O / \Delta T$	$I_O = 5\text{mA}$	-	-0.8	-	mV/ $^{\circ}\text{C}$	
Output Noise Voltage	$V_N$	$f = 10\text{Hz to } 100\text{kHz}, T_A = +25\text{ }^{\circ}\text{C}$	-	75	-	$\mu\text{V}$	
Ripple Rejection	RR	$f = 120\text{Hz}, V_I = -15\text{V to } -25\text{V}$	54	60	-	dB	
Dropout Voltage	$V_D$	$I_O = 500\text{mA}, T_J = +25\text{ }^{\circ}\text{C}$	-	1.1	-	V	
Short Circuit Current	ISC	$V_I = -35\text{V}, T_J = +25\text{ }^{\circ}\text{C}$	-	140	-	mA	
Peak Current	IPK	$T_J = +25\text{ }^{\circ}\text{C}$	-	650	-	mA	

### Note:

1. Load and line regulation are specified at constant junction temperature. Change in  $V_O$  due to heating effects must be taken into account separately. Pulse testing with low duty is used.

## Electrical Characteristics (MC79M15)

(Refer to test circuit,  $0\text{ }^{\circ}\text{C} \leq T_J \leq +125\text{ }^{\circ}\text{C}$ ,  $I_O = 350\text{mA}$ ,  $V_I = -23\text{V}$ , unless otherwise specified)

Parameter	Symbol	Conditions	Min.	Typ.	Max.	Unit	
Output Voltage	$V_O$	$T_J = +25\text{ }^{\circ}\text{C}$	- 14.4	- 15	- 15.6	V	
		$I_O = 5\text{mA to } 350\text{mA}$ $V_I = -17.5\text{V to } -30\text{V}$	-14.25	- 15	-15.75		
Line Regulation (Note1)	$\Delta V_O$	$T_J = +25\text{ }^{\circ}\text{C}$	$V_I = -17.5\text{V to } -30\text{V}$	-	9.0	80	mV
			$V_I = -18\text{V to } -28\text{V}$	-	5.0	50	
Load Regulation (Note1)	$\Delta V_O$	$T_J = +25\text{ }^{\circ}\text{C}$	$I_O = 5.0\text{mA to } 500\text{mA}$	-	30	240	mV
Quiescent Current	$I_Q$	$T_J = +25\text{ }^{\circ}\text{C}$	-	3	6	mA	
Quiescent Current Change	$\Delta I_Q$	$I_O = 5\text{mA to } 350\text{mA}$		-	-	0.4	mA
		$V_I = -17.5\text{V to } -28\text{V}$		-	-	0.4	
Output Voltage Drift	$\Delta V_O/\Delta T$	$I_O = 5\text{mA}$		-	-1.0	-	mV/ $^{\circ}\text{C}$
Output Noise Voltage	$V_N$	$f = 10\text{Hz to } 100\text{KHz}, T_A = +25\text{ }^{\circ}\text{C}$		-	90	-	$\mu\text{V}$
Ripple Rejection	RR	$f = 120\text{Hz}, V_I = -18.5\text{V to } -28.5\text{V}$		54	59	-	dB
Dropout Voltage	$V_D$	$I_O = 500\text{mA}, T_J = +25\text{ }^{\circ}\text{C}$		-	1.1	-	V
Short Circuit Current	$I_{SC}$	$V_I = -35\text{V}, T_J = +25\text{ }^{\circ}\text{C}$		-	140	-	mA
Peak Current	$I_{PK}$	$T_J = +25\text{ }^{\circ}\text{C}$		-	650	-	mA

### Note:

1. Load and line regulation are specified at constant junction temperature. Change in  $V_O$  due to heating effects must be taken into account separately. Pulse testing with low duty is used.

## Electrical Characteristics (MC79M18)

(Refer to test circuit,  $0\text{ }^{\circ}\text{C} \leq T_J \leq +125\text{ }^{\circ}\text{C}$ ,  $I_O = 350\text{mA}$ ,  $V_I = -27\text{V}$ , unless otherwise specified)

Parameter	Symbol	Conditions	Min.	Typ.	Max.	Unit	
Output Voltage	$V_O$	$T_J = +25\text{ }^{\circ}\text{C}$	- 17.3	- 18	- 18.7	V	
		$I_O = 5\text{mA to } 350\text{mA}$ $V_I = -21\text{V to } -33\text{V}$	- 17.1	- 18	- 18.9		
Line Regulation (Note1)	$\Delta V_O$	$T_J = +25\text{ }^{\circ}\text{C}$	$V_I = -21\text{V to } -33\text{V}$	-	9.0	80	mV
			$V_I = -24\text{V to } -30\text{V}$	-	5.0	80	
Load Regulation (Note1)	$\Delta V_O$	$T_J = +25\text{ }^{\circ}\text{C}$	$I_O = 5.0\text{mA to } 500\text{mA}$	-	30	360	mV
Quiescent Current	$I_Q$	$T_J = +25\text{ }^{\circ}\text{C}$	-	3	6	mA	
Quiescent Current Change	$\Delta I_Q$	$I_O = 5\text{mA to } 350\text{mA}$	-	-	0.4	mA	
		$V_I = -21\text{V to } -33\text{V}$	-	-	0.4		
Output Voltage Drift	$\Delta V_O / \Delta T$	$I_O = 5\text{mA}$	-	-1.0	-	mV/ $^{\circ}\text{C}$	
Output Noise Voltage	$V_N$	$f = 10\text{Hz to } 100\text{kHz}$ , $T_A = +25\text{ }^{\circ}\text{C}$	-	110	-	$\mu\text{V}$	
Ripple Rejection	RR	$f = 120\text{Hz}$ , $V_I = -22\text{V to } -32\text{V}$	54	59	-	dB	
Dropout Voltage	$V_D$	$I_O = 500\text{mA}$ , $T_J = +25\text{ }^{\circ}\text{C}$	-	1.1	-	V	
Short Circuit Current	ISC	$V_I = -35\text{V}$ , $T_J = +25\text{ }^{\circ}\text{C}$	-	140	-	mA	
Peak Current	$I_{PK}$	$T_J = +25\text{ }^{\circ}\text{C}$	-	650	-	mA	

### Note;

1. Load and line regulation are specified at constant junction temperature. Change in  $V_O$  due to heating effects must be taken into account separately. Pulse testing with low duty is used.

## Electrical Characteristics (MC79M24)

(Refer to test circuit,  $0\text{ }^{\circ}\text{C} \leq T_J \leq +125\text{ }^{\circ}\text{C}$ ,  $I_O = 350\text{mA}$ ,  $V_I = -33\text{V}$ , unless otherwise specified)

Parameter	Symbol	Conditions	Min.	Typ.	Max.	Unit	
Output Voltage	$V_O$	$T_J = +25\text{ }^{\circ}\text{C}$	- 23	- 24	- 25	V	
		$I_O = 5\text{mA to } 350\text{mA}$ $V_I = -27\text{V to } -38\text{V}$	- 22.8	- 24	- 25.2		
Line Regulation (Note1)	$\Delta V_O$	$T_J = +25\text{ }^{\circ}\text{C}$	$V_I = -27\text{V to } -38\text{V}$	-	9.0	80	mV
			$V_I = -30\text{V to } -36\text{V}$	-	5.0	70	
Load Regulation (Note1)	$\Delta V_O$	$T_J = +25\text{ }^{\circ}\text{C}$	$I_O = 5.0\text{mA to } 500\text{mA}$	-	30	300	mV
Quiescent Current	$I_Q$	$T_J = +25\text{ }^{\circ}\text{C}$	-	3	6	mA	
Quiescent Current Change	$\Delta I_Q$	$I_O = 5\text{mA to } 350\text{mA}$	-	-	0.4	mA	
		$V_I = -27\text{V to } -38\text{V}$	-	-	0.4		
Output Voltage Drift	$\Delta V_O / \Delta T$	$I_O = 5\text{mA}$	-	-1.0	-	mV/ $^{\circ}\text{C}$	
Output Noise Voltage	$V_N$	$f = 10\text{Hz to } 100\text{kHz}, T_A = +25\text{ }^{\circ}\text{C}$	-	180	-	$\mu\text{V}$	
Ripple Rejection	RR	$f = 120\text{Hz}, V_I = -28\text{V to } -38\text{V}$	54	58	-	dB	
Dropout Voltage	$V_D$	$I_O = 500\text{mA}, T_J = +25\text{ }^{\circ}\text{C}$	-	1.1	-	V	
Short Circuit Current	$I_{SC}$	$V_I = -35\text{V}, T_J = +25\text{ }^{\circ}\text{C}$	-	140	-	mA	
Peak Current	$I_{PK}$	$T_J = +25\text{ }^{\circ}\text{C}$	-	650	-	mA	

### Note:

1. Load and line regulation are specified at constant junction temperature. Change in  $V_O$  due to heating effects must be taken into account separately. Pulse testing with low duty is used.



## Typical Applications

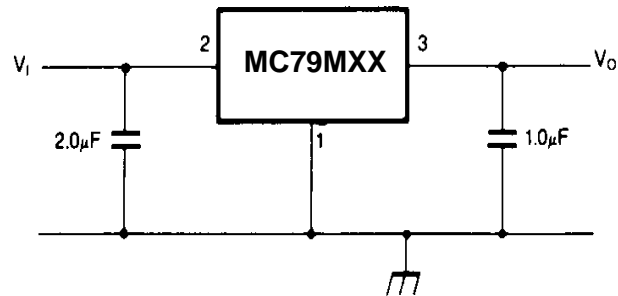

Figure 1. Fixed Output Regulator

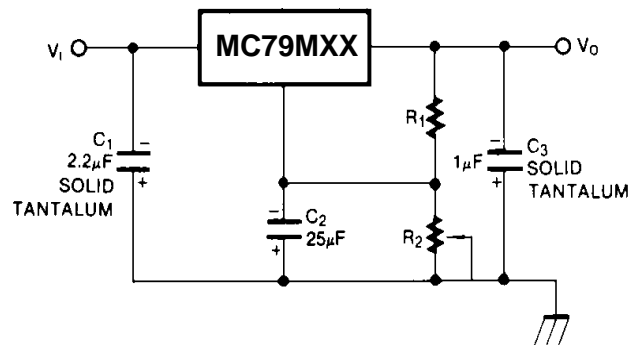

Figure 2. Variable Output

### Notes:

1. Required for stability. For value given, capacitor must be solid tantalum.  $25\mu\text{F}$  aluminum electrolytic may be substituted.
2.  $C_2$  improves transient response and ripple rejection. Do not increase beyond  $50\mu\text{F}$ .

# Mechanical Dimensions

## Package

Dimensions in millimeters

### TO-220

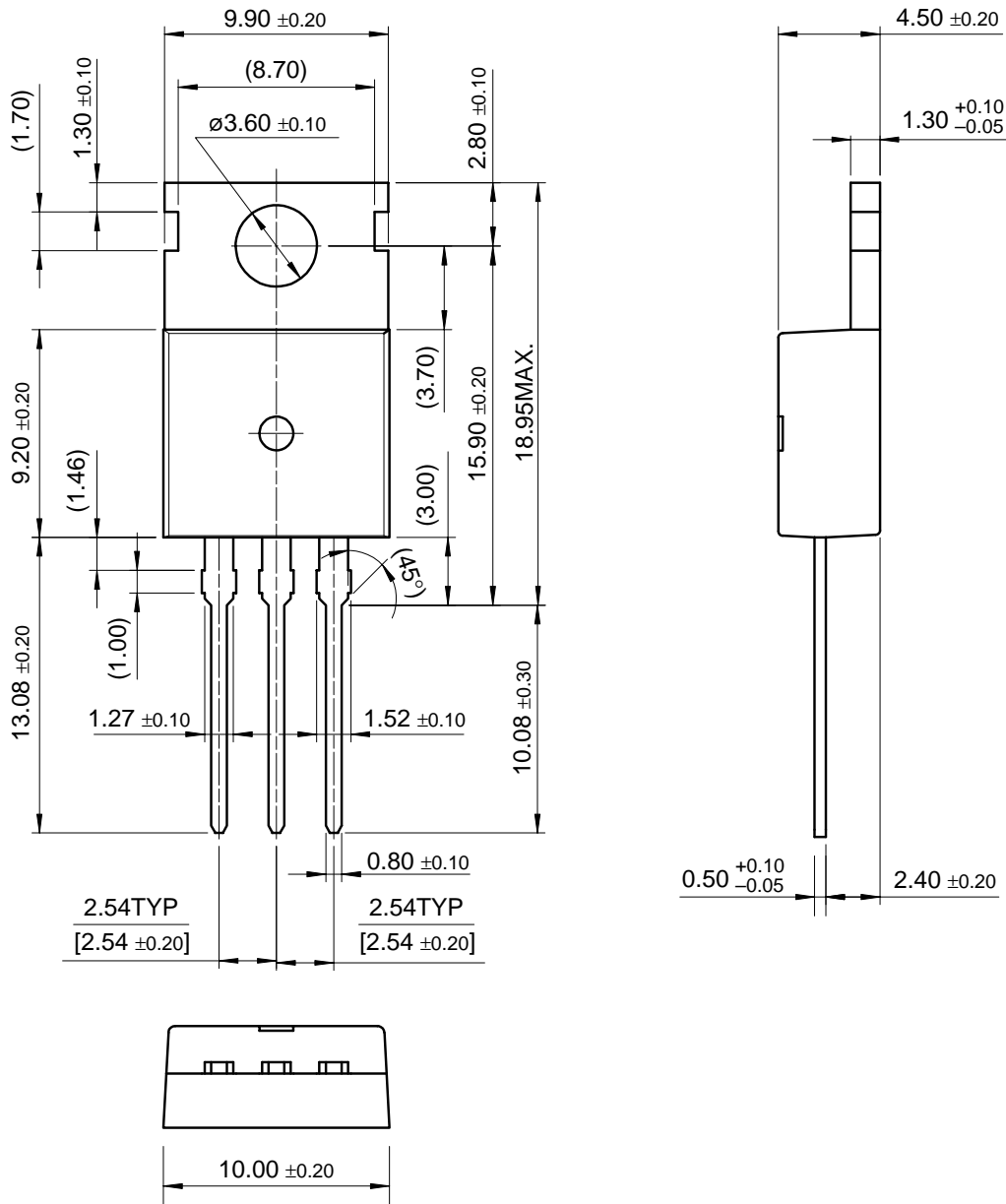

**Mechanical Dimensions** (Continued)

**Package**

Dimensions in millimeters

**D-PAK**

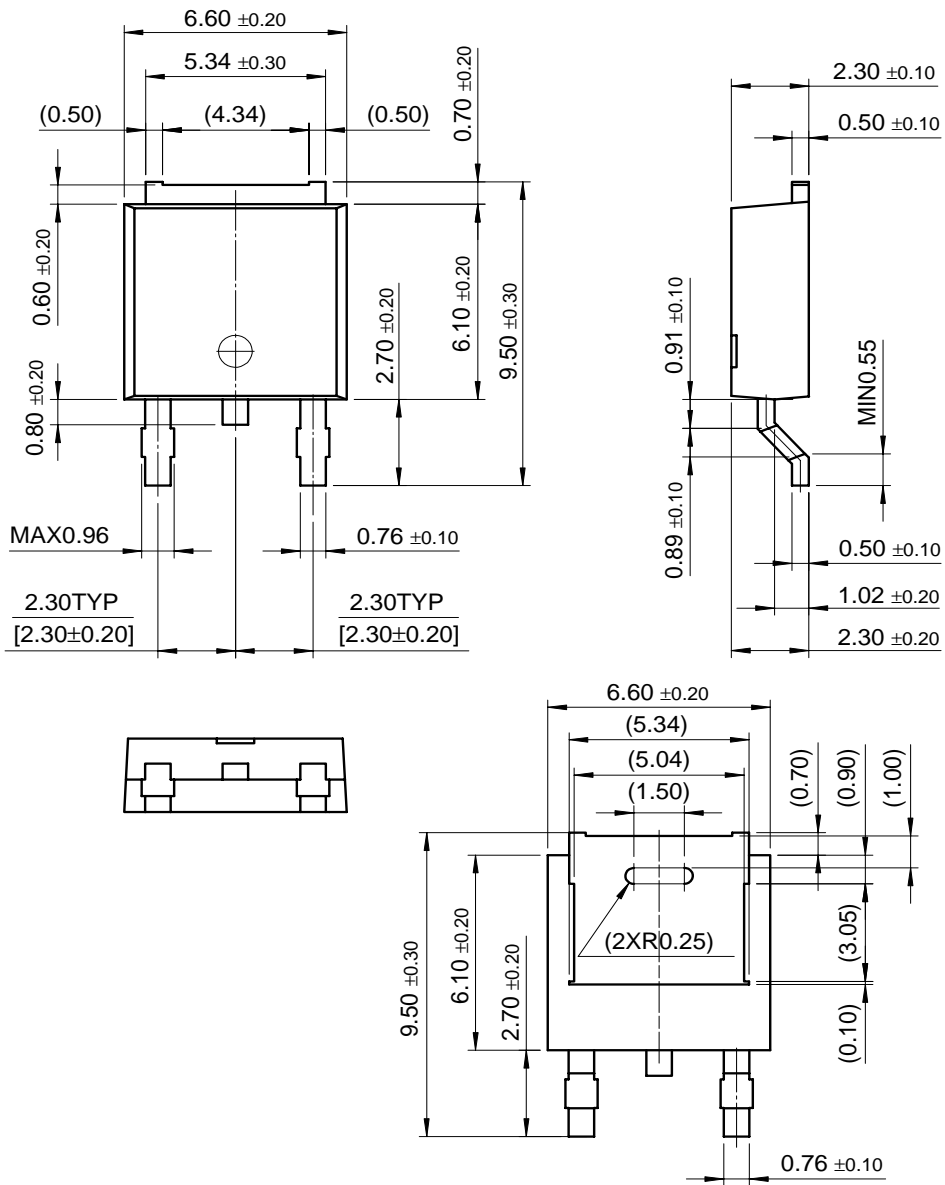

## Ordering Information

Product Number	Package	Operating Temperature
MC79M05CT	TO-220	0 ~ + 125°C
MC79M06CT		
MC79M08CT		
MC79M12CT		
MC79M15CT		
MC79M18CT		
MC79M24CT		



**DISCLAIMER**

FAIRCHILD SEMICONDUCTOR RESERVES THE RIGHT TO MAKE CHANGES WITHOUT FURTHER NOTICE TO ANY PRODUCTS HEREIN TO IMPROVE RELIABILITY, FUNCTION OR DESIGN. FAIRCHILD DOES NOT ASSUME ANY LIABILITY ARISING OUT OF THE APPLICATION OR USE OF ANY PRODUCT OR CIRCUIT DESCRIBED HEREIN; NEITHER DOES IT CONVEY ANY LICENSE UNDER ITS PATENT RIGHTS, NOR THE RIGHTS OF OTHERS.

**LIFE SUPPORT POLICY**

FAIRCHILD'S PRODUCTS ARE NOT AUTHORIZED FOR USE AS CRITICAL COMPONENTS IN LIFE SUPPORT DEVICES OR SYSTEMS WITHOUT THE EXPRESS WRITTEN APPROVAL OF THE PRESIDENT OF FAIRCHILD SEMICONDUCTOR CORPORATION. As used herein:

1. Life support devices or systems are devices or systems which, (a) are intended for surgical implant into the body, or (b) support or sustain life, and (c) whose failure to perform when properly used in accordance with instructions for use provided in the labeling, can be reasonably expected to result in a significant injury of the user.
2. A critical component in any component of a life support device or system whose failure to perform can be reasonably expected to cause the failure of the life support device or system, or to affect its safety or effectiveness.