

# FAN8001D

## 5-Channel Motor Driver

### Features

- 1 phase, full-wave, linear DC motor driver
- Built-in TSD (Thermal shutdown) circuit
- Built-in 5V regulator (With an external PNP TR)
- Built-in mute circuit
- Built-in loading motor speed control circuit
- Wide operating supply voltage range: 6V~13.2V

### Description

The FAN8001D is a monolithic integrated circuit, suitable for 5-ch motor driver which drives focus actuator, tracking actuator, sled motor, spindle motor and loading motor of CD system.



### Target Applications

- Compact disk player (CDP)
- Video compact disk player (VCD)
- Automotive compact disk player (CDP)
- Other compact disk media

### Ordering Information

Device	Package	Operating Temp.
FAN8001BD	28-SSOPH-375	-25°C ~ +75°C
FAN8001BDTF	28-SSOPH-375	-25°C ~ +75°C

## Pin Assignments

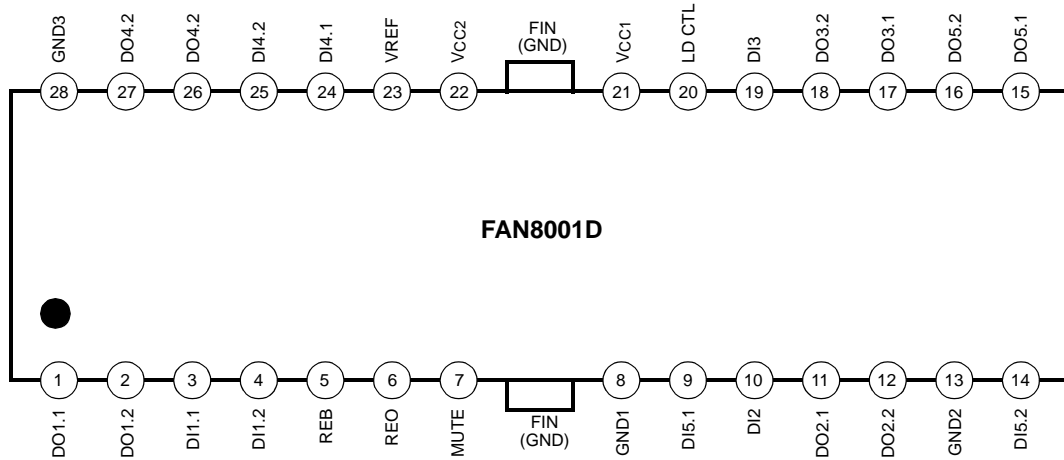

## Pin Definitions

Pin Number	Pin Name	I/O	Pin Function Description
1	DO1.1	O	Focus output 1 (-)
2	DO1.2	O	Focus output 2 (+)
3	DI1.1	I	Focus input 1
4	DI1.2	I	Focus input 2 (Adjustable)
5	REB	O	Regulator base
6	REO	O	Regulator output, 5V
7	MUTE	I	Mute
8	GND1	-	Ground 1
9	DI5.1	I	Loading input 1
10	DI2	I	Spindle input 2
11	DO2.1	O	Spindle output (+)
12	DO2.2	O	Spindle output (-)
13	GND2	-	Ground 2
14	DI5.2	I	Loading input 2
15	DO5.1	O	Loading output 1(+)
16	DO5.2	O	Loading output 2(-)
17	DO3.1	O	Sled output (-)
18	DO3.2	O	Sled output (+)
19	DI3	I	Sled input
20	LD CTL	I	Loading motor speed control
21	VCC1	-	Supply voltage 1
22	VCC2	-	Supply voltage 2
23	VREF	I	2.5V bias
24	DI4.1	I	Tracking input 1 (Adjustable)

### Pin Definitions (Continued)

Pin Number	Pin Name	I/O	Pin Function Description
25	DI4.2	I	Tracking input 2
26	DO4.1	O	Tracking output 1 (+)
27	DO4.2	O	Tracking output 2 (-)
28	GND3	-	Ground 3

### Internal Block Diagram

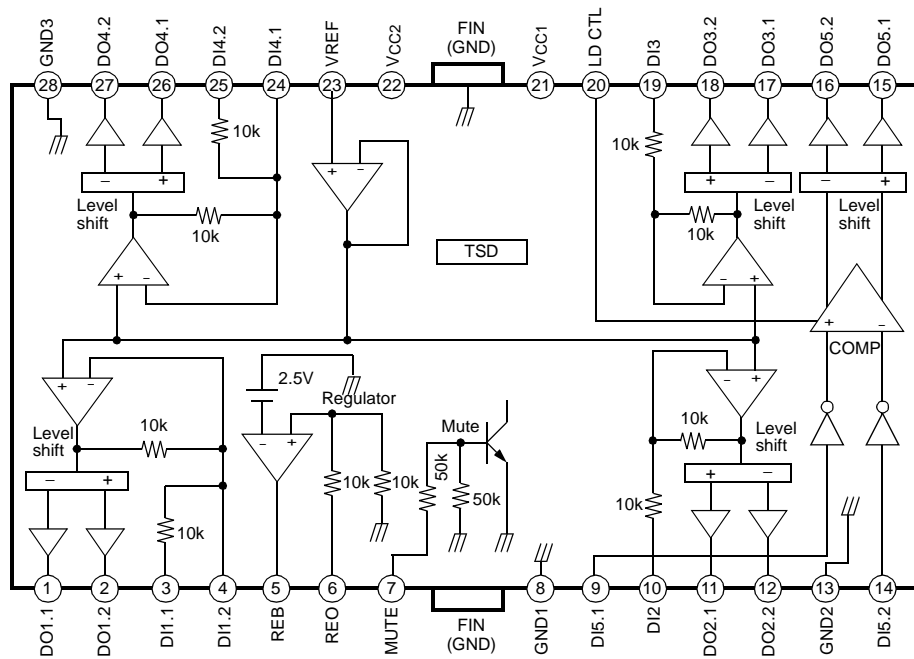

### Equivalent Circuits

Driver input (Except for loading motor driver)	Driver output
Loading motor driver input	Loading motor speed control input
Mute input	Bias input

## Absolute Maximum Ratings (Ta = 25°C)

Parameter	Symbol	Value	Unit
Maximum supply voltage	VCC MAX	18	V
Power dissipation	PD	1.7 <sup>note</sup>	W
Operating temperature	TOPR	-25 ~ +75	°C
Storage temperature	TSTG	-55 ~ +150	°C
Maximum current output	IOMAX	1	A

### NOTE:

1. When mounted on 76mm × 114mm × 1.57mm PCB (Phenolic resin material).
2. Power dissipation reduces 13.6mW / °C for using above Ta=25°C
3. Do not exceed Pd and SOA (Safe Operating Area).

## Power Dissipation Curve

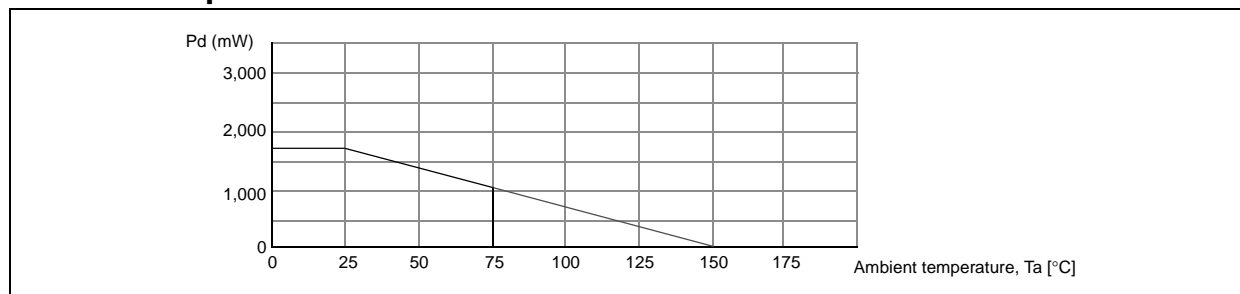

## Recommended Operating Condition (Ta = 25°C)

Parameter	Symbol	Value	Unit
Operating supply voltage	VCC	6 ~ 13.2	V

## Electrical Characteristics

( $T_a=25^{\circ}\text{C}$ ,  $V_{CC}=8\text{V}$ ,  $R_L=8\Omega$ ,  $f=1\text{kHz}$ , unless otherwise specified)

Parameter	Symbol	Conditions	Min.	Typ.	Max.	Units
Quiescent circuit current	ICCQ	Under no-load	2.5	6	10	mA
Mute-on current	IMUTE	Pin 7=GND	-	2.5	5	mA
Mute-on voltage	VMON	-	-	-	0.5	V
Mute-off voltage	VMOFF	-	2	-	-	V
<b>REGULATOR PART</b>						
Output voltage	VREG	$I_L=100\text{mA}$	4.7	5.0	5.3	V
Load regulation	$\Delta V_{RL3}$	$I_L=0\rightarrow 200\text{mA}$	-50	0	50	mV
Line regulation	$\Delta V_{CC}$	$V_{CC}=6\rightarrow 13\text{V}$ , $I_L=100\text{mA}$	-20	0	80	mV
<b>DRIVER PART (Except for loading motor driver)</b>						
Input offset voltage	$V_{IO}$	-	-15	-	15	mV
Output offset voltage 1	$V_{OO1}$	-	-40	-	40	mV
Maximum source current 1	ISOURCE1	$R_L=8\Omega\rightarrow V_{CC}$	0.25	0.4	-	A
Maximum sink current 1	ISINK1	$R_L=8\Omega\rightarrow \text{GND}$	0.25	0.4	-	A
Maximum output voltage 1	VOM1	$V_{IN}=0.7\text{V}$	2.5	3.3	-	V
Maximum output voltage 2	VOM2	$V_{IN}=7\text{V}$	-	-4.5	-3.7	V
Closed-loop voltage gain	$A_{VF}$	$V_{IN}=0.1V_{RMS}$	10	12	14	dB
Ripple rejection ratio	RR	$V_{IN}=0.1V_{RMS}$ , $f=120\text{Hz}$	40	60	-	dB
Slew rate	SR	120Hz, $V_{IN}=1V_{RMS}$ , Square wave	1	2	-	V / $\mu\text{s}$
<b>LOADING MOTOR DRIVER PART (Unless otherwise specified, VCTL=opened)</b>						
Output voltage 1	VO1	$V_{PIN9}=5\text{V}$ , $V_{PIN14}=0\text{V}$ , $R_L=45\Omega$	2.5	3.1	3.8	V
Output voltage 2	VO2	$V_{PIN9}=0\text{V}$ , $V_{PIN14}=5\text{V}$ , $R_L=45\Omega$	2.5	3.1	3.8	V
Output voltage regulation 1 (CTL)	VOCTL1	$V_{CTL}=3.5\rightarrow 4.5\text{V}$ , $V_{PIN9}=5\text{V}$ , $V_{PIN14}=0\text{V}$ , $R_L=45\Omega$	0.5	1.0	1.5	V
Output voltage regulation 2 (CTL)	VOCTL2	$V_{CTL}=3.5\rightarrow 4.5\text{V}$ , $V_{PIN9}=0\text{V}$ , $V_{PIN14}=5\text{V}$ , $R_L=45\Omega$	0.5	1.0	1.5	V
Load regulation 1	$\Delta V_{RL1}$	$I_L=100\rightarrow 400\text{mA}$ , $V_{PIN9}=5\text{V}$ , $V_{PIN14}=0\text{V}$	-	300	700	mV
Load regulation 2	$\Delta V_{RL2}$	$I_L=100\rightarrow 400\text{mA}$ , $V_{PIN9}=0\text{V}$ , $V_{PIN14}=5\text{V}$	-	300	700	mV
Output offset voltage 2	VOO2	$V_{PIN9}=5\text{V}$ , $V_{PIN14}=5\text{V}$	-40	-	40	mV
Output offset voltage 3	VOO3	$V_{PIN9}=0\text{V}$ , $V_{PIN14}=0\text{V}$	-40	-	40	mV

## Application Information

### 1. MUTE

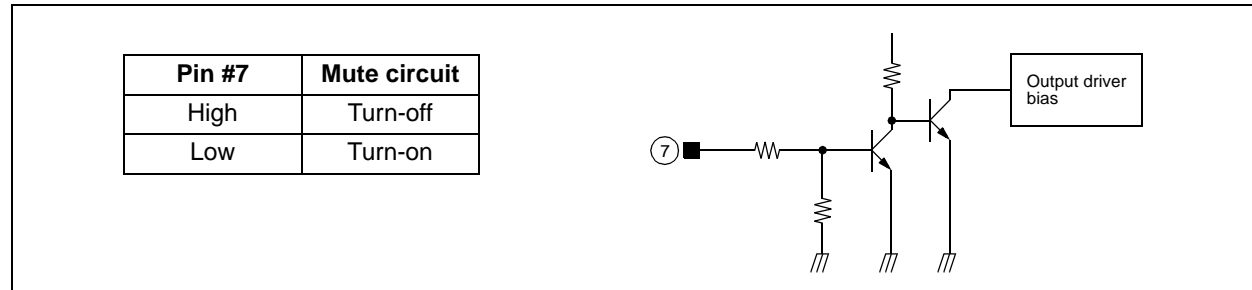

- When the mute pin #7 is open or the voltage of the mute pin #7 is below 0.5V, the mute circuit is activated so that the output circuit will be muted.
- When the voltage of the mute pin is above 2V, the mute circuit is stopped and the output circuit is operated normally.
- If the chip temperature rises above 175°C, then the TSD (Thermal shutdown) circuit is activated and the output circuit is muted.

### 2. TSD (THERMAL SHUTDOWN)

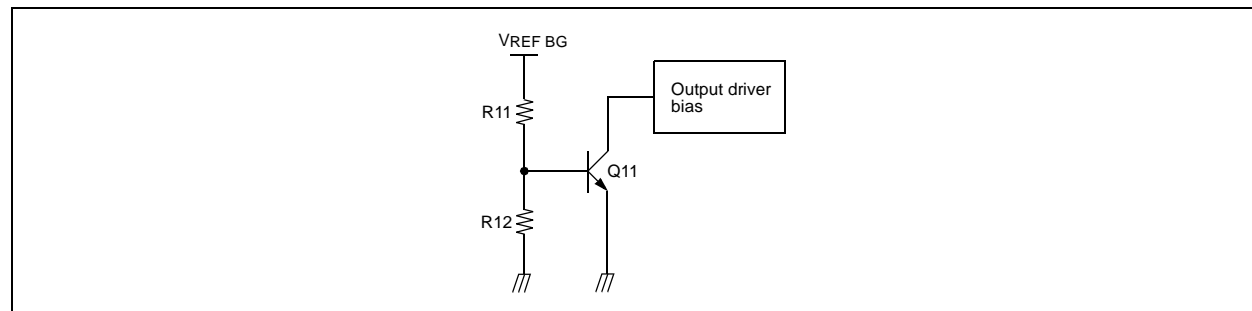

- The  $V_{REF\ BG}$  is the output voltage of the band-gap-referenced biasing circuit and acts as the input voltage of the TSD circuit.
- The base-emitter voltage of the TR, Q11 is designed to turn-on at below voltage.  

$$V_{BE} = V_{REF\ BG} \times R12 / (R11+R12) = 400mV$$
- When the chip temperature rises up to 175°C, then the turn-on voltage of the Q11 would drop down to 400mV. Hence, the Q11 would turn on so the output circuit will be muted.

### 3. REGULATOR

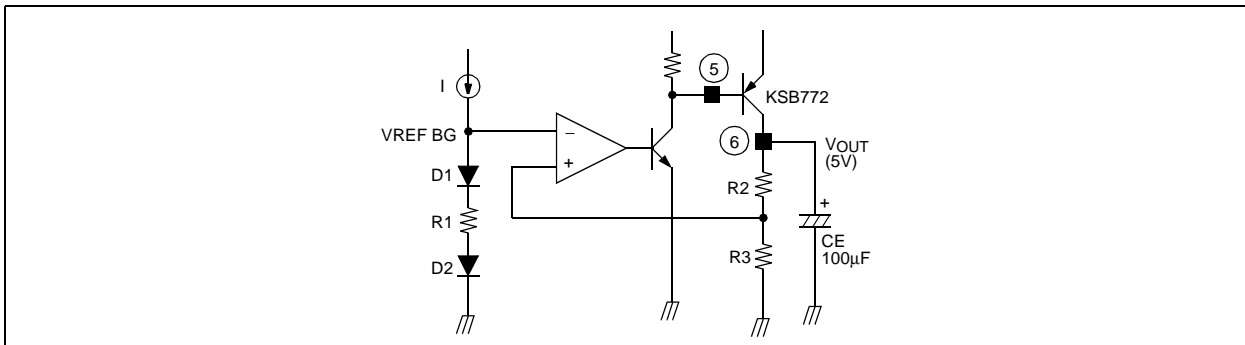

- The  $V_{REF\ BG}$  is the output voltage of the band-gap-referenced biasing circuit and is the reference voltage of the regulator.
- The external circuit is composed of the transistor, KSB772 and a capacitor,  $100\mu\text{F}$ , and the capacitor is used as a ripple filter and should have a good temperature characteristics.
- The output voltage,  $V_{OUT}$  is determined as follows.  

$$V_{OUT} = V_{REF\ BG} \times 2 = 2.5 \times 2 = 5\text{V} \quad (R2 = R3)$$

$$R2 = R3$$

### 4. LOADING MOTOR DRIVER

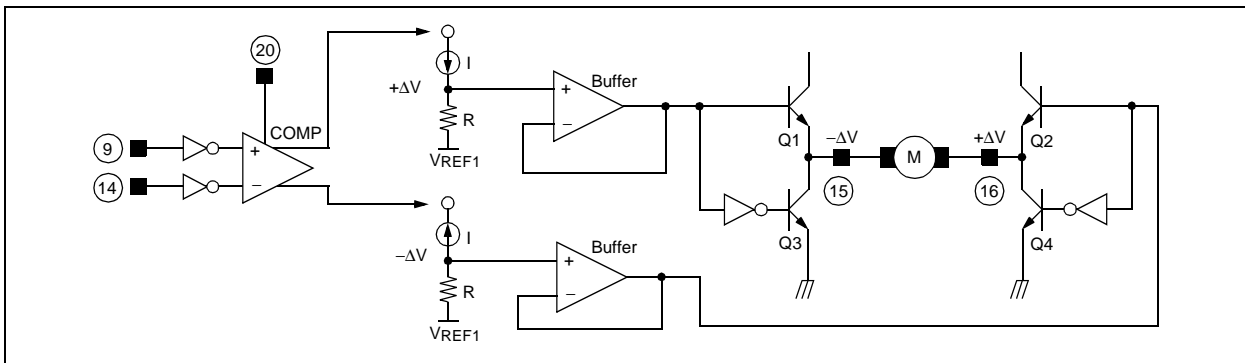

- The input voltages of (5V and 0V) or (0V and 5V) pairs are applied to the input pin #9 and #14 respectively.
- When the input voltages are applied to the input pin #9 and #14, then the output of the comparator is decided depends on the input voltage status.
- As shown in the above diagram, the difference  $\Delta V$ ,  $[V_{REF1} + (I \times R)] - [V_{REF1} - (I \times R)]$ , is applied to the both terminals of the motor. The direction of the motor is decided by the voltage difference,  $+\Delta V$  and  $-\Delta V$ .
- The output characteristics is as follows,
  - If pin # 9=5V and #14=0V, then pin # 15=+ $\Delta V$  and #16=  $-\Delta V$ , hence the motor turn in forward direction.
  - If pin # 9=0V and #14=5V, then pin # 15=  $-\Delta V$  and #16=+ $\Delta V$ , hence the motor turn in reverse direction.
  - If pin # 9=5V and #14=5V, then  $\Delta V=0\text{V}$ , hence the motor stop.
  - If pin # 9=0V and #14=0V, then  $\Delta V=0\text{V}$ , hence the motor stop.
- When the rotation speed control of the loading motor is desired, refer to the follows.



## 5. LOADING MOTOR SPEED CONTROL

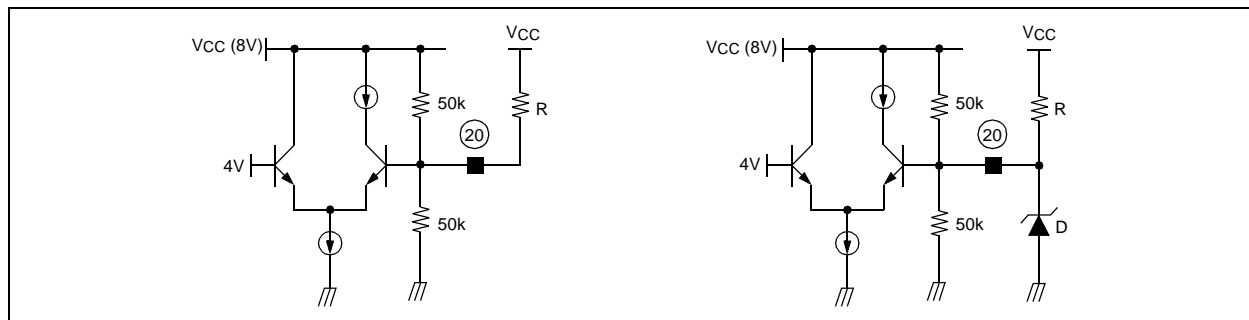

- If the torque of the loading motor is too low with the pin #20 open, then use it as the above diagram.
- The desired torque could be obtained by selecting the appropriate resistor R as shown in the left diagram.
- If it is necessary, the zener diode can be used as in the right diagram.
- The maximum torque is obtained when the applied voltage at pin #20 is about 6.8V (at  $V_{CC}=8V$ ).

## 6. DRIVER (EXCEPT FOR LOADING MOTOR DRIVER)

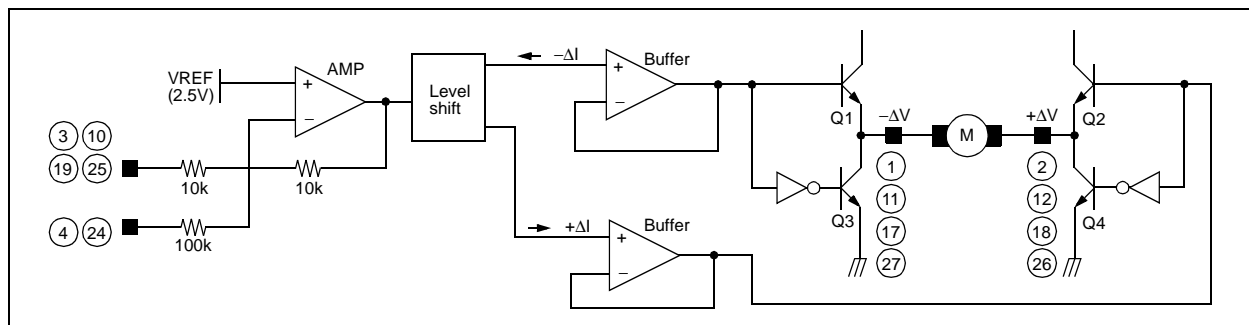

- The voltage,  $V_{REF}$ , is the reference voltage given by the bias voltage of the pin #23.
- The input signal through the pin #3 is amplified by 10k/10k times and then fed to the level shift.
- The level shift produces the current due to the difference between the input signal and the arbitrary reference signal. The current produced as  $+\Delta I$  and  $-\Delta I$  is fed into the driver buffer.
- Driver Buffer operates the power TR of the output stage according to the state of the input signal.
- The output stage is the BTL Driver and the motor is rotating in forward direction by operating TR Q1 and TR Q4. On the other hand, if TR Q2 and TR Q3 is operating, the motor is rotating in reverse direction.
- When the input voltage through the pin #3 is below the  $V_{REF}$ , the motor rotates forward direction.
- When the input voltage through the pin #3 is above the  $V_{REF}$ , the motor rotates reverse direction.
- If it is desired to change the gain, then the pin #4 or #24 can be used.

7. When the bias voltage of the pin #23 is below 1.4V, then the output circuit will be muted.  
Hence for the normal operation, the bias voltage should be used in 1.6V~6.5V.

8. Connect a by-pass capacitor, 0.1 $\mu$ F between the supply voltage source.

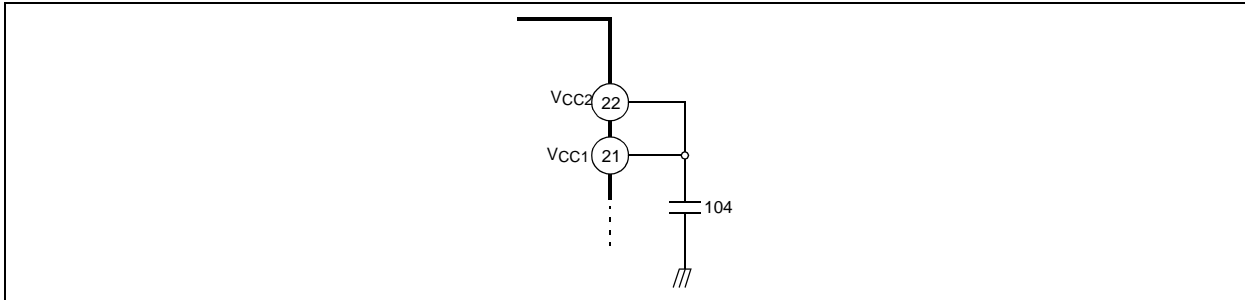

9. Radiation fin is connecting to the internal GND of the package.  
Connect the fin to the external GND.

Typical Performance Characteristics

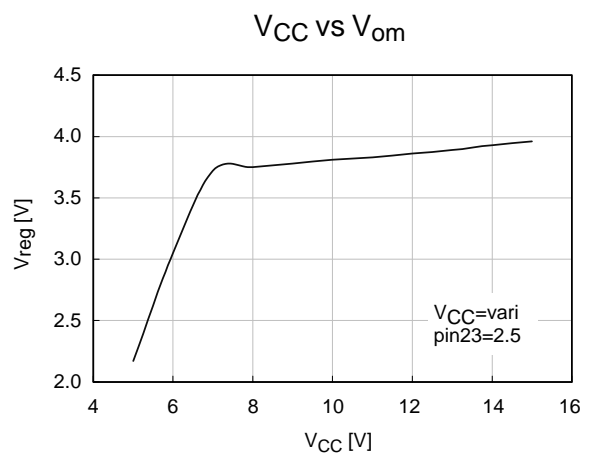
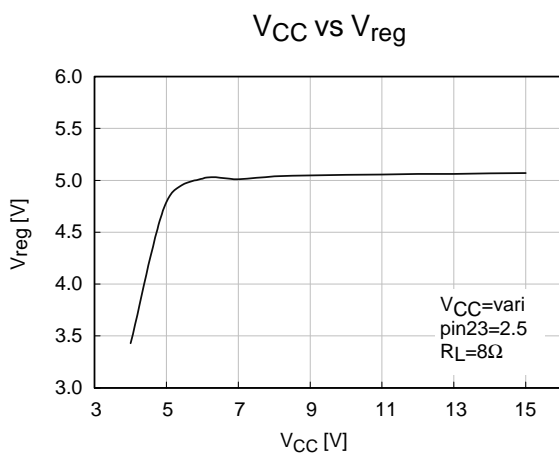
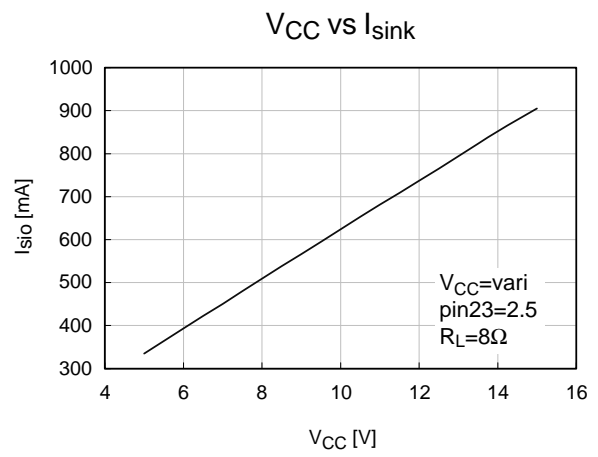
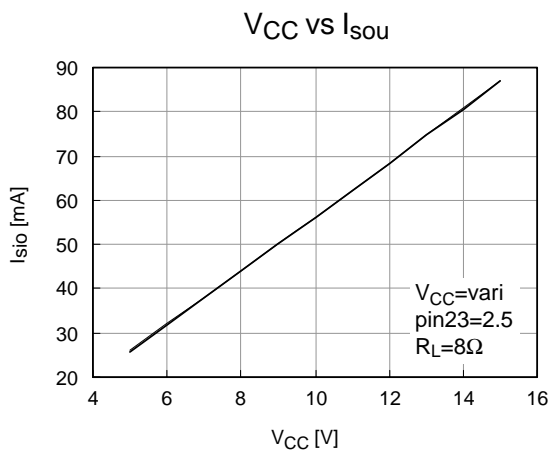
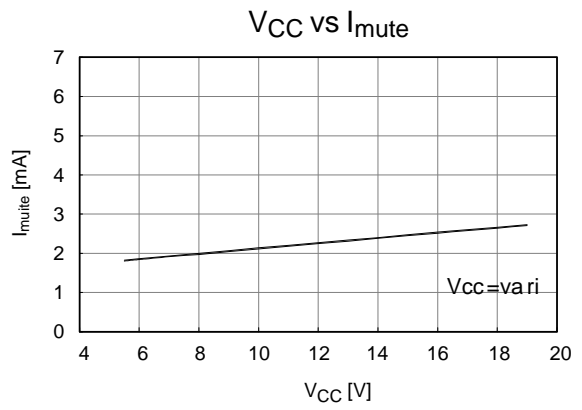
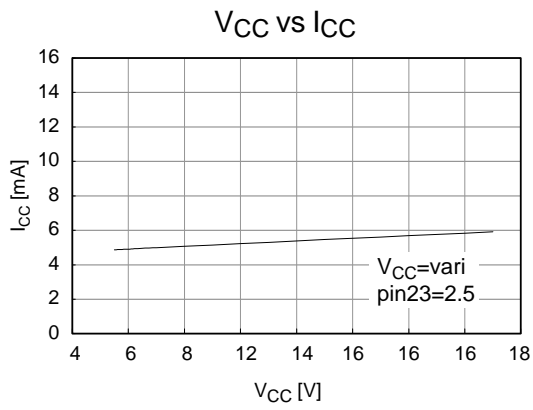

# Test Circuits

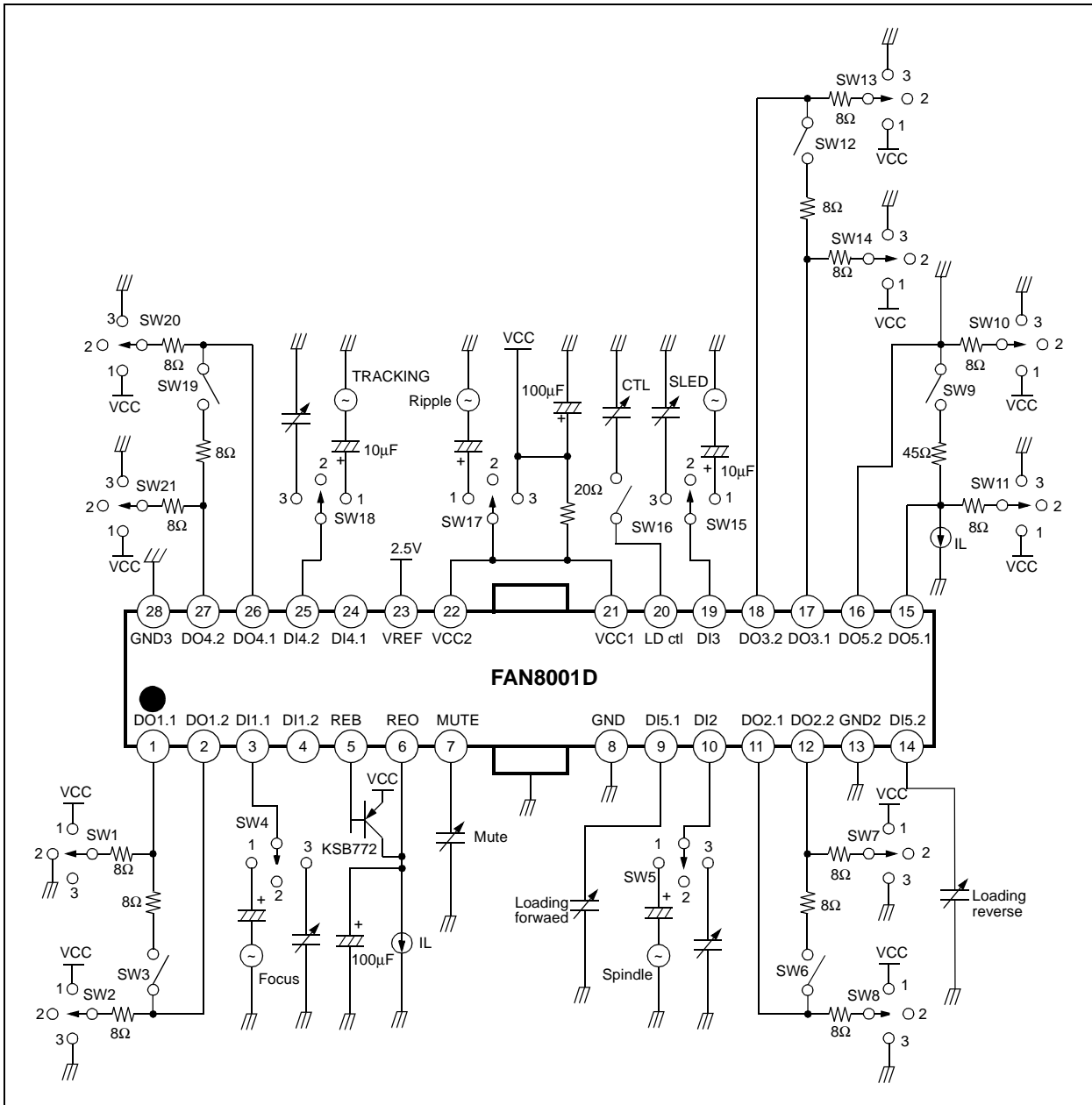

## Application Circuits

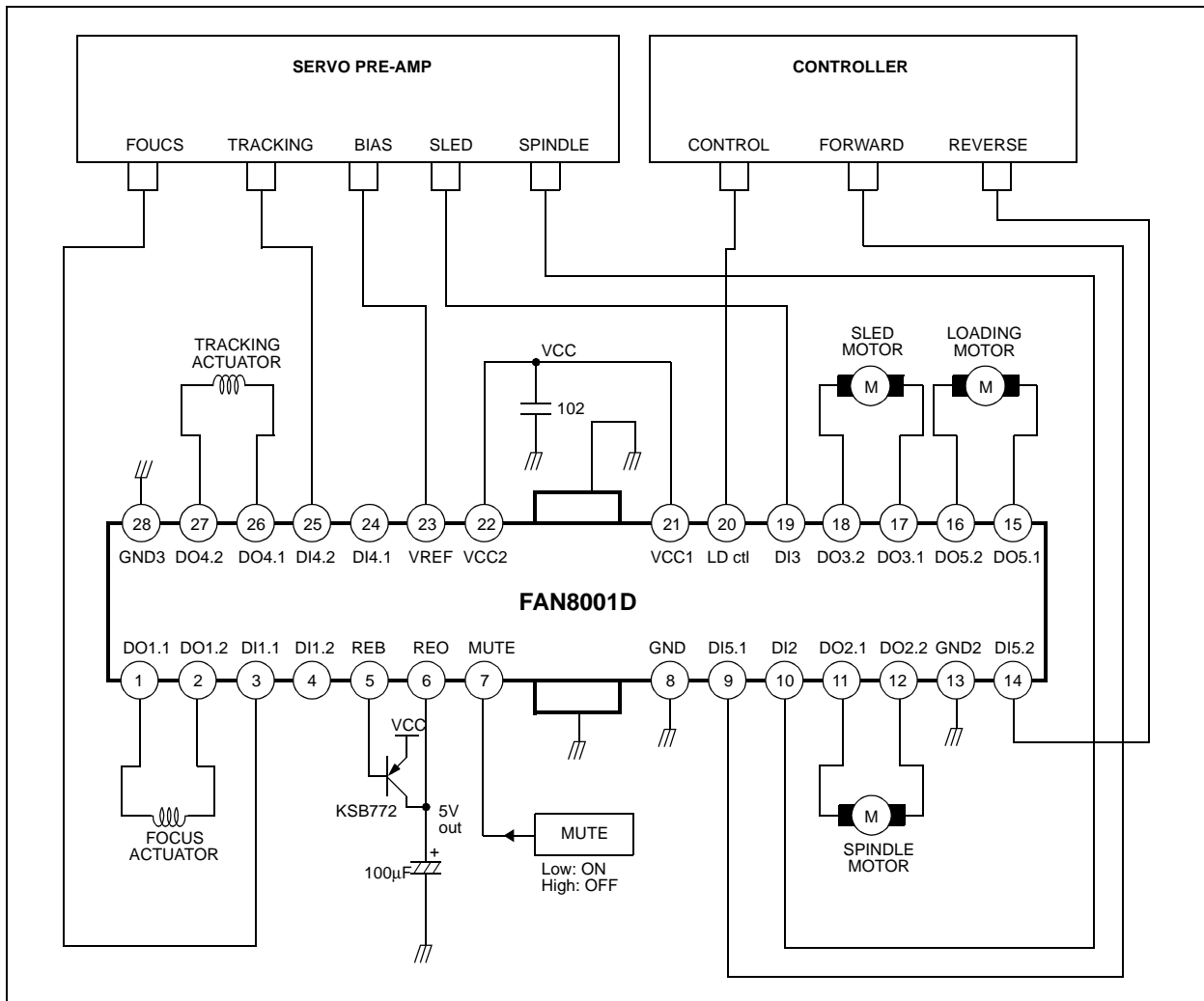

**DISCLAIMER**

FAIRCHILD SEMICONDUCTOR RESERVES THE RIGHT TO MAKE CHANGES WITHOUT FURTHER NOTICE TO ANY PRODUCTS HEREIN TO IMPROVE RELIABILITY, FUNCTION OR DESIGN. FAIRCHILD DOES NOT ASSUME ANY LIABILITY ARISING OUT OF THE APPLICATION OR USE OF ANY PRODUCT OR CIRCUIT DESCRIBED HEREIN; NEITHER DOES IT CONVEY ANY LICENSE UNDER ITS PATENT RIGHTS, NOR THE RIGHTS OF OTHERS.

**LIFE SUPPORT POLICY**

FAIRCHILD'S PRODUCTS ARE NOT AUTHORIZED FOR USE AS CRITICAL COMPONENTS IN LIFE SUPPORT DEVICES OR SYSTEMS WITHOUT THE EXPRESS WRITTEN APPROVAL OF THE PRESIDENT OF FAIRCHILD SEMICONDUCTOR INTERNATIONAL. As used herein:

1. Life support devices or systems are devices or systems which, (a) are intended for surgical implant into the body, or (b) support or sustain life, and (c) whose failure to perform when properly used in accordance with instructions for use provided in the labeling, can be reasonably expected to result in a significant injury of the user.
2. A critical component in any component of a life support device or system whose failure to perform can be reasonably expected to cause the failure of the life support device or system, or to affect its safety or effectiveness.