

**FEATURES**

- designed to drive Class D integrated receivers
- adjustable peak clipper
- low current drain
- low noise and distortion
- low external parts count
- two low noise preamplifiers
- transconductance output stage
- mid supply referenced output
- preamp A for Gain Trim or Telecoil

**STANDARD PACKAGING**

- 10 pin MICropac
- 10 pin PLID®
- 10 pin SLT
- Chip ( 56 x 84 mils)  
Au Bump

**DESCRIPTION**

The GK504 is Gennum's proprietary low current preamplifier designed to drive the Class D series receivers. It consists of two independent single-ended, low noise inverting amplifiers, a symmetrical peak clipping, mid-supply referenced, transconductance output stage, and an on-chip microphone decoupling resistor.

Blocks A and B typically have an open loop voltage gain of 53 dB, with the closed loop gain set by the ratio of the feedback resistor to source impedance. It is recommended that the maximum closed loop gain be 20 dB lower than the open loop gain. All blocks of the device are internally bias compensated preventing any DC current flow via external feedback resistors. Without this compensation, audible scratchiness would be present during changes in Volume Control settings. It is acceptable to DC-couple blocks A and B of the device, however the third stage must be AC coupled in order to maintain DC bias requirements.

The major advantage of the GK504 over other preamplifiers is the electronic MPO adjustment. Since conventional MPO is not possible in the class D receivers, it is provided electronically. The maximum output swing is easily set using an  $R_{MPO}$  resistor. The receiver output level is thus limited, preventing it from exceeding the discomfort level.

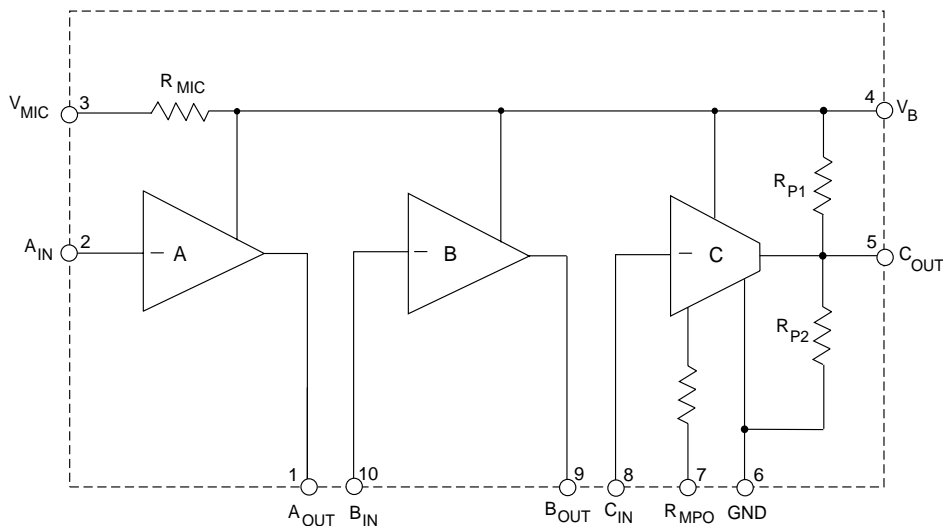

U.S. Patent No.07/354,327

**BLOCK DIAGRAM**

## ABSOLUTE MAXIMUM RATINGS

Parameter	Value / Units
Supply Voltage	5 VDC
Power Dissipation	25 mW
Operating Temperature	-10°C to + 40°C
Storage Temperature	-20°C to + 70°C

**CAUTION**  
CLASS 1 ESD SENSITIVITY



## PIN CONNECTIONS

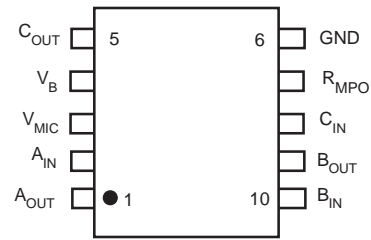

## ELECTRICAL CHARACTERISTICS

Positive Current corresponds to current INTO the pin, Negative Current corresponds to current OUT of the pin, Conditions: Frequency = 1 kHz, Temperature 25°C.  $V_p$  - Pin voltage measured with conditions as shown in Test Circuit.

PARAMETER	SYMBOL	CONDITIONS	MIN	TYP	MAX	UNITS
Supply Current	$I_{AMP}$		165	240	315	$\mu A$
Input Referred Noise	IRN	NFB 0.2 – 10 kHz at 12 dB/oct	-	2	-	$\mu VRMS$
Distortion	THD		-	<1.0	-	%
On-Chip Microphone Resistance	$R_{MIC}$		3	4	5	$k\Omega$
STAGES A and B						
Input Bias Current	$I_{BIAS}$	$R_F=1M$ (Note 1)	-25	0	25	nA
Input Bias Voltage	$V_{BIAS}$		500	590	650	mV
Output Swing Lo	$V_{OL}$	$R_F=1M$ (Note 2)	200	280	590	mV
Max Output Current Capability	$I_{MAX}$		-15	-30	-45	$\mu A$
Open Loop Voltage Gain	$A_{VOL}$		46	53	-	dB
OUTPUT STAGE						
Voltage Gain (Pin 8 to Pin 5)	$A_V$	$V_{IN,AC} = -52$ dBV, $R_{MPO} = 0\Omega$	14	16	18	dB
Gain Loss (Pin 8 to Pin 5)	$\Delta GAIN$	$V_{IN} = -62$ dBV, $R_{MPO} = 50k$ , Note 3	-	0	2.5	dB
Maximum Output Level	MPO	$V_{IN,AC} = -22$ dBV, $R_{MPO} = 0\Omega$	-14.5	-12.5	-10.5	dBV
MPO Range	$\Delta MPO$	$V_{IN,AC} = -22$ dBV, $R_{MPO} = (0$ to 10k)	12	14	16	dB
Output Impedance	$Z_{OUT}$		19	24	29	$K\Omega$

All parameters and conditions remain as shown in Test Circuit unless otherwise specified in Conditions column.

**NOTES:** 1.  $I_{BIAS} = (V_p(1,9) - V_p(1,9)_{[RF=1M]})/1M$

2.  $V_{OL} = V_{BIAS} - V_p(1,9)_{[VIN DC = +1\mu A, RF=1M, IL = +15\mu A]}$

3.  $\Delta GAIN = (V_{OUT} / V_{IN} [VIN = -62dBV, RMPO=0]) - (V_{OUT} / V_{IN} [VIN = -62dBV, RMPO=50k])$

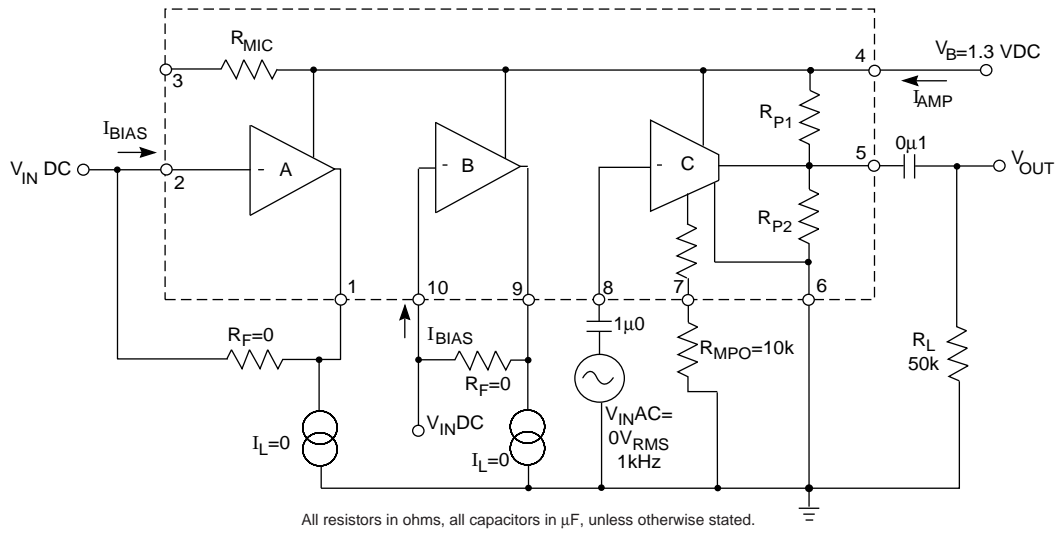

Fig. 1 Test Circuit

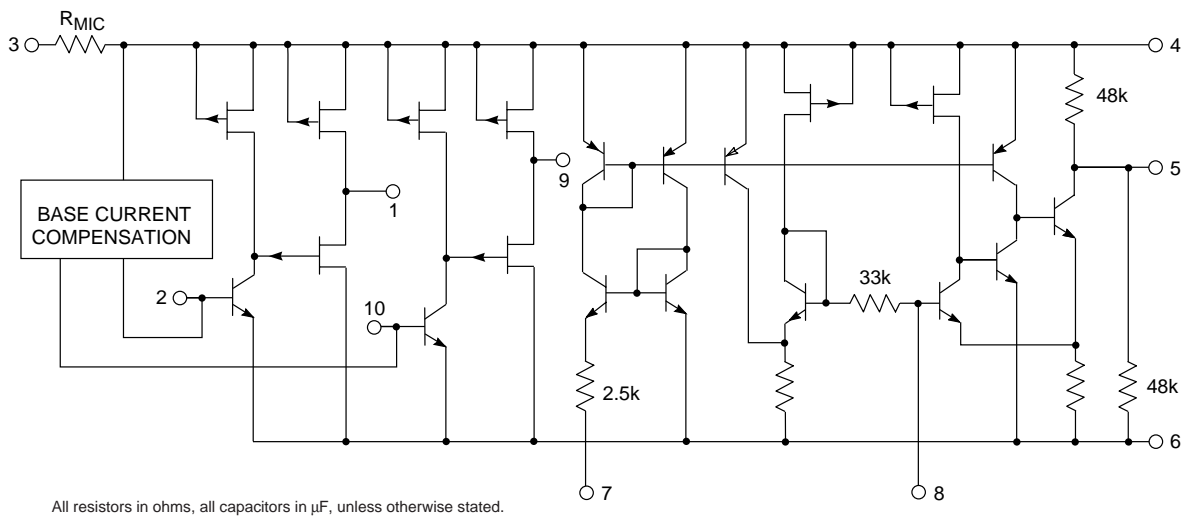
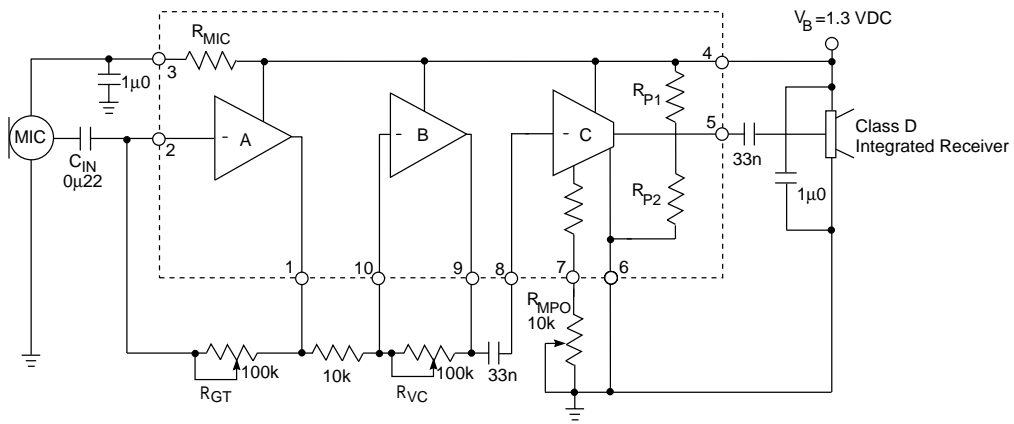
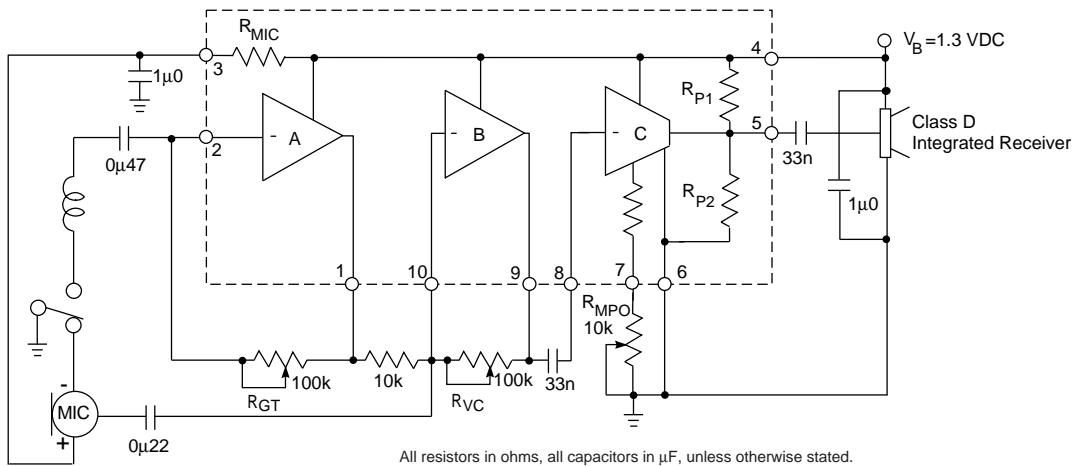

Fig. 2 Functional Schematic



All resistors in ohms, all capacitors in  $\mu\text{F}$ , unless otherwise stated.

Fig. 3 Typical Hearing Instrument Application



All resistors in ohms, all capacitors in  $\mu\text{F}$ , unless otherwise stated.

Fig. 4 Typical Hearing Instrument Application



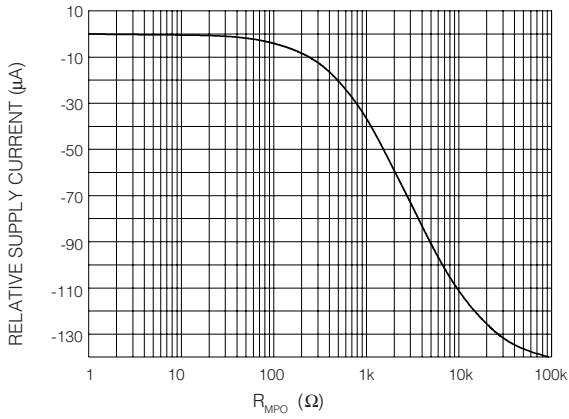

Fig. 10 Change in Supply Current vs  $R_{MPO}$

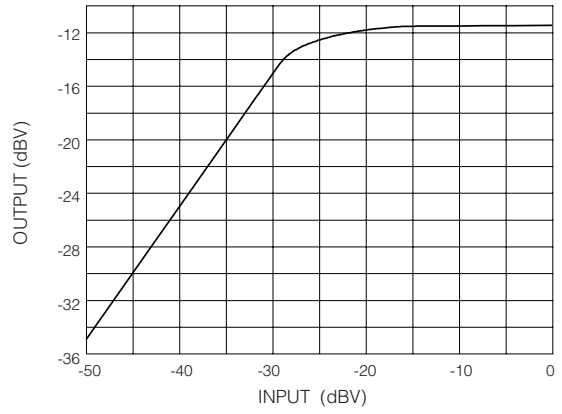

Fig. 11 I/O for Amplifier C (as in Fig. 1)

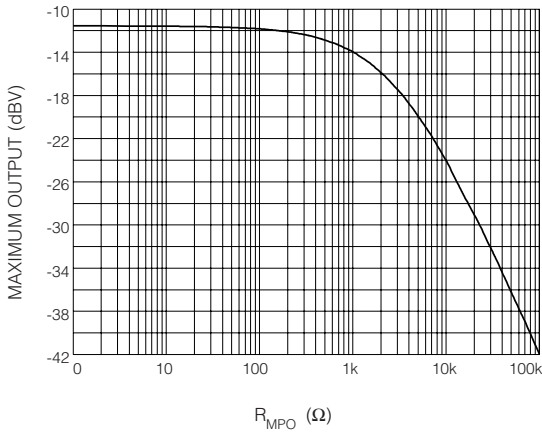

Fig. 12 Maximum Output vs  $R_{MPO}$  (as in Fig. 1,  $V_{IN,AC} = -15dBV$ )

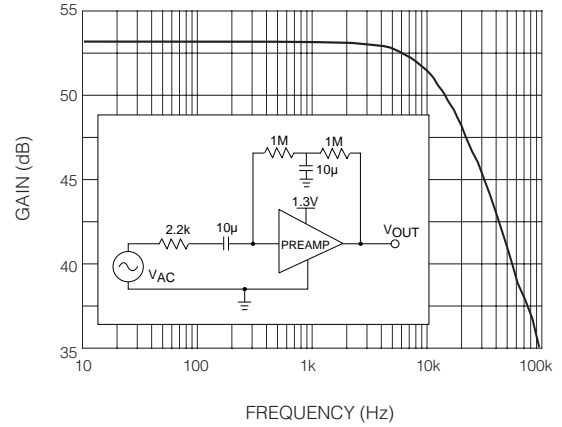

Fig. 13 Preamp A and B Open Loop Voltage Gain

**DOCUMENT IDENTIFICATION: DATA SHEET**  
 The product is in production. Gennum reserves the right to make changes at any time to improve reliability, function or design, in order to provide the best product possible.

**REVISION NOTES:**  
 Updated to Data sheet