

FEATURES

- **unity gain 12 dB/oct. highpass Butterworth filter**
- **adaptive frequency range from 200 Hz to 2 kHz**
- **rectifier threshold set to 82 dB SPL (adjustable)**
- **low noise, typically 2.6 μ V**
- **300 μ A typical current drain**
- **operates from 1.1 to 3 VDC**
- **preamplifier with 56 dB open loop gain**

PACKAGING

- 10 pin MICROpac
- 10 pin PLID[®]
- Chip (73 x 59 mils)

DESCRIPTION

The GR581 is a level-sensitive, adaptive highpass filter comprised of a current controlled highpass filter, a half-wave rectifier, a voltage regulator for microphone bias and a separate preamplifier.

The internal rectifier senses the long term average signal level and controls the filter response by setting the control current of the filter. The rectifier sensitivity, with respect to the input signal, can be increased by placing the internal preamplifier (A) before the filter section of the GR581. The preamplifier has an internal 265 k Ω feedback resistor from its input to output, to facilitate in setting the gain.

An increase of 20 dB above the rectifier threshold will automatically increase the corner frequency one decade above the initial corner frequency. The filter will only allow an increase in corner frequency of one decade, regardless of further increases in the input signal level.

It is recommended that the attack and release times be set to 30 ms and 90 ms respectively. The average time period of a speech frame is about 15 ms which is not long enough to activate the filter, however long term average noise, which can have time periods greater than 30 ms, will activate the filter (providing that the amplitude is above the rectifier threshold).

The GR581 is an improved version of the LS581 adaptive high pass filter and has an identical pinout.

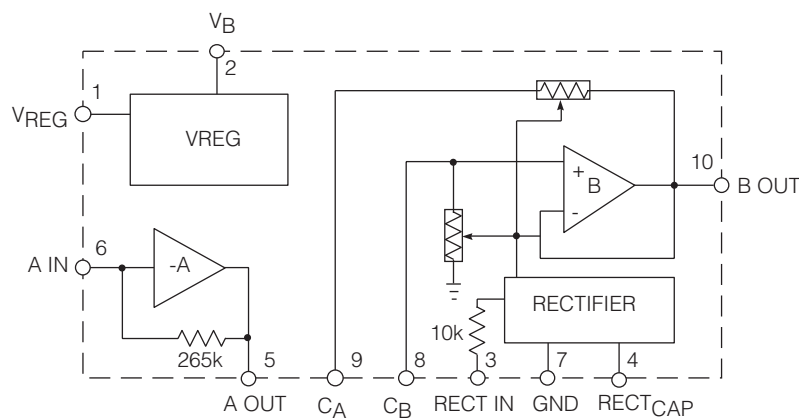

All resistors in ohms, all capacitors in farads unless otherwise stated.

FUNCTIONAL BLOCK DIAGRAM

ABSOLUTE MAXIMUM RATINGS

PARAMETER	VALUE
Supply Voltage	3 VDC
Power Dissipation	25 mW
Operating Temperature Range	-10°C to 40°C
Storage Temperature Range	-20°C to 70°C

CAUTION
CLASS 1 ESD SENSITIVITY

PIN CONNECTIONS

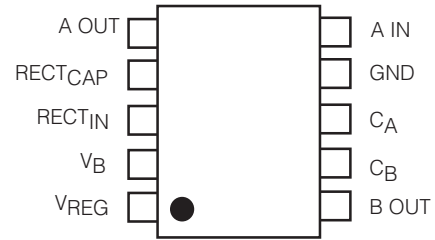

ELECTRICAL CHARACTERISTICS

Conditions: Supply Voltage $V_{CC} = 1.3\text{ V}$, Temperature 25°C

PARAMETER	SYMBOL	CONDITIONS	MIN	TYP	MAX	UNITS
Total Current	I_T		165	300	450	μA
Voltage Regulator (Pin 1)	V_{REG}		0.87	0.93	0.99	V_{DC}
Input Referred Noise	I_{RN}	NFB 0.2 - 10kHz		2.6	-	μVRMS
		Filter f_c set to 0.2kHz at 12dB/oct		5.6	-	
Attack Time	t_{ATT}		-	30	-	ms
Release Time	t_{REL}		-	90	-	ms
STAGE A						
Quiescent Voltage on pin 5	V_{Q5}		0.49	-	0.67	V_{DC}
Open Loop Gain	A_{OL}		45	56	-	dB
Feedback Resistor	R_F		175	265	355	$k\Omega$
Current Sourcing Capacity	I_{SOURCE}		15	30	-	μA
Current Sinking Capacity	I_{SINK}		15	30	-	μA
FILTER SECTION						
Quiescent Voltage on pin 3	V_{Q3}		0.49	0.58	0.67	V_{DC}
Quiescent Voltage on pin 4	V_{Q4}		0.49	0.58	0.67	V_{DC}
Quiescent Voltage on pin 8	V_{Q8}		0.55	-	0.78	V_{DC}
Quiescent Voltage on pin 9	V_{Q9}		0.55	-	0.78	V_{DC}
Filter Insertion Loss	FIL	$V_{OUT} = 850\text{mVRMS}$ $f = 2\text{kHz}$ (S1 closed)	-0.5	0.1	1.3	dB
Distortion	THD	$V_{OUT} = 850\text{mVRMS}$ $f = 1\text{kHz}$ (S1 closed)	-	2	3	%
Rectifier Gain	A_{REC}	$V_{AC2} = 2.5\text{mVRMS}$ (S2 closed) $f = 100\text{Hz}$ (Note 1)	5	7	9	
Rectifier Bandwidth	B_R	$V_{AC2} = 20\text{mVRMS}$ (S2 closed)	-	4	-	kHz
Pin 9 Nominal Current	I_{P9}	$V_{P9} = 0\text{V}$	0.70	1.00	1.30	μA
Current Range	I_{RANGE}	(Note 2, 3)	8	10	12	
Slope		(Note 2, 4)	0.75	1	1.25	
Rectifier Threshold	V_{TH}	$f = 100\text{Hz}$ (Note 2, 5)	1.7	2.5	2.8	mV_{DC}
Corner Frequency	f_c	(Note 2, 6)	140	200	260	Hz

All Conditions and Parameters remain as show in Test Circuit unless otherwise specified in CONDITIONS Column.

V_{QX} - quiescent (unbias) voltage measured on the pin, (nothing connected to the pin). V_{PX} - actual voltage measured on the pin at given condition (X is pin number).

NOTES:

- $A_{REC} = 1.9375 \times (V_{P4} / V_{P3}) [V_{IN} = 10\text{mVRMS}] - 0.9375 \times (V_{P4} / V_{P3}) [V_{IN} = 18\text{mVRMS}]$
- $I_{D0} = I_{P9} [V_{P9} = 0]$; $I_{D1} = I_{P9} [V_{P4} = V_{Q4} + 35\text{mV}; V_{P9} = 0]$
 $I_{D2} = I_{P9} [V_{P4} = V_{Q4} + 85\text{mV}; V_{P9} = 0]$; $I_{D3} = I_{P9} [V_{P4} = V_{Q4} + 180\text{mV}; V_{P9} = 0]$
- $I_{RANGE} = I_{D3} / I_{D0}$
- $SLOPE = ((I_{D2} - I_{D1}) / 50\text{mV}) \times 14\text{k}\Omega$
- $V_{AL} = 85\text{mV} - ((I_{D2} - I_{D0}) / SLOPE) \times 14\text{k}\Omega$; $V_{AH} = 85\text{mV} + (50\text{mV} \times (I_{D3} - I_{D2}) / (I_{D2} - I_{D1}))$;
 $V_{P4} \leq V_{AL} [V_{IN} = 1.7\text{mVRMS}]$ and $V_{P4} \geq V_{AL} [V_{IN} = 2.8\text{mVRMS}]$
- $f_c = 1 / (2 \times \pi \times 1.41 \times 10\text{nF} \times R)$; $R = 26\text{mV} \times ((1 / I_{D0}) + (1 / (I_2 - I_{D0})))$
 $I_2 = ((3 \times (I_{D0} + I_{P9} [V_{P9} = V_{Q9} + 18\text{mV}]))) / (4 - ((I_{D0} + I_{P9} [V_{P9} = V_{Q9} + 18\text{mV}]) / (I_{D0} + I_{P9} [V_{P9} = V_{Q9} - 18\text{mV}])))$

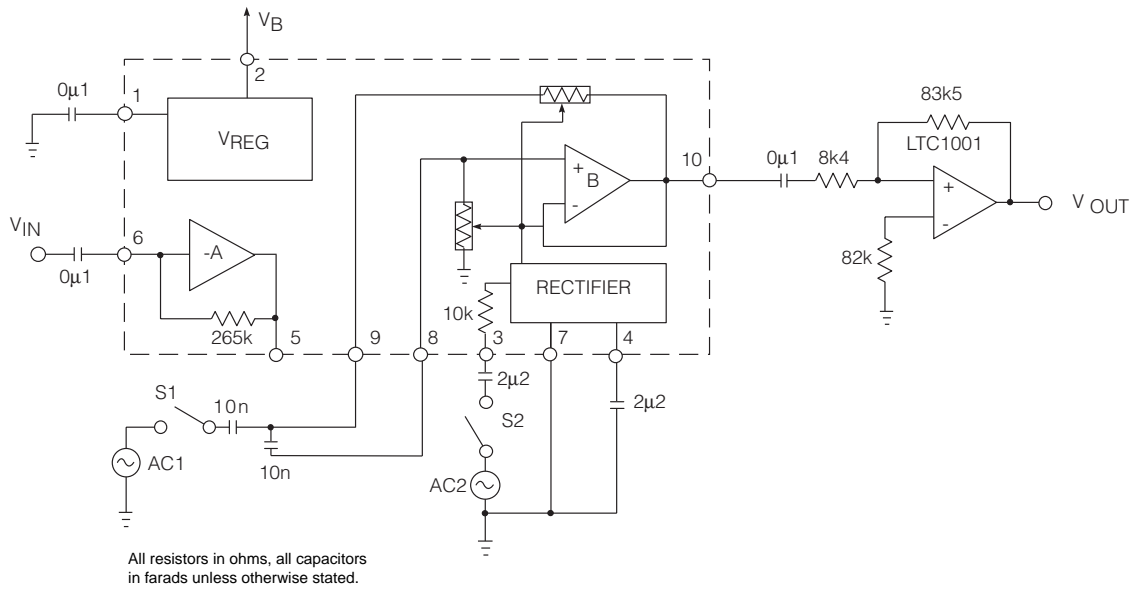

Fig. 1 Test Circuit

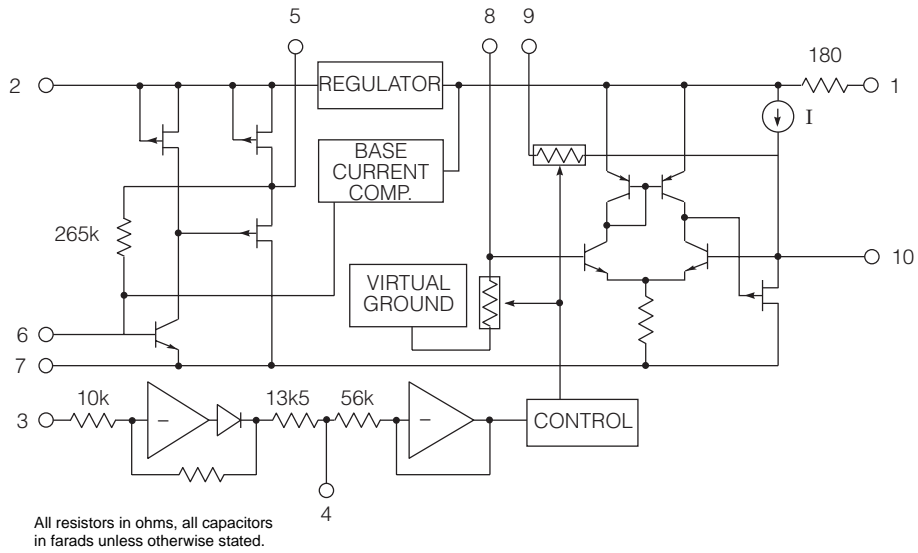

Fig. 2 Functional Schematic

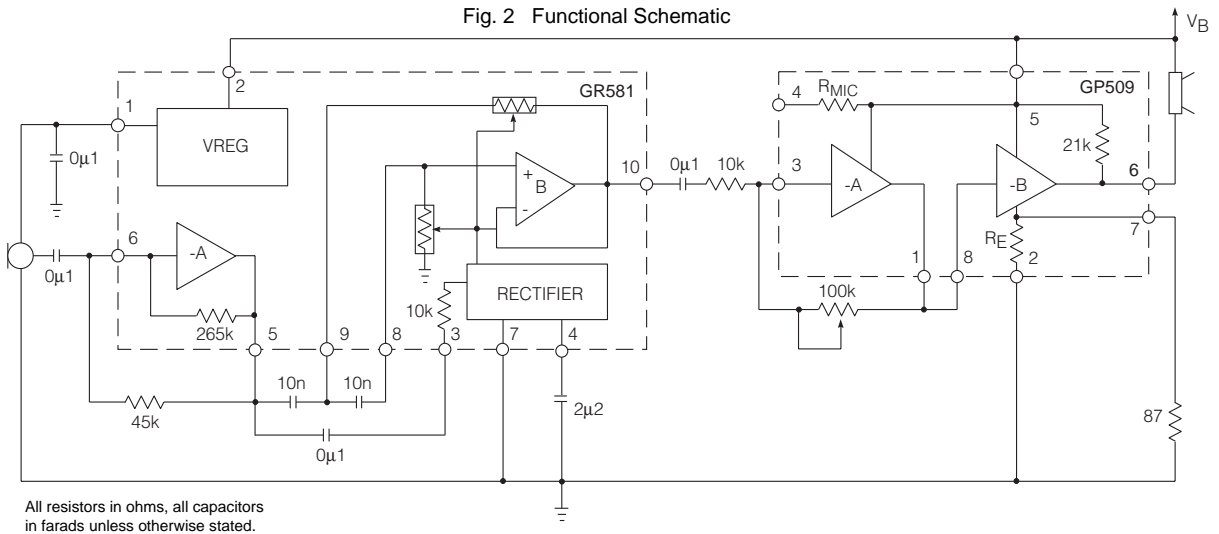

Fig. 3 Typical Hearing Instrument Application

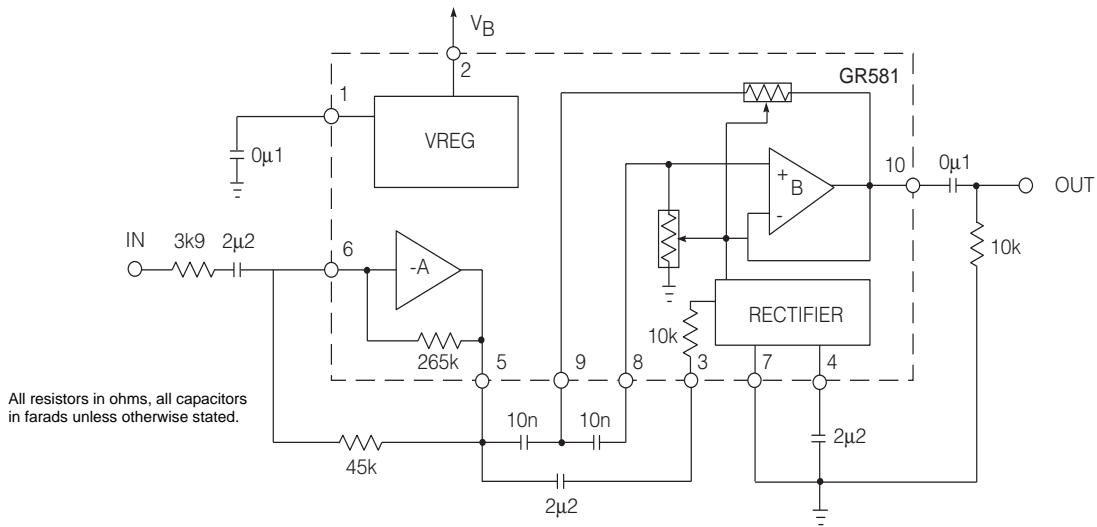

Fig. 4 Characterisation Circuit (used to generate typical curves)

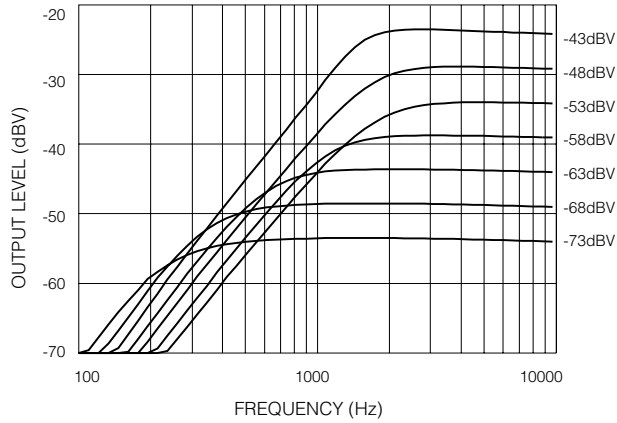

Fig. 5 Frequency Response

REVISION NOTES

Changes to standard packaging information.

DOCUMENT IDENTIFICATION

PRODUCT PROPOSAL

This data has been compiled for market investigation purposes only, and does not constitute an offer for sale.

ADVANCE INFORMATION NOTE

This product is in a development phase and specifications are subject to change without notice. Gennum reserves the right to remove the product at any time. Listing the product does not constitute an offer for sale.

PRELIMINARY DATA SHEET

The product is in a preproduction phase and specifications are subject to change without notice.

DATA SHEET

The product is in production. Gennum reserves the right to make changes at any time to improve reliability, function or design, in order to provide the best product possible.

Gennum Corporation assumes no responsibility for the use of any circuits described herein and makes no representations that they are free from patent infringement.

© Copyright August 1992 Gennum Corporation. All rights reserved. Printed in Canada.