

FEATURES

- 1.0 to 5 VDC operating range
- low current consumption (54 μ A)
- 1% electrical distortion
- typically 55 dB open loop gain
- low pin count (4 pin)
- ideal for active filtering

STANDARD PACKAGING

- 8 pin PLID®
- Chip size 27 x 25 mils

DESCRIPTION

The GS563 is a low noise, low current, inverting amplifier which utilizes Gennum's low voltage bipolar JFET technology.

The amplifier has a minimum open loop gain of 45 dB with the closed loop gain set by the ratio of feedback resistor to the input resistor. For a well controlled gain tolerance, it is recommended that the closed loop gain be at least 20 dB below the open loop gain.

The device is internally bias compensated, preventing any DC current flow via external feedback resistors. It is ideally suited for filtering applications and can be used as a drop in replacement for single transistor configurations.

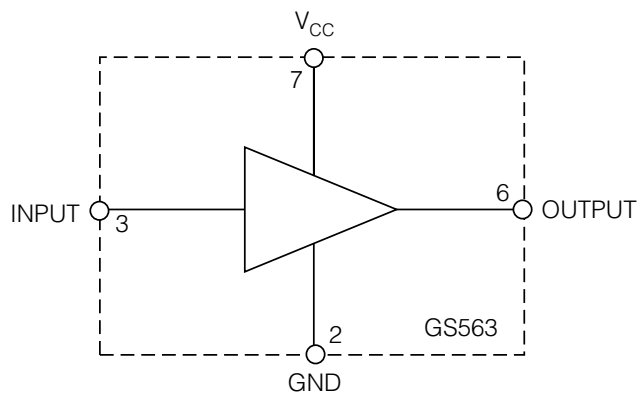

FUNCTIONAL BLOCK DIAGRAM

ABSOLUTE MAXIMUM RATINGS

PARAMETER	VALUE / UNITS
Supply Voltage	5V DC
Power Dissipation	25 mW
Operating Temperature	-10° to +40°C
Storage Temperature	-20° to +70°C

CAUTION
CLASS 1 ESD SENSITIVITY



PIN CONNECTIONS

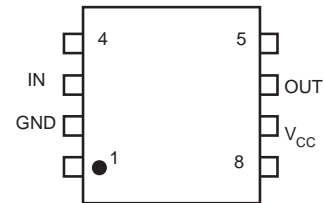

ELECTRICAL CHARACTERISTICS Stage = 1.3V Temperature = 25° C

PARAMETER	SYMBOL	CONDITIONS	MIN	TYP	MAX	UNITS
Amplifier Current	I_{AMP}		30	54	80	μA
Bias Voltage (Pin 3)	V_{Q3}		475	550	675	mV
Bias Current (Pin 3)	I_{BIAS}	See Note 1	-50	0	50	nA
Output Voltage Swing - High (Pin 3)	V_{OH}	S1 = c, S2 = b, S3 = b See Note 2	200	590	-	mV
Output Voltage Swing - Low (Pin 3)	V_{OL}	S1 = b, S2 = b, S3 = c See Note 3	200	258	-	mV
Open Loop Gain	A_{OL}	S1 = d, S2 = c, See Note 4	45	55	-	dB
Input Referred Noise	I.R.N.	Aweight S1 = d, S2 = c	-	1.0	2.5	μV
Distortion	THD	S1 = d, S2 = c, $V_{OUT} < 100 mV_{RMS}$	-	0.64	1.0	%
Supply Rejection	P_{SRR}	Open Loop	6	11	-	dB

All switch positions remain as shown in Test Schematic unless otherwise stated. V_F is the actual voltage measured on the pin at given condition.

V_Q - quiescent (unbias) voltage measured on the pad (nothing connected to the pin)

- Note:**
- $I_{BIAS} = (V_{P3} [S2 = b] - V_{Q3}) / 1M$
 - $V_{OH} = V_{P6} - V_{Q6}$
 - $V_{OL} = V_{Q6} - V_{P6}$
 - $A_{OL} = 20 \log (1 + R_F / R_S) - (20 \log ((R_F / R_S) (1 / (1 + R1 / R2)) (V_{IN} / V_{OUT}) - 1))$

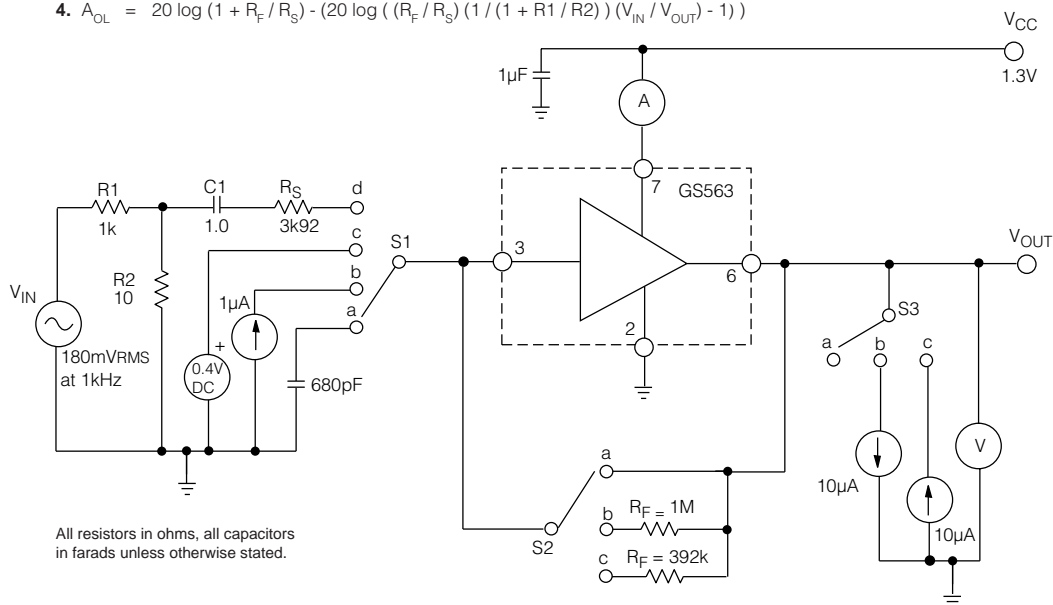

Fig. 1 GS563 Test Circuit

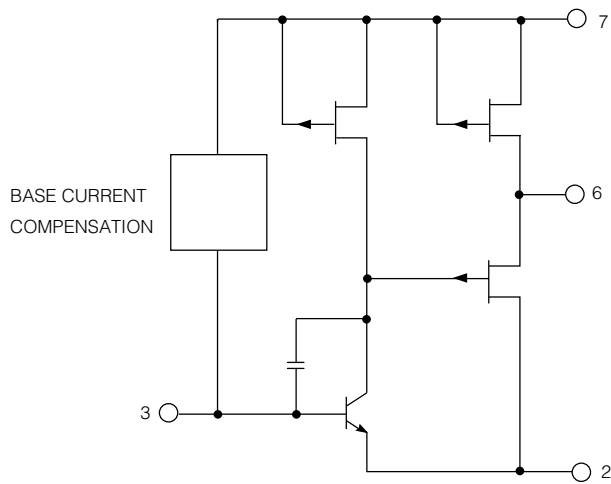
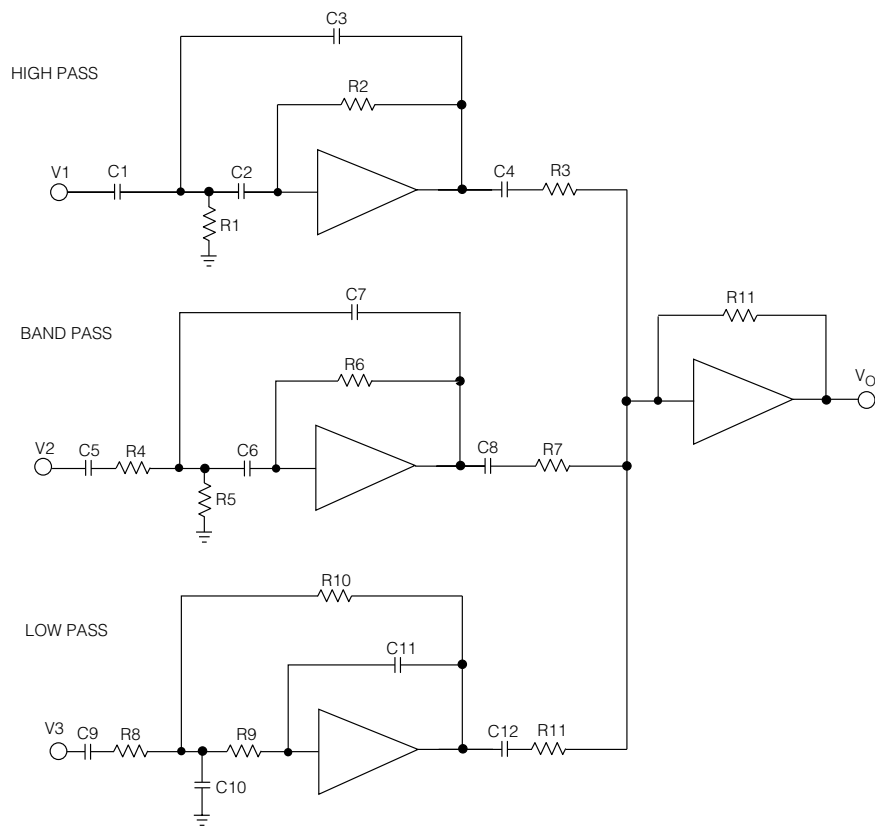
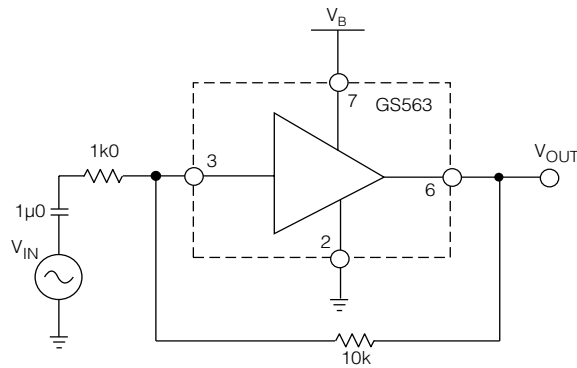

Fig. 2 Functional Schematic



(For Filter Design refer to Note 600-9, Active Filtering for Hearing Aids)
 All resistors in ohms, all capacitors in farads unless otherwise stated.

Fig. 3 Multi-Band Filtering Application



All resistors in ohms, all capacitors in farads unless otherwise stated.

Fig. 4 Characterization Circuit

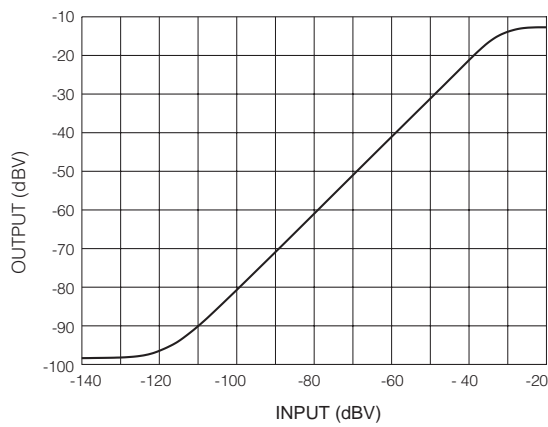

Fig. 5 Input vs Output

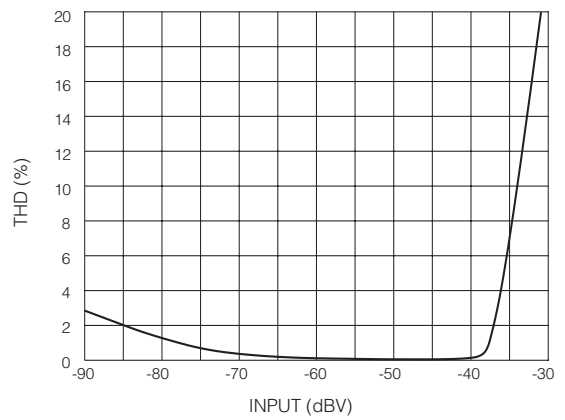

Fig. 6 THD vs Input Level

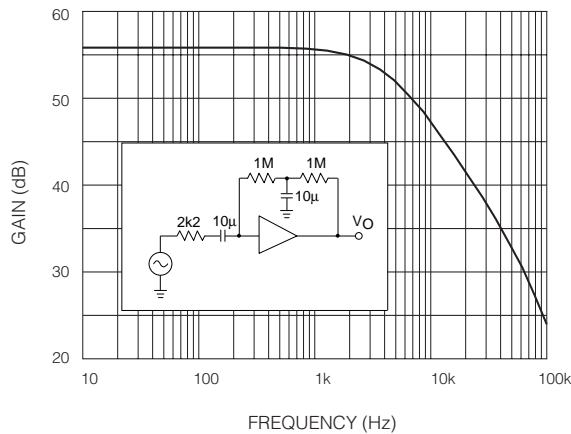
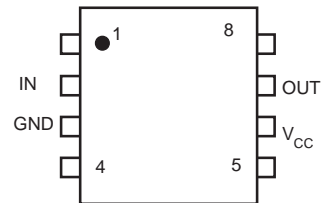

Fig. 7 Open Loop Voltage Gain



8 Pin DIP Pinout
(For evaluation purposes)

DOCUMENT IDENTIFICATION: DATA SHEET
The product is in production. Gennum reserves the right to make changes at any time to improve reliability, function or design, in order to provide the best product possible.

REVISION NOTES:
Updated to Data sheet