

FEATURES

- **small outline for CIC applications**
- **low input referred noise**
- **low current class A**
- **copper conductor output pads**

STANDARD PACKAGING

- Hybrid Typical Dimensions:
0.139 in x 0.078 in x 0.075 in
(3.53 mm x 1.98 mm x 1.91 mm)

DESCRIPTION

The GS3022 hybrid contains Gennum's GK509 class A amplifier and a single input coupling capacitor. The extremely small size of the hybrid allows it to easily fit into many CIC and ITC applications.

Block A of the GK509 is a low noise inverting amplifier with an open loop voltage gain of typically 56 dB. The closed loop gain is set by the ratio of input resistance to feedback resistance.

The output stage is a class A current drive amplifier. The current that flows in the transducer is the ratio of the 30 mV reference voltage to the resistance to ground at pad 1 on the hybrid. With no external R_E the transducer current is typically 240 μ A, which makes it suitable for high impedance receivers.

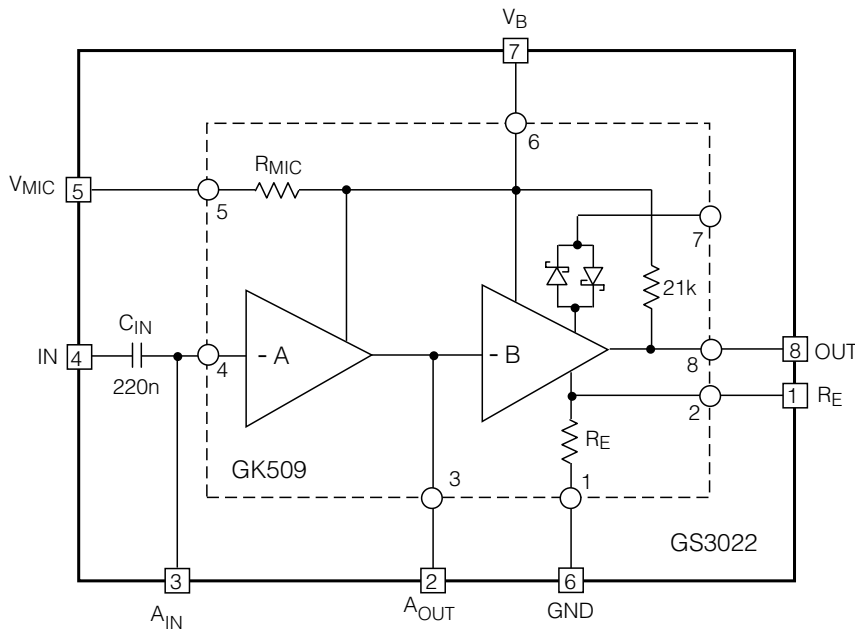

All resistors in ohms, all capacitors in farads unless otherwise stated.

BLOCK DIAGRAM

ABSOLUTE MAXIMUM RATINGS

| PARAMETER | VALUE & UNITS |
|-----------------------|----------------|
| Supply Voltage | 3 V DC |
| Power Dissipation | 25 mW |
| Operating Temperature | -10 to + 40 °C |
| Storage Temperature | -20 to +70 °C |

CAUTION
CLASS 1 ESD SENSITIVITY



PAD CONNECTION

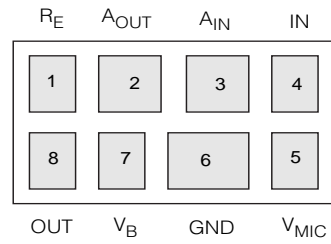

ELECTRICAL CHARACTERISTICS

Conditions: Temperature 25 °C, Frequency = 1 kHz.

| PARAMETER | SYMBOL | CONDITION | MIN | TYP | MAX | UNITS |
|-----------------------------------|-------------|--------------------|------|-----|------|-----------|
| Amplifier Current | I_{AMP} | | 55 | 100 | 145 | μA |
| Transducer Current | I_{TRANS} | | 170 | 230 | 290 | μA |
| Microphone Supply Voltage (pad 5) | V_{MIC} | | - | 1.3 | - | V |
| Emitter Bias Voltage (pad 1) | V_{RE} | | 21.5 | 30 | 35.5 | mV |
| On-chip Microphone Resistor | R_{MIC} | | 3 | 4 | 5 | $k\Omega$ |
| On-chip Emitter Resistor | R_E | | 90 | 125 | 160 | Ω |
| Voltage Gain | V_{GAIN} | $V_{IN} = -70$ dBV | 56 | 58 | 60 | dB |

(All conditions and parameters remain as shown in test circuit unless stated in condition column)

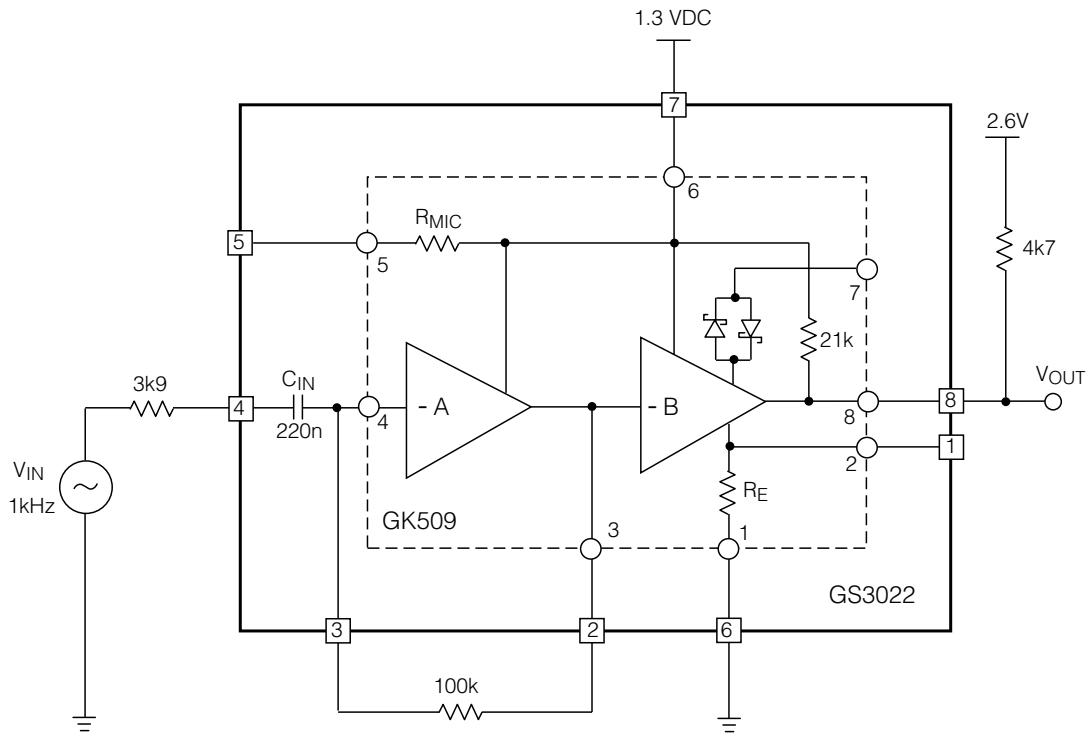

All resistors in ohms, all capacitors in farads unless otherwise stated.

Fig. 1 Production Test Circuit

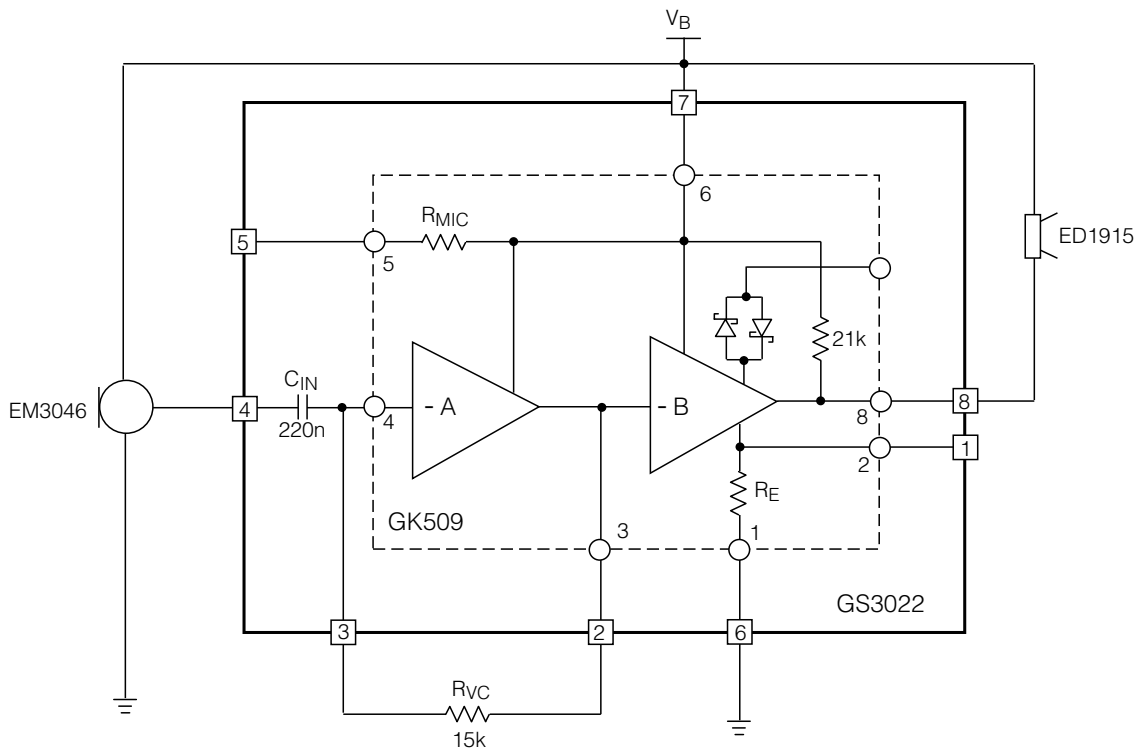

All resistors in ohms, all capacitors in farads unless otherwise stated.

Fig. 2 Typical CIC Hearing Instrument Application

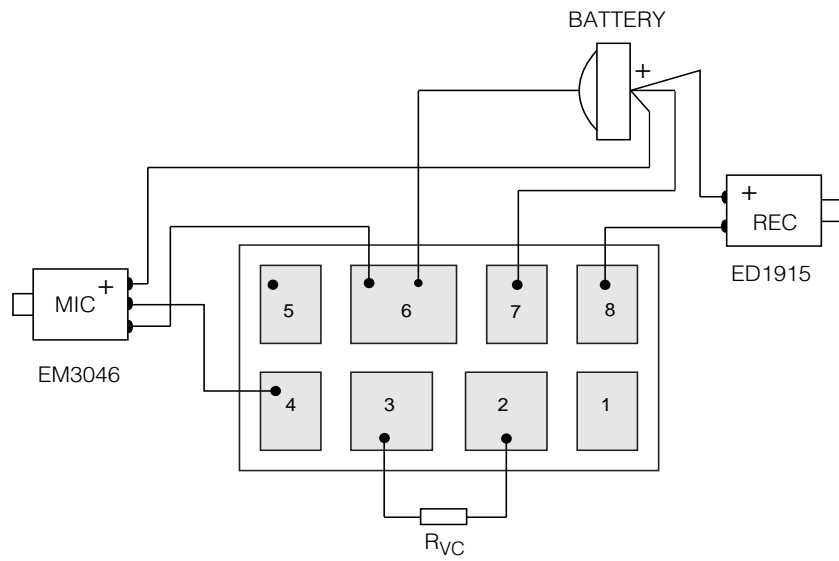
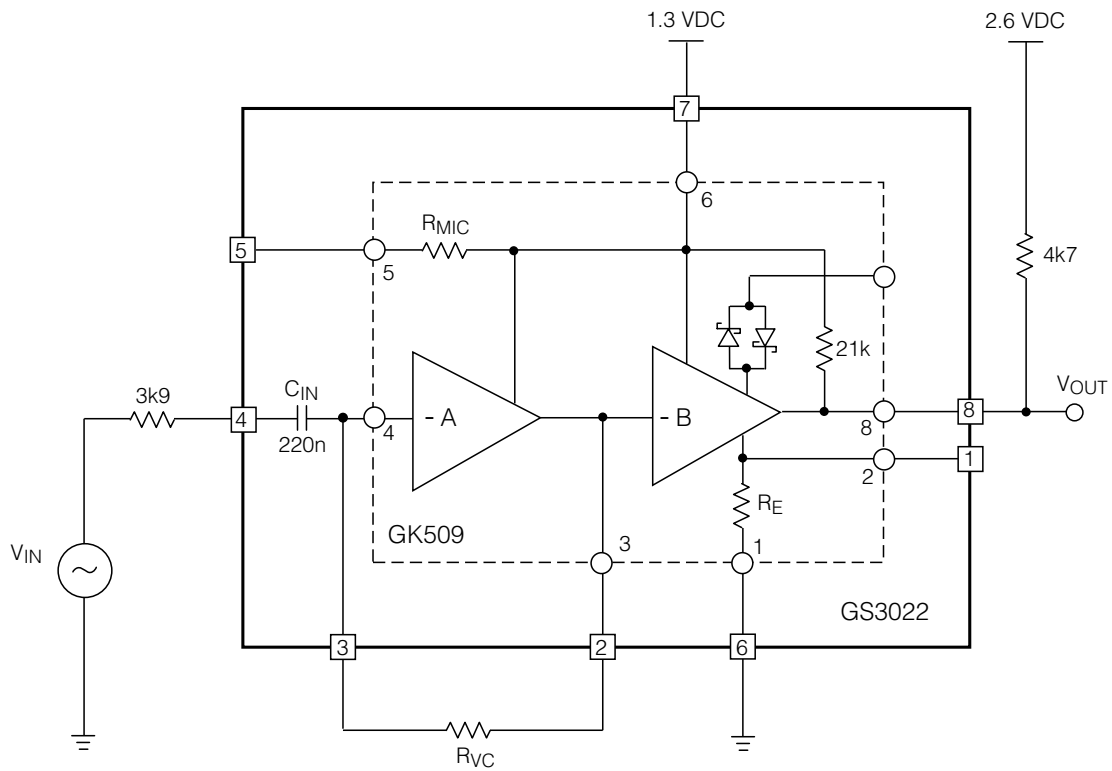

Fig. 3 Typical Hearing Instrument Assembly Diagram



All resistors in ohms, all capacitors in farads unless otherwise stated.

Fig. 4 Characterization Circuit (used to generate typical curves)

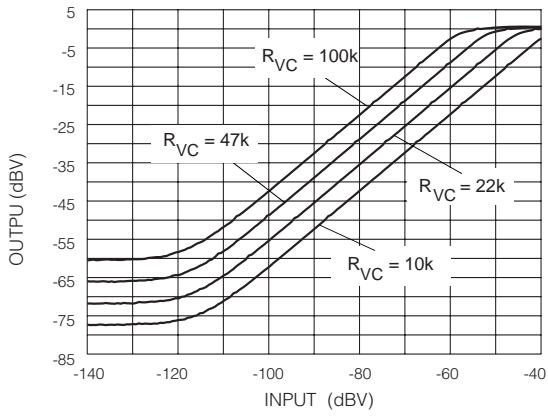

Fig. 5 Input vs Output (at 1kHz)

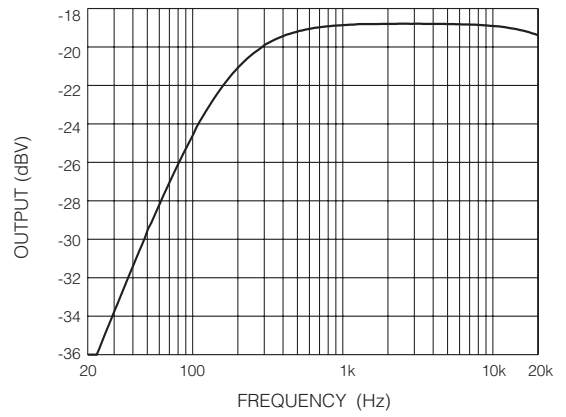

Fig. 6 Frequency Response
($R_{VC}=47k$, $V_{IN}=-70dBV$)

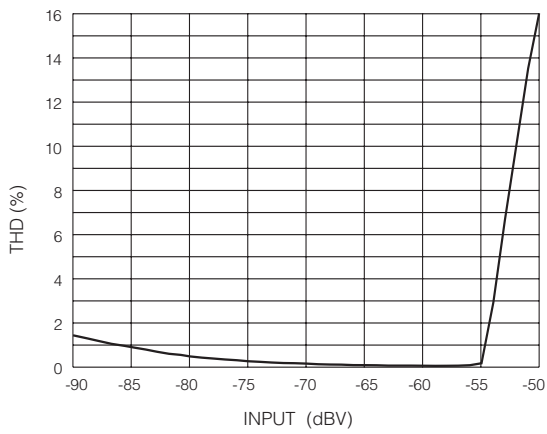

Fig. 7 THD vs Input ($R_{VC}=47k$)

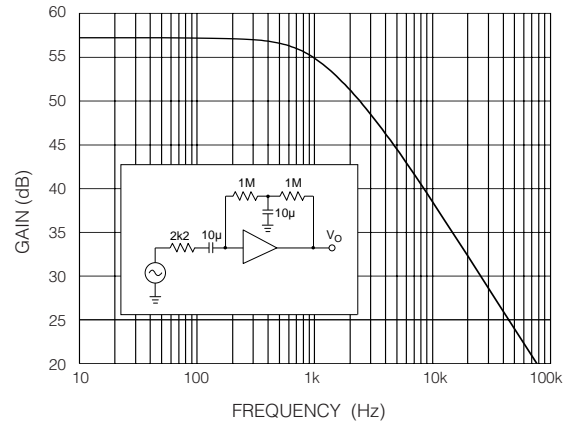
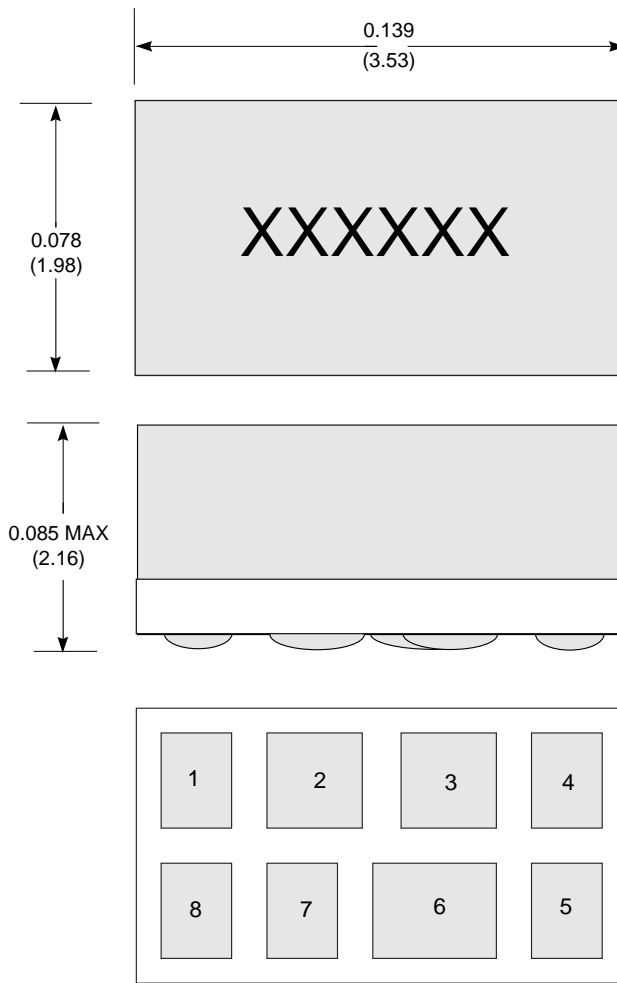

Fig. 8 Open Loop Frequency Response (Block A)



Dimensioning units are inches.
 Dimensions shown in parenthesis are in millimetres, converted from inches and include minor round off errors.
 1.0000 inches = 25.400mm.
 Dimension ± 0.005 (+0.13) unless otherwise stated.
 Pad numbers and capacitor numbers for illustration only.
 Smallest pad 0.020 x 0.027 (pad 4).
 Largest pad 0.034 x 0.027 (pad 6).
 XXXXXX - work order number.
 This hybrid is designed for point to point manual soldering.

Fig. 9 Hybrid Layout and Dimensions

DOCUMENT IDENTIFICATION: DATA SHEET
 The product is in production. Genum reserves the right to make changes at any time to improve reliability, function or design, in order to provide the best product possible.

REVISION NOTES:
 Updated to Data sheet