

**FEATURES**

- dual channel signal processing
- 2nd (4th) order state variable filter
- adjustable crossover frequency
- adjustable compression ratio from 1:1 to 4:1
- independent compression ratio adjustment for low and high frequency band
- adjustable AGC threshold levels
- unique twin average detectors
- handles high input levels
- low THD and IMD distortion
- drives Class D Integrated Receivers
- MPO range externally adjustable

**DEVICE DESCRIPTION**

The DynamEQ® II hybrid family is a second generation Wide Dynamic Range Compression (WDRC) system.

GS3031 (GS3032) hybrid incorporates 12 dB/oct (24 dB/oct) filtering. All capacitors necessary for operation are included on the hybrid.

The gain and frequency response is dependant on the user's environment.

Twin Averaging Detector circuits are optimized for sound quality during normal listening without sacrificing comfort during sudden loud inputs.

All input signals to DynamEQ® II, are processed by 2:1 compression before subsequent band splitting.

The 12 dB/oct (24 dB/oct) band split filter ahead of the expander/compressor circuits allows for independent compression ratio adjustment (1:1 to 4:1) in high and low frequency channels.

The gain setting stage is followed by a class D Integrated Receiver preamplifier stage. Symmetrical peak clipping is used to achieve MPO adjustment.

**STANDARD PACKAGING**

Hybrid Typical Dimensions

0.250 in x 0.115 in x 0.080 in  
(6.35 mm x 2.91 mm x 2.03 mm)

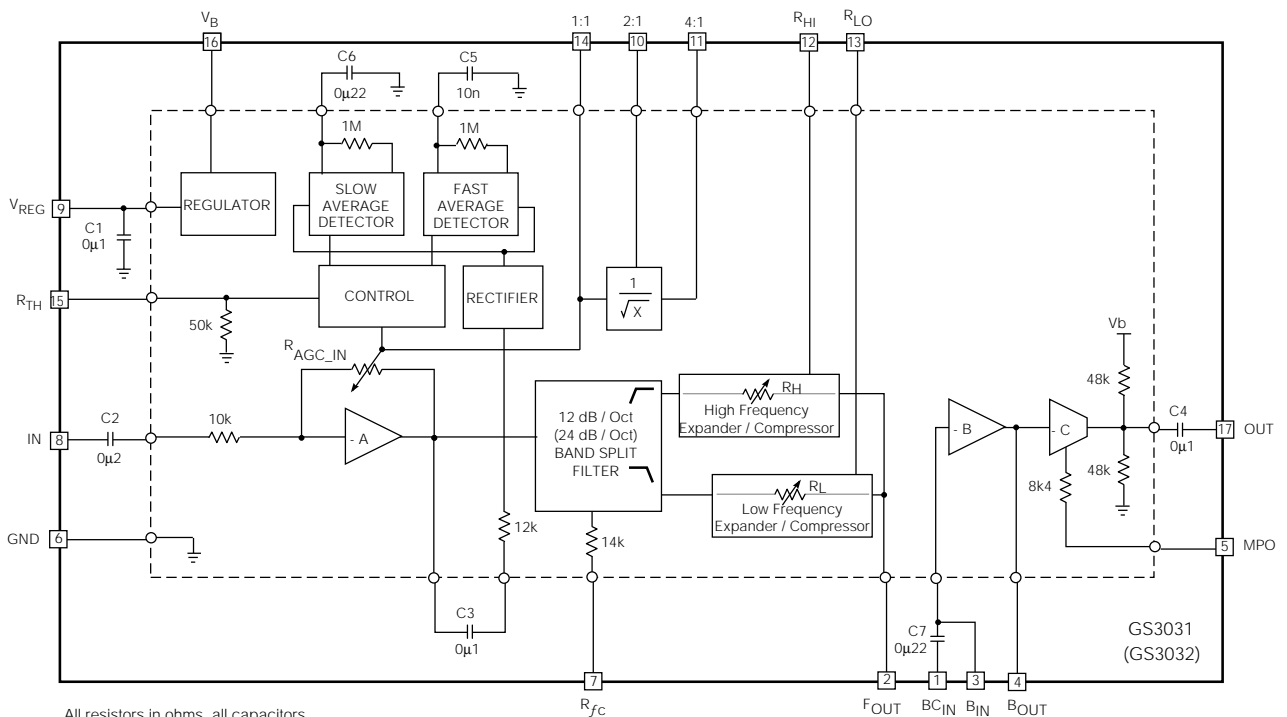

All resistors in ohms, all capacitors  
in microfarads, unless otherwise stated  
Patent Pending

**FUNCTIONAL BLOCK DIAGRAM**

## ABSOLUTE MAXIMUM RATINGS

PARAMETER	VALUE / UNITS
Supply Voltage	3 VDC
Power Dissipation	25 mW
Operating Temperature Range	-10° C to 40° C
Storage Temperature Range	-20° C to 70° C

**CAUTION**  
CLASS 1 ESD SENSITIVITY



## PAD CONNECTION

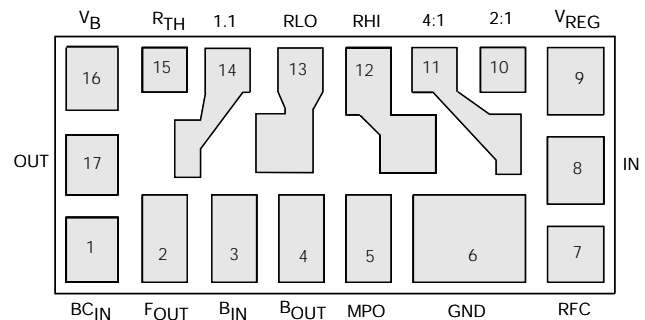

## ELECTRICAL CHARACTERISTICS

Conditions: Supply Voltage  $V_B = 1.3$  V, Frequency = 1 kHz, Temperature = 25°C

PARAMETER	SYMBOL	CONDITIONS	MIN	TYP	MAX	UNITS
Hybrid Current	$I_{AMP}$		-	370	530	$\mu$ A
Minimum Voltage	$V_b$		1.1	-	-	V
Total Harmonic Distortion	THD	$V_{IN} = -40$ dBV at 1kHz	-	0.2	1.0	%
THD with Maximum Allowable Input	$THD_M$	$V_{IN} = -23$ dBV, $R_{vc} = 47$ k $\Omega$	-	2	10	%
Input Referred Noise	IRN	Aweight	-	3.0	-	$\mu$ V <sub>RMS</sub>
Total System Gain	$A_V$	$V_{IN} = -90$ dBV	46	49	52	dB
Regulator Voltage	$V_{REG}$	$I_{LOAD} = 30$ $\mu$ A	890	930	1000	mV
<b>AGC</b>						
Lower Threshold	$TH_{LO}$		-91	-87	-83	dBV
Upper Threshold	$TH_{HI}$		-36	-32	-28	dBV
Compression Gain Range	$\Delta A$	Gain(-90dBV <sub>IN</sub> ) - Gain(-30dBV <sub>IN</sub> )	37.5	40.5	43.5	dB
System Gain in Compression	$A_{60}$	$V_{IN} = -60$ dBV	26	29	32	dB
Min. Compression Ratio	$CMP_{1:1}$	$V_{IN} = 3$ kHz, -60dBV to -40dBV, $R_{hp} = 1:1$ $R_{lp} = 1:1$	0.9	1.0	1.1	Ratio
Max. Comp. Ratio	$CMP_{4:1}$	$V_{IN} = 3$ kHz, -60dBV to -40dBV, $R_{hp} = 4:1$ $R_{lp} = 4:1$	3.6	4.0	4.3	Ratio
Fast Detector Time Constant	$\tau_{FAST}$		-	10	-	ms
Slow Detector Time Constant	$\tau_{SLOW}$		-	220	-	ms
<b>FILTER</b>						
Maximum Cross-over Frequency	$f_{c,0}$	$R_{fc} = 0\Omega$	3.0	3.9	-	kHz
Nominal Cross-over Frequency	$f_{c,22}$	$R_{fc} = 22$ k $\Omega$	1.5	1.9	2.3	kHz
Minimum Cross-over Frequency	$f_{c,220}$	$R_{fc} = 220$ k $\Omega$	-	0.9	1.4	kHz
Filter Rolloff Rate (GS3027)			-	12	-	dB/oct
(GS3028)			-	24	-	dB/oct
<b>STAGE A and B</b>						
Open Loop Gain (B)	$A_{OL,B}$		-	52	-	dB
Input Impedance (A)	$R_{IN}$		9	11	13	k $\Omega$
<b>OUTPUT STAGE</b>						
Stage Gain	$A_C$	$V_{IN} = -30$ dBV	7	9	11	dB
Max Output Level	MPO	$R_{VC} = 220$ k $\Omega$ , $V_{IN} = -25$ dBV	-14.5	-12.5	-10.5	dBV
MPO Range	$\Delta MPO$	$R_{MPO} = 0\Omega$ to 50k $\Omega$	13	15	17	dB
Output Resistance	$R_{OUT}$		-	24	-	k $\Omega$

All conditions and parameters remain as shown in Test Circuit unless otherwise stated in "Conditions" column.

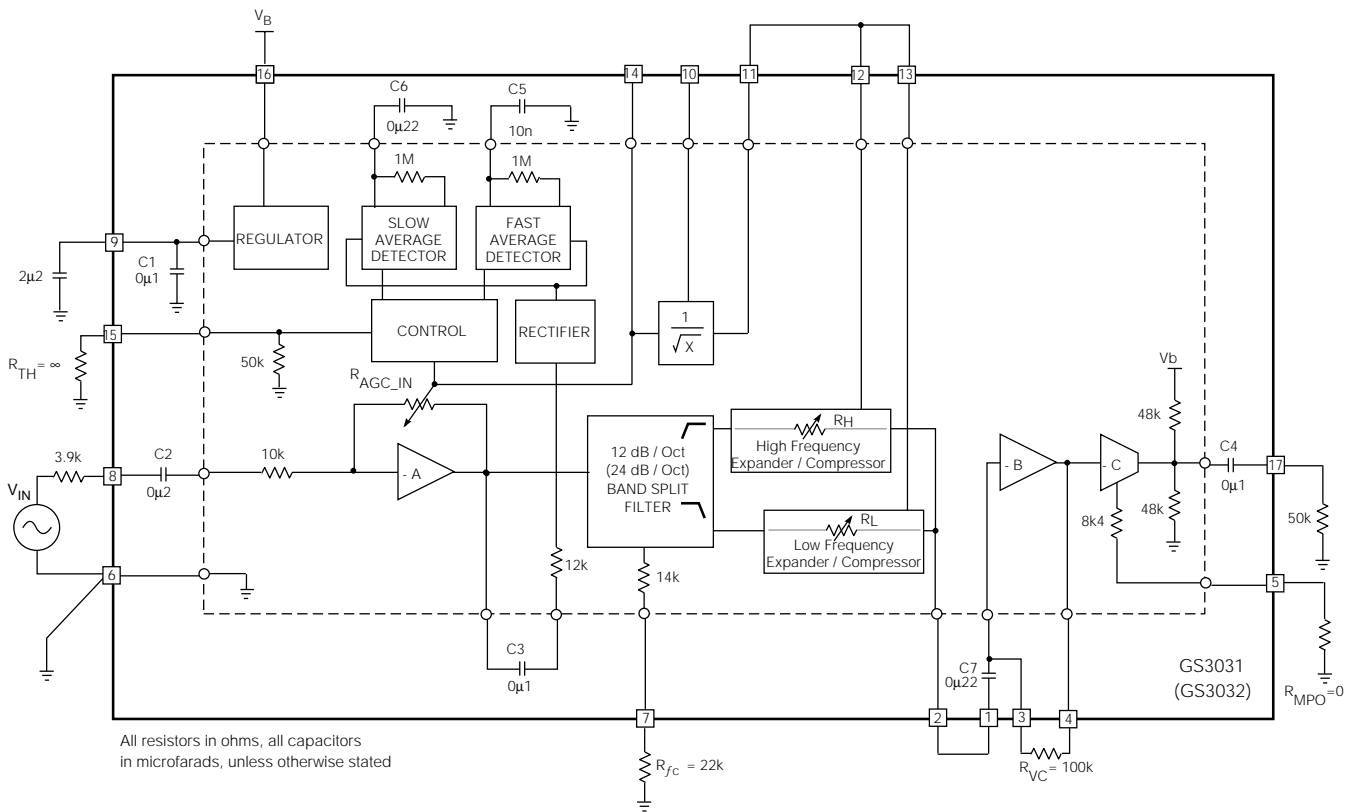

Fig. 1 Production Test Circuit

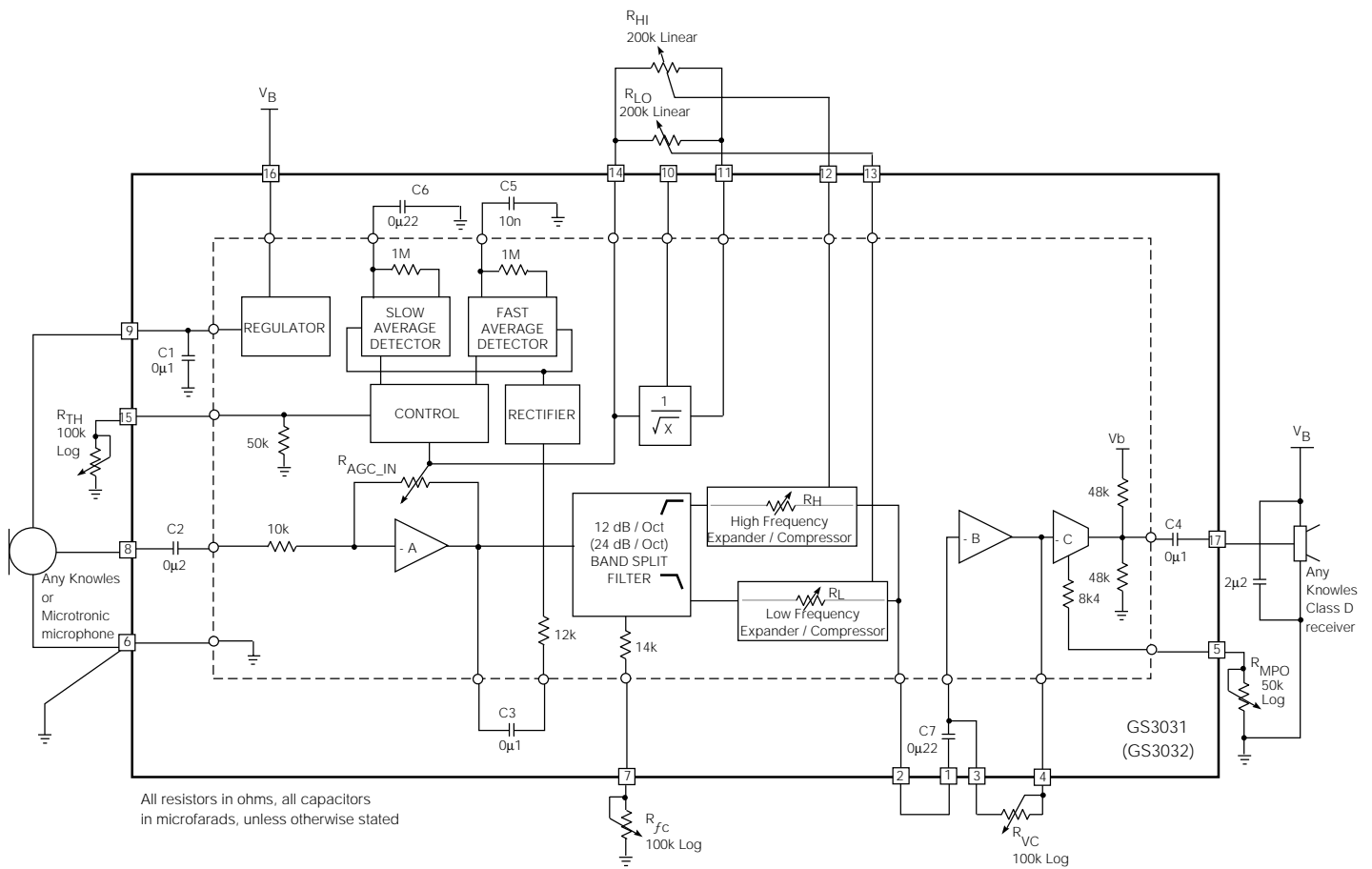

Fig. 2 Maximum Flexibility Hearing Instrument Application

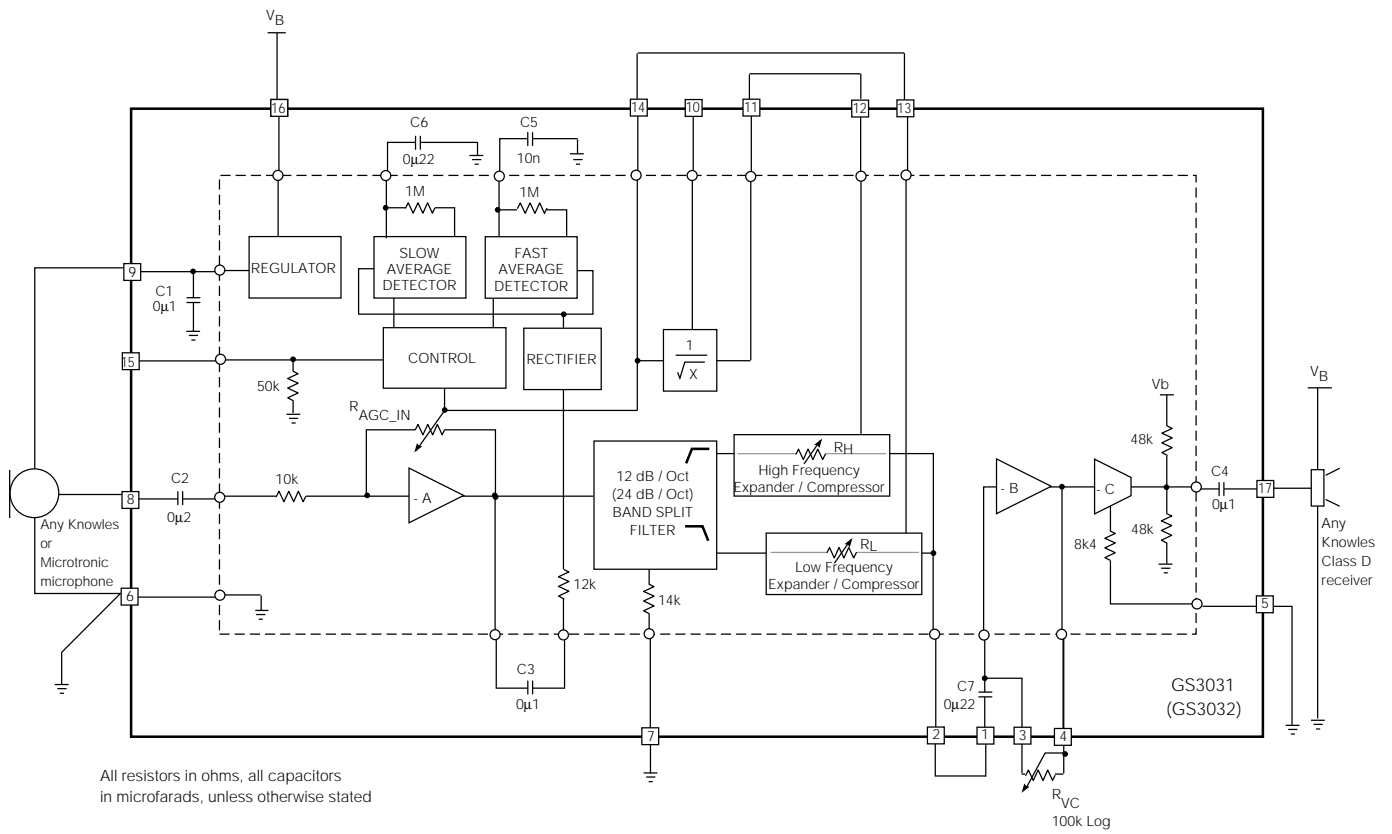

Fig. 3 Minimum Component Hearing Instrument Application

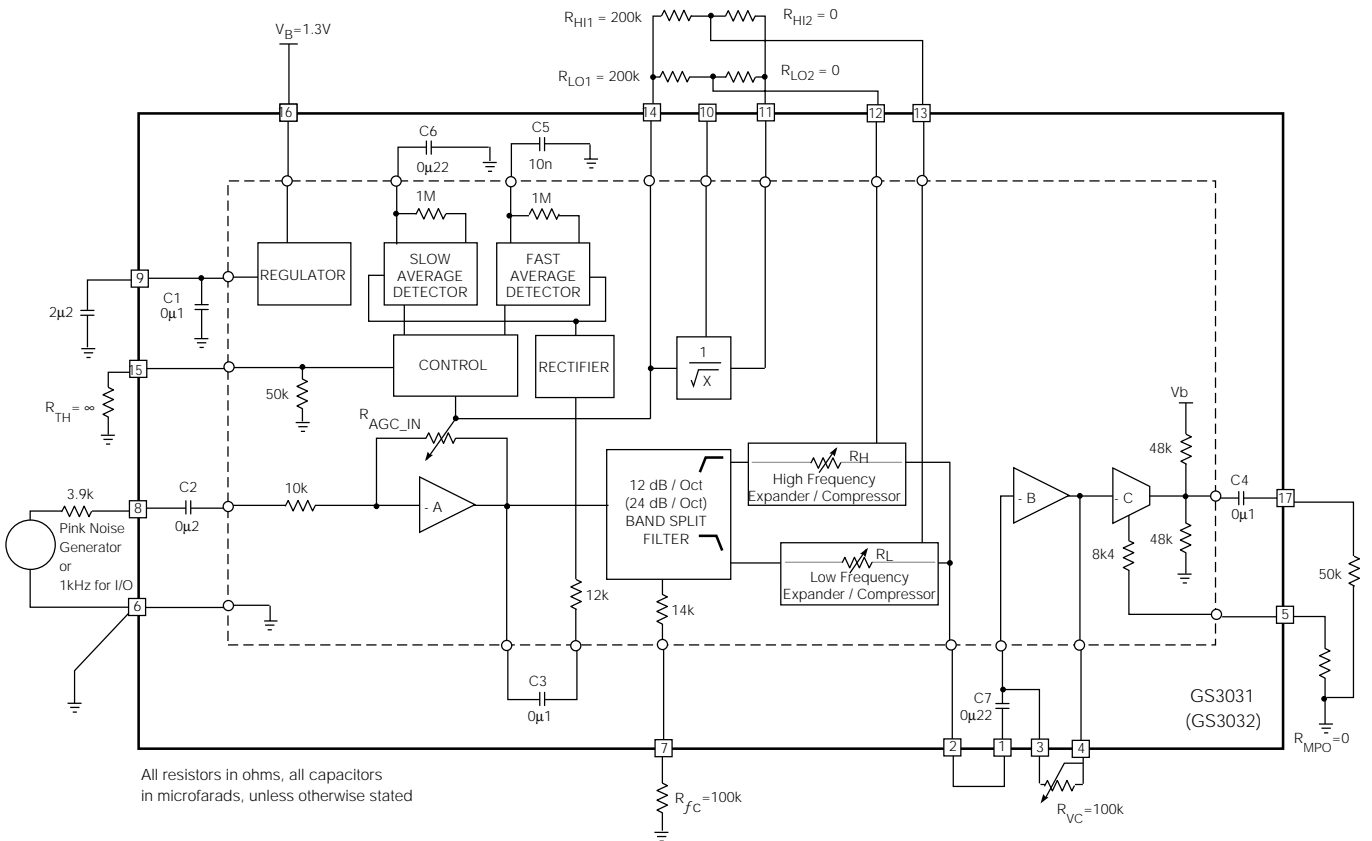
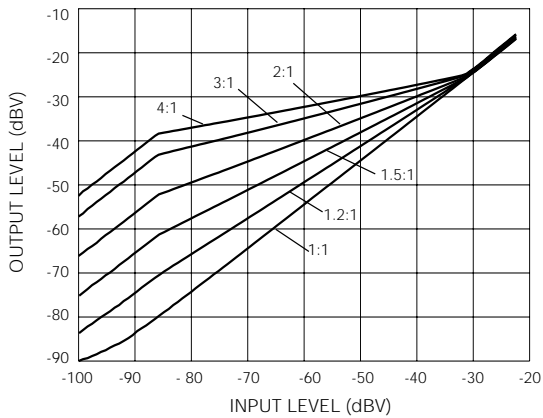
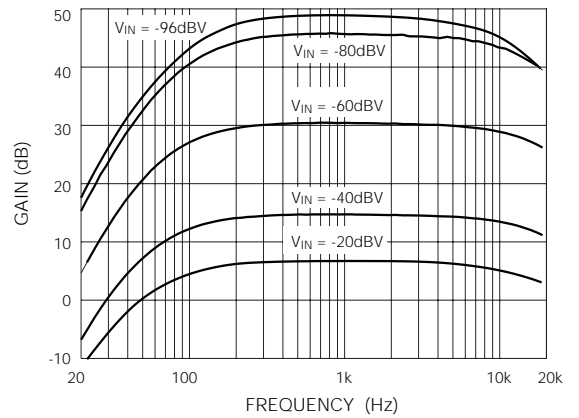

Fig. 4 Characterization Circuit (Used to generate typical curves)

**TYPICAL PERFORMANCE CURVES**



**Fig. 5 I/O Transfer function for Different Compression Ratios**



**Fig. 6 Frequency Response for Different Input Levels**

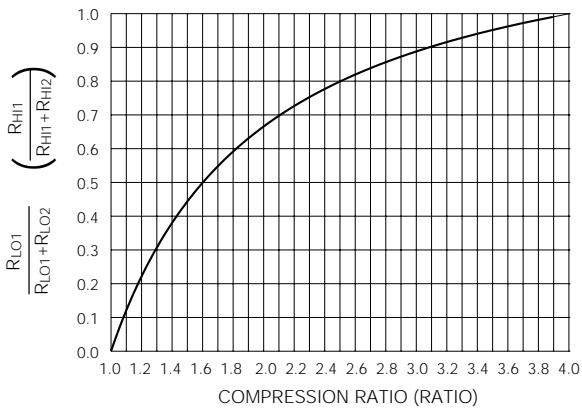

**Fig. 7 Compression Settings Resistor Ratio for High Pass Channel ( $R_{H1}$  &  $R_{H2}$ ) and Low Pass Channel ( $R_{L01}$  &  $R_{L02}$ )**

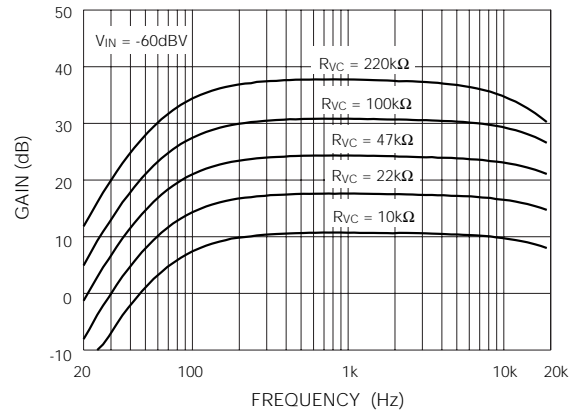

**Fig. 8 Frequency Response for Different  $R_{VC}$  Values**

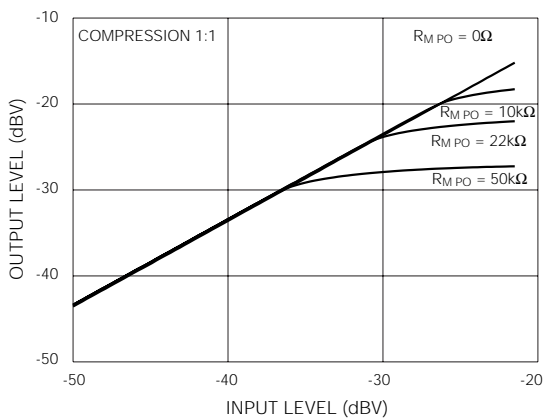

**Fig. 9 I/O Transfer Function for Different  $R_{MPO}$  Resistors**

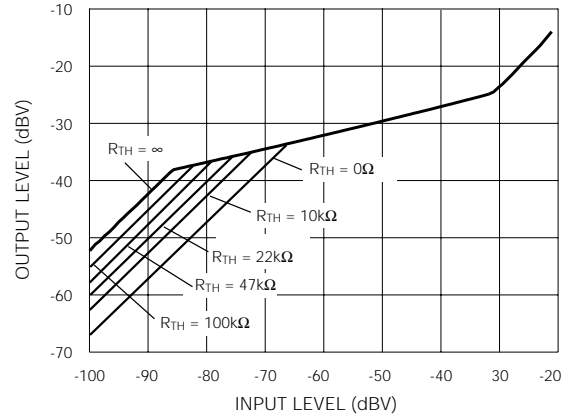

**Fig. 10 I/O Transfer Function for Different  $R_{TH}$  Resistors**

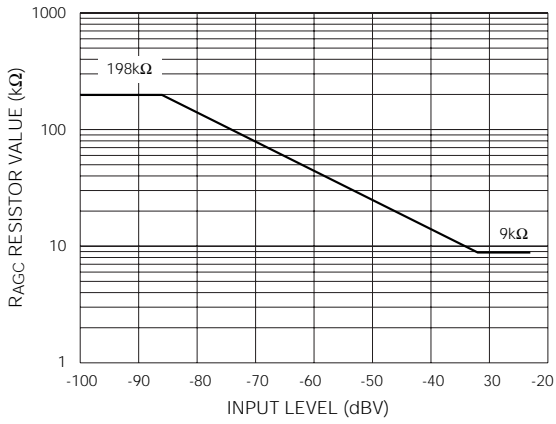

Fig. 11 Stage A Compressor Feedback Resistor Value

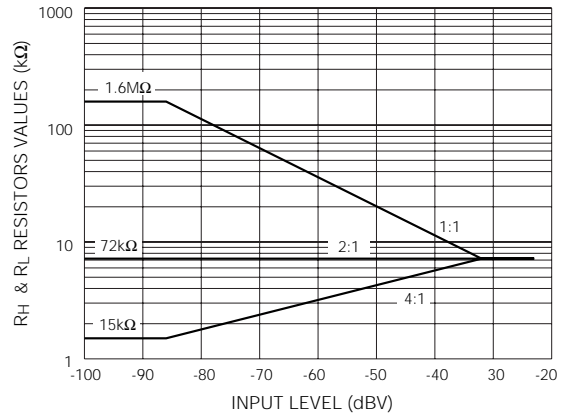

Fig. 12 Expander / Compressor Resistors Values

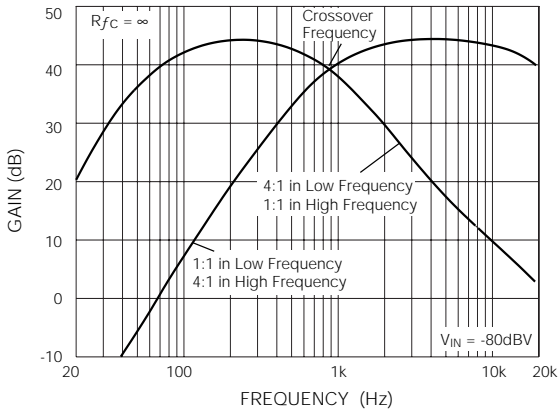

Fig. 13 Crossover Frequency Representation for GS3031 Processor

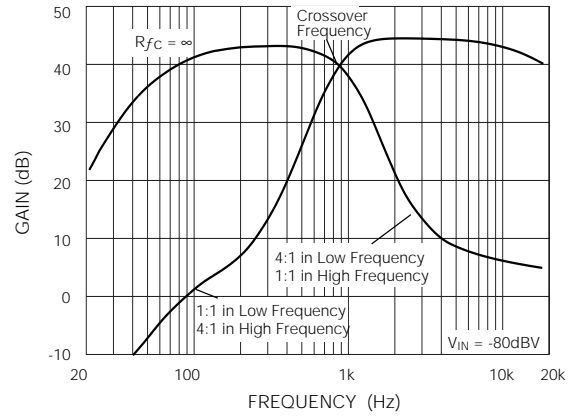

Fig. 14 Crossover Frequency Representation for GS3032 Processor

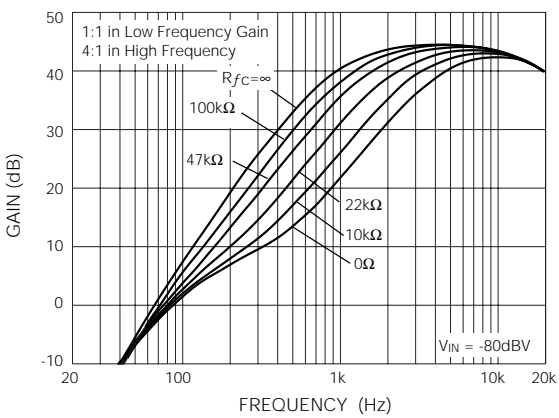

Fig. 15 GS3031 Frequency Response for Different  $R_{fc}$  Resistor Values

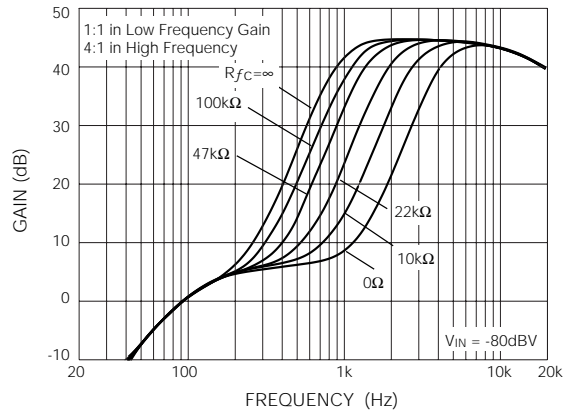

Fig. 16 GS3032 Frequency Response for Different  $R_{fc}$  Resistor Values

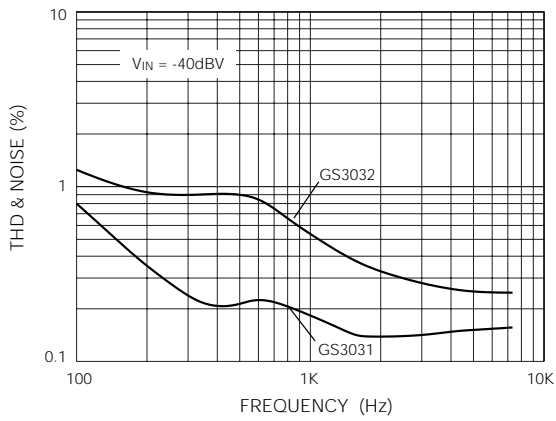

Fig. 17 THD and Noise vs Frequency

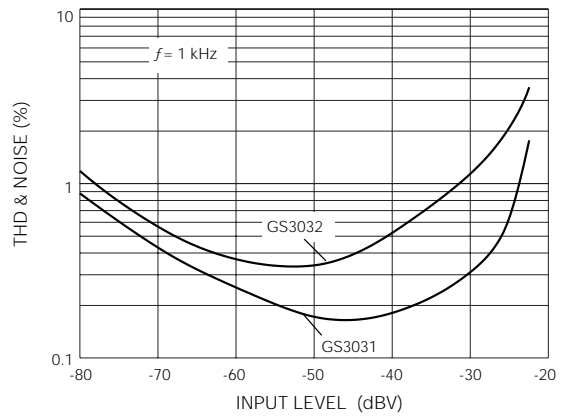

Fig. 18 THD and Noise vs Input Level

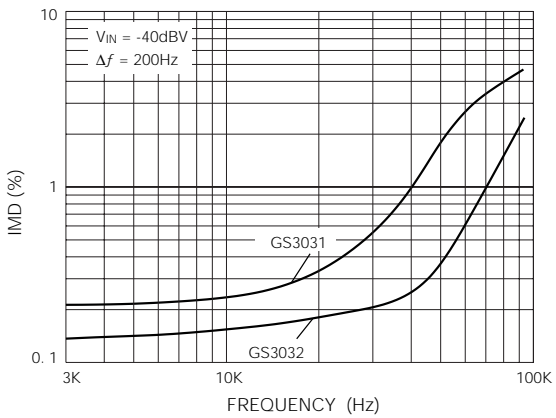

Fig. 19 Intermodulation Distortion (CCIF) vs Frequency

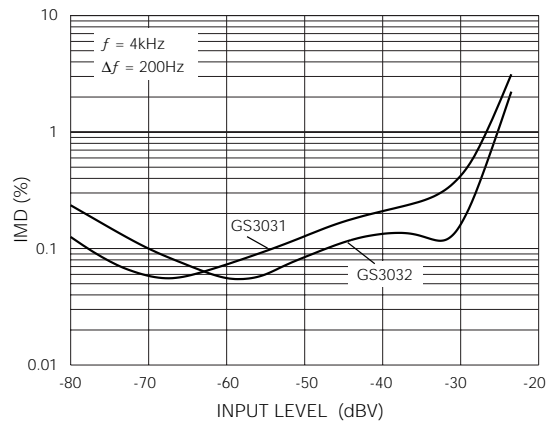
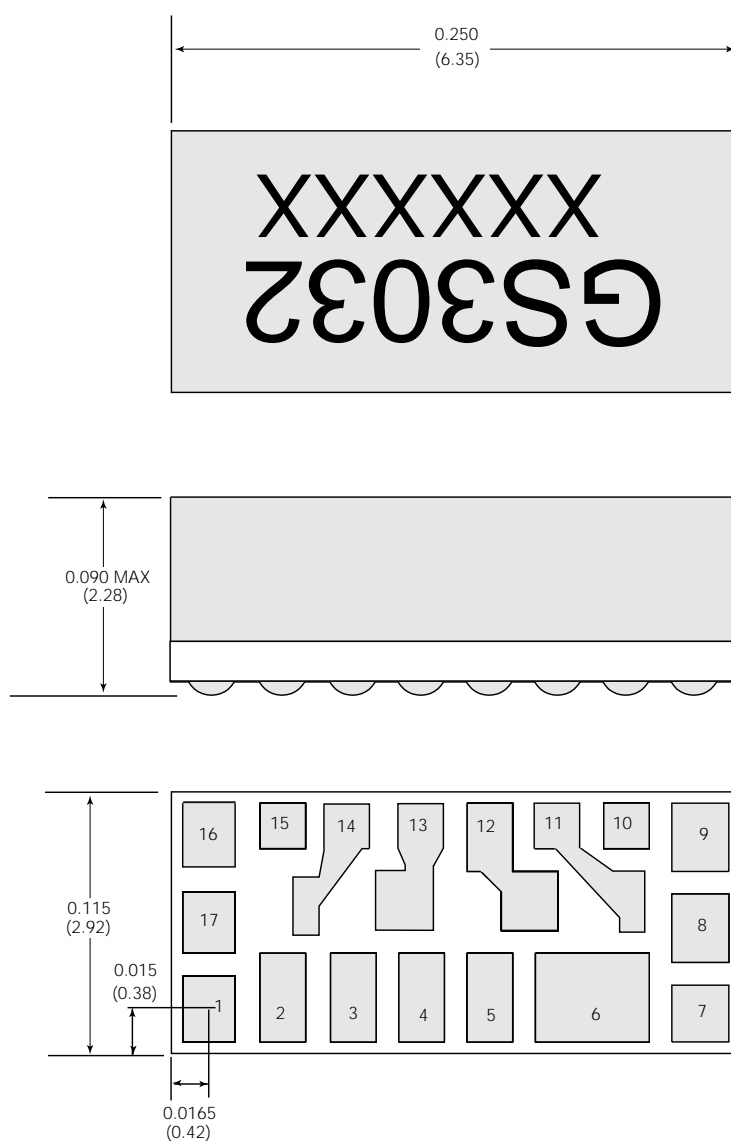

Fig. 20 Intermodulation Distortion (CCIF) vs Input Level



Dimension units are in inches.  
 Dimensions in parenthesis are in millimetres converted from inches and include minor rounding errors.  
 1.0000 inches = 25.400 mm.  
 Dimension  $\pm 0.003$  ( $\pm 0.08$ ) unless otherwise stated.  
 XXXXXX - work order number.  
 Component name - either GS3031 or GS3032  
 This hybrid is designed for point to point soldering.  
 Contact Gennum Representative for pad layout in electronic format.

Fig. 21 Hybrid Layout & Dimensions

GENNUM CORPORATION  
 MAILING ADDRESS:  
 P.O. Box 489, Stn. A, Burlington, Ontario, Canada L7R 3Y3  
 Tel. +1 (905) 632-2996 Fax +1 (905) 632-2814  
 SHIPPING ADDRESS:  
 970 Fraser Drive, Burlington, Ontario, Canada L7L 5P5

GENNUM JAPAN CORPORATION  
 C-101, Miyamae Village, 2-10-42 Miyamae, Suginami-ku, Tokyo 168-0081,  
 Japan Tel. +81 (3) 3334-7700 Fax: +81 (3) 3247-8839

**DOCUMENT IDENTIFICATION: DATA SHEET**

The product is in production. Gennum reserves the right to make changes at any time to improve reliability, function or design, in order to provide the best product possible.

**REVISION NOTES:**

Updated to Data sheet

Gennum Corporation assumes no responsibility for the use of any circuits described herein and makes no representations that they are free from patent infringement.

© Copyright September 1995 Gennum Corporation. All rights reserved.

Printed in Canada.