

### FEATURES

- SMPTE 259M compliant
- operational to 540Mb/s
- automatic cable equalization (typically greater than 350m of high quality cable at 270Mb/s)
- adjustment-free operation
- auto-rate selection (5 rates) with manual override
- single external VCO resistor for operation with five input data rates
- data rate indication output
- system friendly: serial data outputs muted and serial clock remains active when input data is lost
- operation independent of SAV/EAV sync signals
- signal strength indicator output
- output 'eye' monitor (OEM) with large signal amplitude and power down option
- carrier detect with programmable threshold level
- power savings mode (output serial clock disable)
- 44 pin MQFP

### APPLICATIONS

Cable equalization plus clock and data recovery for all high speed serial digital interface applications involving SMPTE 259M and other data standards.

### DESCRIPTION

The GS9025 provides automatic cable equalization and high performance clock and data recovery for serial digital signals. The GS9025 receives either single-ended or differential serial digital data and outputs differential clock and retimed data signals at PECL levels (800mV). The on-board cable equalizer provides up to 40dB of gain at 200MHz which typically results in equalization of greater than 350m of high quality cable at 270Mb/s.

The GS9025 operates in either auto or manual data rate selection mode. In both modes, the GS9025 requires only one external resistor to set the VCO centre frequency and provides adjustment free operation.

The GS9025 has dedicated pins to indicate signal strength/carrier detect, LOCK and data rate. Optional external resistors allow the carrier detect threshold level to be customized to the user's requirement. In addition, the GS9025 provides an 'Output Eye Monitor' (OEM) which allows the verification of signal integrity after equalization, prior to reslicing. The serial clock outputs can be disabled to reduce power consumption. The GS9025 operates from a single +5 or -5 volt supply.

### ORDERING INFORMATION

PART NUMBER	PACKAGE	TEMPERATURE
GS9025-CQM	44 pin MQFP Tray	0°C to 70°C
GS9025-CTM	44 pin MQFP Tape	0°C to 70°C

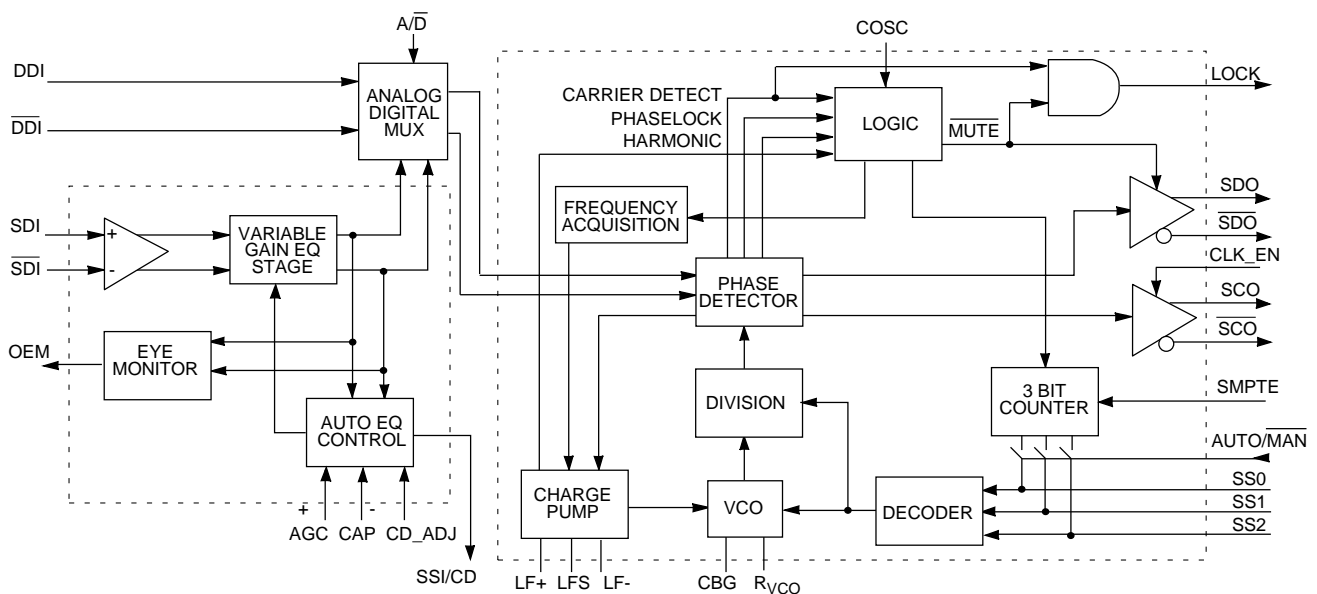

**BLOCK DIAGRAM**

**ABSOLUTE MAXIMUM RATINGS**

PARAMETER	VALUE
Supply Voltage ( $V_S$ )	5.5V
Input Voltage Range (any input)	$V_{CC}+0.5$ to $V_{EE}-0.5V$
Operating Temperature Range	$0^{\circ}C \leq T_A \leq 70^{\circ}C$
Storage Temperature Range	$-65^{\circ}C \leq T_S \leq 150^{\circ}C$
Lead Temperature (soldering, 10 sec)	260°C

**DC ELECTRICAL CHARACTERISTICS**

$V_{CC} = 5.0V$ ,  $V_{EE} = 0V$ ,  $T_A = 0^{\circ}C$  to  $70^{\circ}C$  unless otherwise shown.

PARAMETER	SYMBOL	CONDITIONS	MIN	TYP	MAX	UNITS	NOTES	TEST LEVEL
Supply Voltage	$V_{CC}$		4.75	5.0	5.25	V		1
Supply Current	$I_S$	CLK_EN = 0	-	115	-	mA		1
		CLK_EN = 1	-	125	-	mA		1
		CLK_EN = 0, OEM active	-	135	-	mA		1
		CLK_EN = 1, OEM active	-	145	-	mA		1
SDI/ $\overline{SDI}$ Common Mode Voltage			-	2.5	-	V		1
DDI/ $\overline{DDI}$ Common Mode Input Voltage Range			$V_{EE}+(V_{DIFF}/2)$	0.4 to 4.6	$V_{CC}-(V_{DIFF}/2)$	V	1	1
DDI/ $\overline{DDI}$ Differential Drive			200	800	2000	mV		1
AGC+/ $\overline{AGC-}$ Common Mode Voltage			-	2.7	-	V		1
OEM Bias Potential			-	4.5	-	V		
SSI/CD Output Current		$V_{SSI/CD} = 2.4V$	-	+120	-	$\mu A$		3
		$V_{SSI/CD} = 0.4V$ (Muted)	-	-1.0	-	mA		
AUTO/ $\overline{MAN}$ , SMPTE, SS[2:0] Input Voltage	High		2.0	-	-	V	3	1
	Low		-	-	0.8	V		
CLK_EN Input Voltage	High		2.5	-	-	V		1
	Low		-	-	0.8	V		
LOCK Output Sink Current			500	-	-	$\mu A$	4	1
SS[2:0] Output Voltage	High		4.4	4.7	-	V	3	1
	Low		-	0.2	0.4	V		
SS[2:0] Source Current		Auto Mode	180	300	-	$\mu A$	3	1

**DC ELECTRICAL CHARACTERISTICS (Continued)**

V<sub>CC</sub> = 5.0V, V<sub>EE</sub> = 0V, T<sub>A</sub> = 0°C to 70°C unless otherwise shown.

PARAMETER	SYMBOL	CONDITIONS	MIN	TYP	MAX	UNITS	NOTES	TEST LEVEL
SS[2:0] Sink Current		Auto Mode	0.6	1	-	mA	3	1
SS[2:0] Source Current		Manual Mode	-	-	0	µA	3	1
SS[2:0] Sink Current		Manual Mode	-	0.8	5	µA	3	1

**NOTES**

- V<sub>DIFF</sub> is the differential input signal swing.
- See DESCRIPTION.
- Pins SS[2:0] are outputs in AUTO mode and inputs in MANUAL mode.
- LOCK is an open collector output and requires an external pullup resistor.

**TEST LEVELS**

- 100% tested at 25°C.
- Guaranteed by design.
- Inferred or correlated value.

**AC ELECTRICAL CHARACTERISTICS**

V<sub>CC</sub> = 5.0V, V<sub>EE</sub> = 0V, T<sub>A</sub> = 0°C to 70°C unless otherwise shown. R<sub>LF</sub> = 1kΩ, C<sub>LF1</sub> = 15nF, C<sub>LF2</sub> = 5.6pF

PARAMETER	SYMBOL	CONDITIONS	MIN	TYP	MAX	UNITS	NOTES	TEST LEVELS
Data Rate			143	-	540	Mb/s		1
Maximum Equalizer Gain		at 200MHz	-	40	-	dB		
Additive Jitter	t <sub>j</sub>	270Mb/s, 300m	-	300	-	ps p-p	see Figs 7-11	1
		540Mb/s, 100m	-	275	-	ps p-p		
Jitter Transfer Function Peaking			-	-	0.1	dB		2
Frequency Drift when PLL loses lock				-	±15	%		2
Lock Time Synchronous Switch		t <sub>SWITCH</sub> < 0.5µs, 270Mb/s	-	1	-	µs	1	2
		0.5µs < t <sub>SWITCH</sub> < 10ms	-	1	-	ms		
		t <sub>SWITCH</sub> > 10ms	-	4	-	ms		
Lock Time Asynchronous Switch			-	10	-	ms	2	2
SDO/SDO, SCO/SCO Output Signal Swing		75Ω DC Load	600	800	1000	mVp-p	3	1
SDO to SCO Synchronization			-200	0	200	ps		2
SDO/SDO, SCO/SCO Rise & Fall Times		20 - 80%, T <sub>A</sub> = 25°C	200	300	400	ps		2

**NOTES**

- Synchronous switching refers to switching the input data from one source to another source which is at the same data rate (ie: line 10 switching for component NTSC).
- Asynchronous switching refers to switching the input data from one source to another source which is at a different data rate.
- Assuming 75Ω pullup resistors on SDO/SDO and SCO/SCO.

**TEST LEVELS**

- 100% tested at 25°C.
- Guaranteed by design.
- Inferred or correlated value.
- Evaluated using test setup Figure 1.

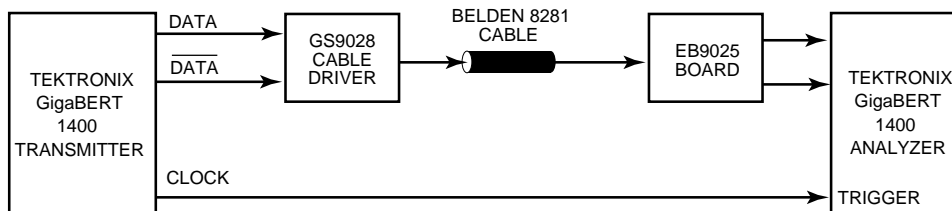
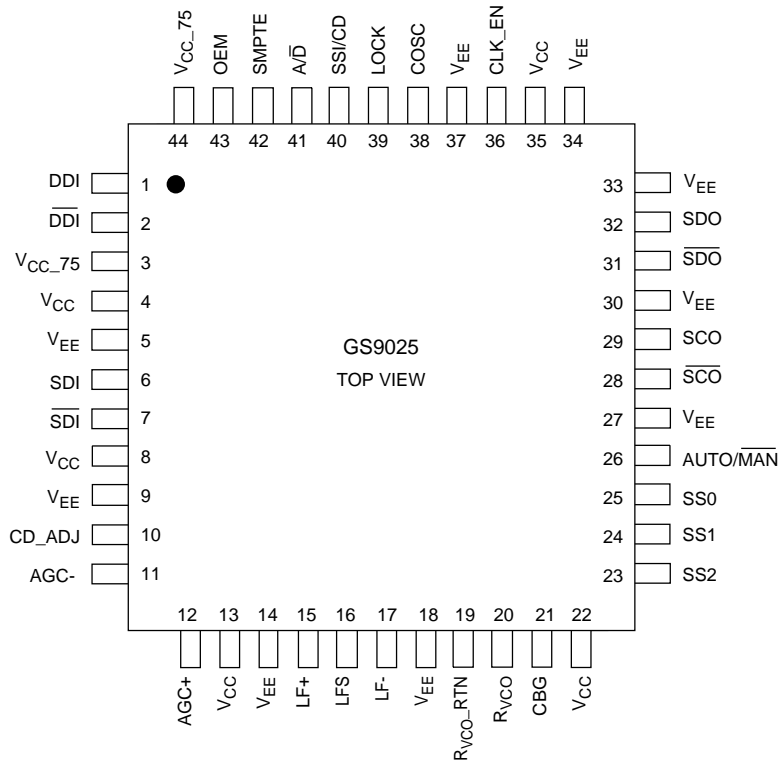

Fig. 1 Test Setup for Figures 6 - 11

**PIN CONNECTIONS**



**PIN DESCRIPTIONS**

NUMBER	SYMBOL	TYPE	DESCRIPTION
1, 2	DDI/ $\overline{\text{DDI}}$	I	Digital data inputs (Differential ECL/PECL).
3, 44	V <sub>CC-75</sub>	I	Power supply connection for internal 75Ω pullup resistors connected to DDI/ $\overline{\text{DDI}}$ .
4, 8, 13, 22, 35	V <sub>CC</sub>	I	Most positive power supply connection.
5, 9, 14, 18, 27, 30, 33, 34, 37	V <sub>EE</sub>	I	Most negative power supply connection.
6, 7	SDI/ $\overline{\text{SDI}}$	I	Differential analog data inputs.
10	CD_ADJ	I	Carrier detect threshold adjust.
11, 12	AGC-, AGC+	I	External AGC capacitor.
15	LF+	I	Loop filter component connection.
16	LFS	I	Loop filter component connection.
17	LF-	I	Loop filter component connection.
19	R <sub>VCO-RTN</sub>	I	Frequency setting resistor return connection.
20	R <sub>VCO</sub>	I	Frequency setting resistor connection.
21	CBG	I	Internal bandgap voltage filter capacitor.
23, 24, 25	SS[2:0]	I/O	Data rate indication (auto mode) or data rate select (manual mode). TTL/CMOS compatible I/O. In auto mode these pins can be left unconnected.
26	AUTO/ $\overline{\text{MAN}}$	I	Auto or manual mode select. TTL/CMOS compatible input.

**PIN DESCRIPTIONS (Continued)**

NUMBER	SYMBOL	TYPE	DESCRIPTION
28, 29	$\overline{\text{SCO}}/\text{SCO}$	O	Serial clock output. $\overline{\text{SCO}}/\text{SCO}$ are differential current mode outputs and require external 75 $\Omega$ pullup resistors.
31, 32	$\overline{\text{SDO}}/\text{SDO}$	O	Equalized and reclocked serial digital data outputs. $\overline{\text{SDO}}/\text{SDO}$ are differential current mode outputs and require external 75 $\Omega$ pullup resistors.
36	CLK_EN	I	Clock enable. When HIGH, the serial clock outputs are enabled.
38	COSC	I	Timing control capacitor for internal system clock.
39	LOCK	O	Lock indication. When HIGH, the GS9025 is locked. LOCK is an open collector output and requires an external 10k $\Omega$ pullup resistor.
40	SSI/CD	O	Signal strength indicator/Carrier detect.
41	A/ $\overline{\text{D}}$	I	Analog/Digital select.
42	SMPTE	I	SMPTE/Other data rate select. TTL/CMOS compatible input.
43	OEM	O	Output 'Eye' monitor. OEM is a single ended current mode output and requires an external 50 $\Omega$ pullup resistor.

**TYPICAL PERFORMANCE CURVES** ( $V_S = 5V$ ,  $T_A = 25^\circ C$  unless otherwise shown)

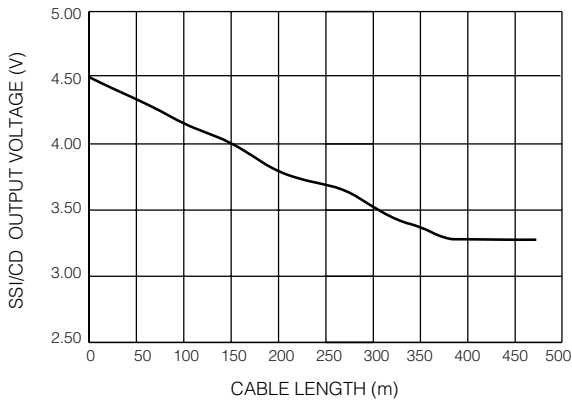

Fig. 2 SSI/CD Voltage vs. Cable Length (Belden 8281)(CD\_ADJ = 0V)

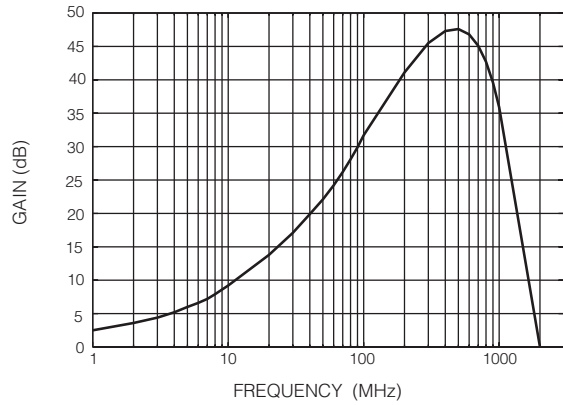

Fig. 3 Equalizer Gain vs. Frequency

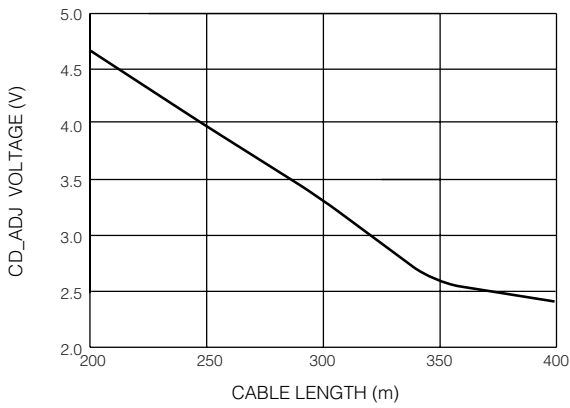

Fig. 4 Carrier Detect Adjust Voltage Threshold Characteristics

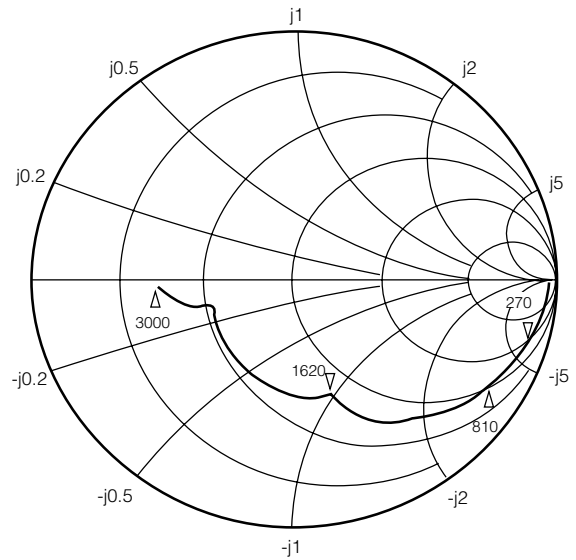

Fig. 5 Input Impedance

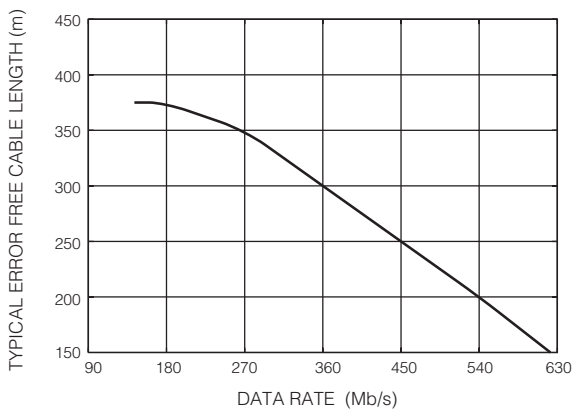

Fig. 6 Error Free Cable Length vs. Data Rate

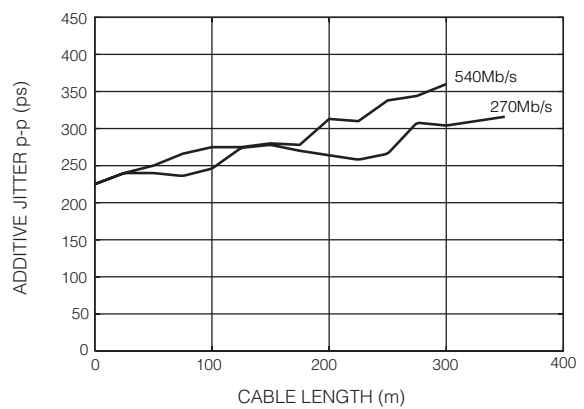

Fig. 7 Additive Jitter vs. Input Cable Length (Belden 8281)

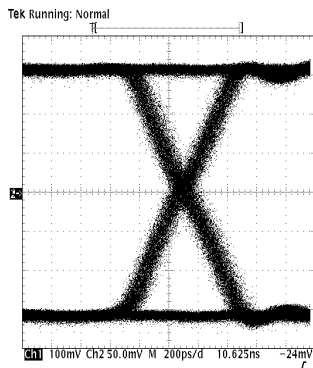

Fig. 8 Output Jitter (143Mb/s, 300m)

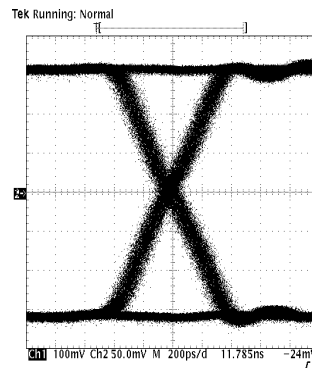

Fig. 9 Output Jitter (270Mb/s, 300m)

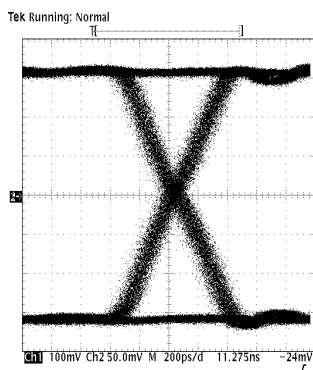

Fig. 10 Output Jitter (360Mb/s, 300m)

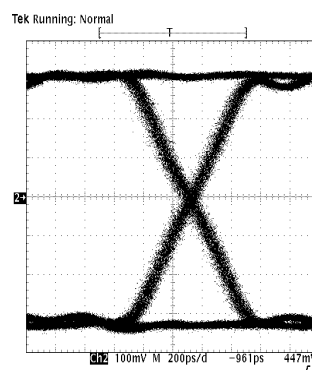

Fig. 11 Output Jitter (540Mb/s, 100m)

**DETAILED DESCRIPTION**

The GS9025 Serial Digital Receiver is a bipolar integrated circuit containing a built-in cable equalizer and reclocker.

Serial digital signals are applied to either the analog SDI/ $\overline{\text{SDI}}$  or digital DDI/ $\overline{\text{DDI}}$  inputs. Signals applied to the SDI/ $\overline{\text{SDI}}$  inputs are equalized and then passed to a multiplexer. Signals applied to the DDI/ $\overline{\text{DDI}}$  inputs bypass the equalizer and go directly to the multiplexer. The analog/digital select pin (A/ $\overline{\text{D}}$ ) determines which signal is then passed to the reclocker.

Packaged in a 44 pin MQFP, the receiver operates from a single 5V supply to data rates of 540Mb/s. Typical power consumption is 575mW.

**1. CABLE EQUALIZER**

The automatic cable equalizer is designed to equalize serial digital data signals between 30Mb/s and 540Mb/s.

The serial data signal is connected to the input pins (SDI/ $\overline{\text{SDI}}$ ) either differentially or single ended. The input signal passes through a variable gain equalizing stage whose frequency response closely matches the inverse cable loss characteristic. In addition, the variation of the frequency response with control voltage imitates the

variation of the inverse cable loss characteristic with cable length. The gain stage provides up to 40dB of gain at 200MHz which typically results in equalization of greater than 350m at 270Mb/s of Belden 8281 cable.

The edge energy of the equalized signal is monitored by a detector circuit which produces an error signal corresponding to the difference between the desired edge energy and the actual edge energy. This error signal is integrated by an external differential AGC filter capacitor (AGC+/ $\overline{\text{AGC-}}$ ) providing a steady control voltage for the gain stage. As the frequency response of the gain stage is automatically varied by the application of negative feedback, the edge energy of the equalized signal is kept at a constant level which is representative of the original edge energy at the transmitter.

The equalized signal is DC restored, thereby restoring its logic threshold to its corrective level regardless of shifts due to AC coupling.

## 2. SIGNAL STRENGTH INDICATION/CARRIER DETECT

The GS9025 incorporates an analog signal strength indicator/carrier detect (SSI/CD) output indicating both the presence of a carrier and the amount of equalization applied to the signal. The voltage output of this pin versus cable length (signal strength) is shown in Figures 2 and 12.

With 0m of cable (800mV input signal levels), the SSI/CD output voltage is approximately 4.5V. As the cable length increases, the SSI/CD voltage decreases linearly providing accurate correlation between the SSI/CD voltage and cable length.

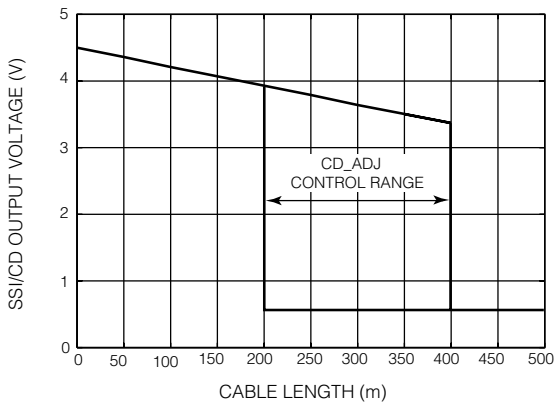

Fig. 12

When the signal strength decreases to the level set at the "Carrier Detect Threshold Adjust" pin, the SSI/CD voltage goes to a logic "0" state (0.8 V) and can be used to drive other TTL/CMOS compatible logic inputs. In addition, when loss of carrier is detected the  $\overline{\text{SDO}}$ /SDO outputs are muted (set to a known static state).

## 3. CARRIER DETECT THRESHOLD ADJUST

This feature has been designed for use in applications such as routers where signal crosstalk and circuit noise cause the equalizer to output erroneous data when no input signal is present. The use of a Carrier Detect function with a fixed internal reference does not solve this problem since the signal to noise ratio on the circuit board could be significantly less than the default signal detection level set by the on chip reference. To alleviate this problem, the GS9025 provides a user adjustable threshold to meet the unique conditions that exist in each user's application. Override and internal default settings have also been provided to give the user total flexibility.

The threshold level at which loss of carrier is detected is adjustable via external resistors at the CD\_ADJ pin. The control voltage at the CD\_ADJ pin is set by a simple resistor divider circuit (see *Typical Application Circuit*). The threshold level is adjustable from 200m to 350m. By default (no external resistors), the threshold is typically 320m. In

noisy environments, it is not recommended to leave this pin floating. Connecting this pin to  $V_{EE}$  disables the  $\overline{\text{SDO}}$ /SDO muting function and allows for maximum possible cable length equalization.

## 4. OUTPUT EYE MONITOR

The GS9025 also provides an 'Output Eye Monitor' (OEM) which allows the verification of signal integrity after equalization, prior to reslicing. The OEM pin is an open collector current output that requires an external 50 $\Omega$  pullup resistor. When the pullup resistor is not used, the OEM block is disabled and the internal OEM circuit is powered down. The OEM provides a 100mVp-p signal when driving a 50 $\Omega$  oscilloscope input.

## 5. RECLOCKER

The reclocker receives a differential serial data stream from the internal multiplexer. It locks an internal clock to the incoming data and outputs the differential PECL retimed data signal and recovered clock on outputs  $\overline{\text{SDO}}$ /SDO and  $\overline{\text{SCO}}$ /SCO, respectively. The timing between the output and clock signals is shown below.

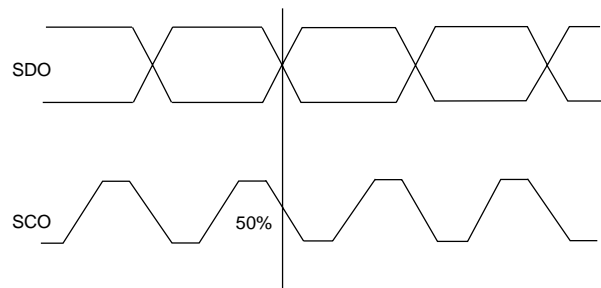

Fig. 13

The reclocker contains four main functional blocks: the Phase Locked Loop, Frequency Acquisition, Logic Circuit, and Auto/Manual Data Rate Select.

### 5.1. Phase Locked Loop (PLL)

The Phase Locked Loop locks the internal PLL clock to the incoming data rate. A simplified block diagram of the PLL is shown below. The main components are the VCO, the phase detector, the charge pump, and the loop filter.



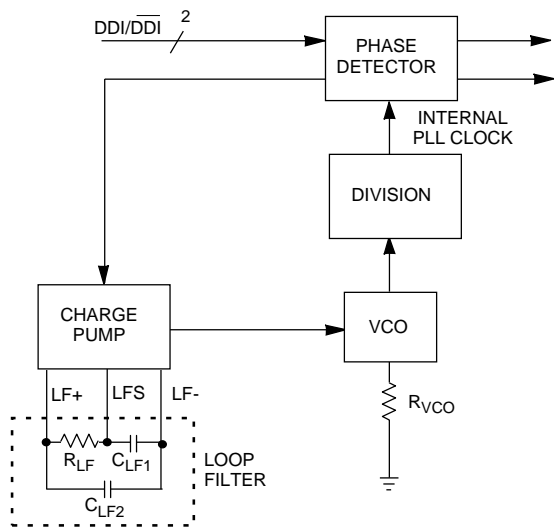

Fig. 14

### 5.1.1. VCO

The VCO is a differential low phase noise, factory trimmed design that provides increased immunity to PCB noise and precise control of the VCO center frequency. The VCO operates between 30 and 540Mb/s and has a pull range of  $\pm 15\%$  about the center frequency. A single low impedance external resistor,  $R_{VCO}$ , sets the VCO center frequency (see Figure 15). The low impedance  $R_{VCO}$  minimizes thermal noise and reduces the PLL's sensitivity to PCB noise.

For a given  $R_{VCO}$  value, the VCO can oscillate at one of two frequencies. When  $SMPTE = SS0 = \text{logic } 1$ , the VCO center frequency corresponds to the  $f_L$  curve. For all other  $SMPTE/SS0$  combinations, the VCO center frequency corresponds to the  $f_H$  curve ( $f_H$  is approximately  $1.5 \times f_L$ ).

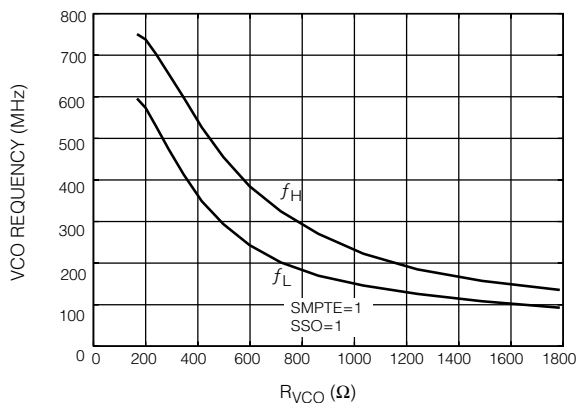

Fig. 15

The recommended  $R_{VCO}$  value for auto rate SMPTE 259M applications is  $365\Omega$ .

The VCO and an internal divider generate the PLL clock. Divider moduli of 1, 2, and 4 allow the PLL to lock to data rates from 143Mb/s to 540Mb/s. The divider modulus is set by the  $AUTO/MAN$ ,  $SMPTE$ , and  $SS[2:0]$  pins (see *Auto/Manual Data Rate Select* section for further details). In addition, a manually selectable modulus 8 divider allows operation at data rates as low as 30Mb/s.

### 5.1.2. Phase Detector

The phase detector compares the phase of the PLL clock with the phase of the incoming data signal and generates error correcting timing pulses. The phase detector design provides a linear transfer function between the input phase and output timing pulses maximizing the input jitter tolerance of the PLL.

### 5.1.3. Charge Pump

The charge pump takes the phase detector output timing pulses and creates a charge packet that is proportional to the system phase error. A unique differential charge pump design insures that the output phase does not drift when data transitions are sparse. This makes the GS9025 ideal for SMPTE 259M applications where pathological signals have data transition densities of 0.05.

### 5.1.4. Loop Filter

The loop filter integrates the charge pump packets and produces a VCO control voltage. The loop filter is comprised of three external components which are connected to pins  $LF+$ ,  $LFS$ , and  $LF-$ . The loop filter design is fully differential giving the GS9025 increased immunity to PCB board noise.

The loop filter components are critical in determining the loop bandwidth and damping of the PLL. Choosing these component values is discussed in detail in the PLL DESIGN GUIDELINES section. Recommended values for SMPTE259M applications are shown in the Typical Application Circuit.

## 5.2. Frequency Acquisition

The core PLL is able to lock if the incoming data rate and the PLL clock frequency are within the PLL capture range (which is slightly larger than the loop bandwidth). To assist the PLL to lock to data rates outside of the capture range, the GS9025 uses a frequency acquisition circuit.

The frequency acquisition circuit sweeps the VCO control voltage such that the VCO frequency changes from  $-10\%$  to  $+10\%$  of the center frequency. Figure 16 shows a typical sweep waveform.

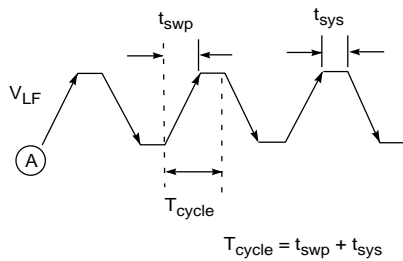

Fig. 16

The VCO frequency starts at point A and sweeps up attempting to lock. If lock is not established during the up sweep, the VCO is then swept down. The system is designed such that the probability of locking within one cycle period is greater than 0.999. If the system does not lock within one cycle period, it will attempt to lock in the subsequent cycle. In manual mode, the divider modulus is fixed for all cycles. In auto mode, each subsequent cycle is based on a different divider moduli as determined by the internal 3-bit counter.

The average sweep time,  $t_{swp}$ , is determined by the loop filter component,  $C_{LF1}$ , and the charge pump current,  $I_{CP}$ :

$$t_{swp} = \frac{4 C_{LF1}}{3 I_{CP}}$$

The nominal sweep time is approximately 121 $\mu$ s when  $C_{LF1} = 15$ nF and  $I_{CP} = 165\mu$ A ( $R_{VCO} = 365\Omega$ ).

An internal system clock determines  $t_{sys}$  (see the *Logic Circuit* section).

### 5.3. Logic Circuit

The GS9025 is controlled by a finite state logic circuit which is clocked by an asynchronous system clock. That is, the system clock is completely independent of the incoming data rate. The system clock runs at low frequencies, relative to the incoming data rate, and thus reduces interference to the PLL. The period of the system clock is set by the COSC capacitor and is:

$$t_{sys} = 9.6 \times 10^4 \times \text{COSC} \text{ [seconds]}$$

The recommended value for  $t_{sys}$  is 450 $\mu$ s (COSC = 4.7nF)

### 5.4. Auto/Manual Data Rate Select

The GS9025 can operate in either auto or manual data rate select mode. The mode of operation is selected by a single input pin ( $\overline{\text{AUTO/MAN}}$ ).

#### 5.4.1. Auto Mode ( $\overline{\text{AUTO/MAN}} = 1$ )

In auto mode, the GS9025 uses a 3-bit counter to automatically cycle through five (SMPTE=1) or three (SMPTE=0) different divider moduli as it attempts to acquire lock. In this mode, the SS[2:0] pins are outputs and indicate the current value of the divider moduli according to the table below. Note that for SMPTE = 0 and divider moduli of 2 and 4, the PLL can correctly lock for two values of SS[2:0].

TABLE 1

AUTO/MAN = 1 (AUTO MODE) $f_H, f_L$ = VCO center frequency as per figure 15.			
SMPTE	SS[2:0]	DIVIDER MODULI	PLL CLOCK
1	000	4	$f_H/4$
1	001	2	$f_L/2$
1	010	2	$f_H/2$
1	011	1	$f_L$
1	100	1	$f_H$
1	101	-	-
1	110	-	-
1	111	-	-
0	000	4	$f_H/4$
0	001	4	$f_H/4$
0	010	2	$f_H/2$
0	011	2	$f_H/2$
0	100	1	$f_H$
0	101	-	-
0	110	-	-
0	111	-	-

#### 5.4.2. Manual Mode ( $\overline{\text{AUTO/MAN}} = 0$ )

In manual mode, the GS9025 divider moduli is fixed. In this mode, the SS[2:0] pins are inputs and set the divider moduli according to Table 2.

## 6. LOCKING

The GS9025 indicates lock when three conditions are satisfied:

1. input data is detected
2. the incoming data signal and the PLL clock are phase locked
3. the system is not locked to a harmonic

TABLE 2

AUTO/ $\overline{\text{MAN}} = 1$ (MANUAL MODE) $f_H, f_L = \text{VCO center frequency as per figure 15.}$			
SMPTE	SS[2:0]	DIVIDER MODULI	PLL CLOCK
1	000	4	$f_H/4$
1	001	2	$f_L/2$
1	010	2	$f_H/2$
1	011	1	$f_L$
1	100	1	$f_H$
1	101	8	$f_L/8$
1	110	8	$f_H/8$
1	111	-	-
0	000	4	$f_H/4$
0	001	4	$f_H/4$
0	010	2	$f_H/2$
0	011	2	$f_H/2$
0	100	1	$f_H$
0	101	1	$f_H$
0	110	8	$f_H/8$
0	111	-	-

The GS9025 defines the presence of input data when at least one data transition occurs every  $1\mu\text{s}$ .

The GS9025 assumes that it is NOT locked to a harmonic if the pattern '101' or '010' (in the relocked data stream) occurs at least once every  $t_{\text{sys}}/3$  seconds. Using the recommended component values, this corresponds to approximately  $150\mu\text{s}$ . (In an harmonically locked system, all bit cells are double clocked and the above patterns become '110011' and '001100', respectively.)

**7. LOCK TIME**

The lock time of the GS9025 depends on whether the input data is switching synchronously or asynchronously. Synchronous switching refers to the case where the input data is changed from one source to another source which is at the same data rate (but different phase). Asynchronous switching refers to the case where the input data to the GS9025 is changed from one source to another source which is at a different data rate.

When input data to the GS9025 is removed, the GS9025 latches the current state of the counter (divider modulus). Therefore, when data is reapplied, the GS9025 begins the lock procedure at the previous locked data rate. As a result, in synchronous switching applications, the GS9025 locks very quickly. The nominal lock time depends on the switching time and is summarized in the table below:

TABLE 3

SWITCHING TIME	LOCK TIME
$< 0.5\mu\text{s}$	$10\mu\text{s}$
$0.5\mu\text{s} - 10\text{ms}$	$2t_{\text{sys}}$
$> 10\text{ms}$	$2T_{\text{cycle}} + 2t_{\text{sys}}$

In asynchronous switching applications (including power up) the lock time is determined by the frequency acquisition circuit as described above. In manual mode, the frequency acquisition circuit may have to sweep over an entire cycle (depending on initial conditions) to acquire lock resulting in a maximum lock time of  $2T_{\text{cycle}} + 2t_{\text{sys}}$ . In auto tune mode, the maximum lock time is  $6T_{\text{cycle}} + 2t_{\text{sys}}$  since the frequency acquisition circuit may have to cycle through 5 possible counter states (depending on initial conditions) to acquire lock. The nominal value of  $T_{\text{cycle}}$  for the GS9025 operating in a typical SMPTE 259M application is approximately 1.3ms.

The GS9025 has a dedicated LOCK output (pin 39) indicating when the device is locked. It should be noted that in synchronous switching applications where the switching time is less than  $0.5\mu\text{s}$ , the LOCK output will NOT be de-asserted and the data outputs will NOT be muted.

**8. OUTPUT DATA MUTING**

The GS9025 internally mutes the  $\overline{\text{SDO}}$  and  $\text{SDO}$  outputs when the device is not locked. When muted,  $\overline{\text{SDO}}/\text{SDO}$  are latched providing a logic state to the subsequent circuit and avoiding a condition where noise could be amplified and appear as data.

The output data muting timing is shown in Figure 17.

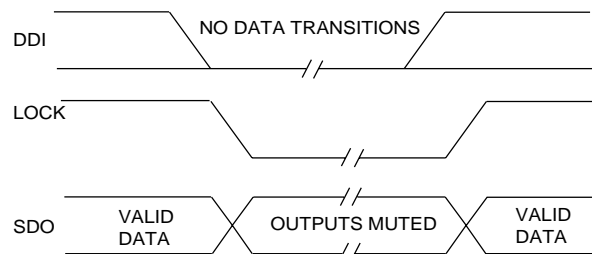

Fig. 17

**9. CLOCK ENABLE**

When CLK\_EN is high, the GS9025  $\overline{\text{SCO}}$ /SCO outputs are enabled. When CLK\_EN is low, the  $\overline{\text{SCO}}$ /SCO outputs are tri-stated and float to V<sub>CC</sub>. Disabling the clock outputs results in a power savings of 10%. It is recommended that the CLK\_EN input be hard wired to the desired state. For applications which do not require the clock output, CLK\_EN should be connected to Ground and the  $\overline{\text{SCO}}$ /SCO outputs should be connected to V<sub>CC</sub>.

**10. STRESSFULL DATA PATTERNS**

All PLL's are susceptible to stressful data patterns which can introduce bit errors in the data stream. PLL's are most sensitive to patterns which have long run lengths of 0's or 1's (low data transition densities for a long period of time). The GS9025 has been designed to operate with low data transition densities such as the SMPTE 259M pathological signal (data transition density = 0.05).

**11. PLL DESIGN GUIDELINES**

The relocking performance of the GS9025 is primarily determined by the PLL. Thus, it is important that the system designer is familiar with the basic PLL design equations.

A model of the GS9025 PLL is shown below. The main components are the phase detector, the VCO, and the external loop filter components.

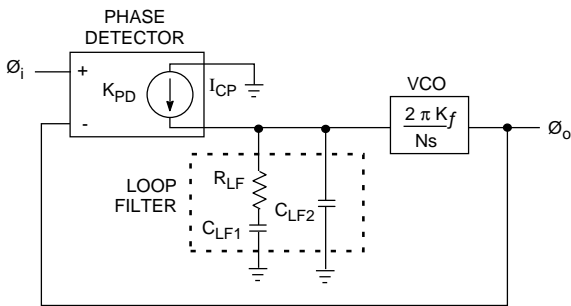

Fig. 18

**11.1. Transfer Function**

The transfer function of the PLL is defined as  $\phi_o/\phi_i$  and can be approximated as:

$$\frac{\phi_o}{\phi_i} = \frac{sC_{LF1}R_{LF} + 1}{\left[ s\left( C_{LF1}R_{LF} - \frac{L}{R_{LF}} \right) + 1 \right] \left[ s^2C_{LF2}L + s\frac{L}{R_{LF}} + 1 \right]}$$

Equation 1

where  $L = \frac{N}{DI_{CP}K_f}$  and

N is the divider modulus

D is the data density (=0.5 for NRZ data)

I<sub>CP</sub> is the charge pump current in Amps

K<sub>f</sub> is the VCO gain in Hz/V

This response has 1 zero ( $w_z$ ) and three poles ( $w_{P1}, w_{BW}, w_{P2}$ ) where:

$$w_z = \frac{1}{C_{LF1}R_{LF}}$$

$$w_{P1} = \frac{1}{C_{LF1}R_{LF} - \frac{L}{R_{LF}}}$$

$$w_{BW} = \frac{R_{LF}}{L}$$

$$w_{P2} = \frac{1}{C_{LF2}R_{LF}}$$

The bode plot for this transfer function is plotted in Figure 19.

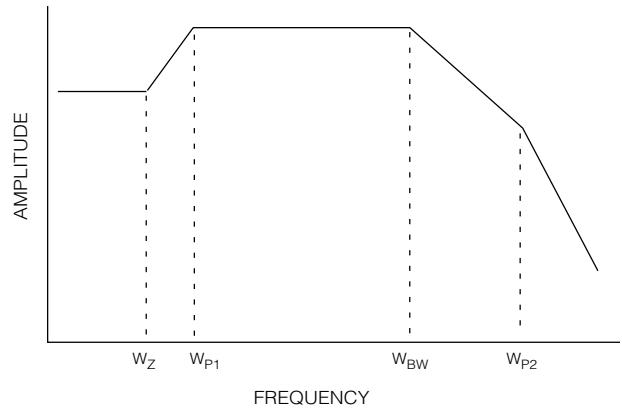

Fig. 19

The 3dB bandwidth of the transfer function is approximately:

$$w_{3dB} = \frac{w_{BW}}{\sqrt{1 - 2\frac{w_{BW}}{w_{P2}} + \frac{(w_{BW}/w_{P2})^2}{1 - 2\frac{w_{BW}}{w_{P2}}}}} \approx \frac{w_{BW}}{0.78}$$

**11.2. Transfer Function Peaking**

There are two causes of peaking in the PLL transfer function given by Equation 1.

The first is quadratic:

$$s^2C_{LF2}L + s\frac{L}{R_{LF}} + 1$$

which has:

$$w_o = \frac{1}{\sqrt{C_{LF2}L}} \quad \text{and} \quad Q = R_{LF}\sqrt{\frac{R_{LF2}}{L}}$$

This response is critically damped for Q = 0.5.

Thus, to avoid peaking:

$$R_{LF} \sqrt{\frac{C_{LF2}}{L}} < \frac{1}{2} \quad \text{or} \quad \frac{1}{R_{LF2} C_{LF2}} \frac{L}{R_{LF}} > 4$$

Therefore,

$$w_{P2} > 4 w_{BW}$$

However, it is desirable to keep  $w_{P2}$  as low as possible to reduce the high frequency content on the loop filter.

The second is the zero-pole combination:

$$\frac{s C_{LF1} R_{LF} + 1}{s \left( C_{LF1} R_{LF} - \frac{1}{R_{LF}} \right) + 1} = \frac{\frac{s}{w_Z} + 1}{\frac{s}{w_{P1}} + 1}$$

This causes lift in the transfer function given by:

$$20 \text{ LOG } \frac{w_{P1}}{w_Z} = 20 \text{ LOG } \frac{1}{1 - \frac{w_Z}{w_{BW}}}$$

To keep peaking to less than 0.05dB:

$$w_Z < 0.0057 w_{BW}$$

### 11.3. Selection of Loop Filter Components

Based on the above analysis, the loop filter components should be selected for a given PLL bandwidth,  $f_{3dB}$ , as follows:

1. Calculate

$$L = \frac{2N}{I_{CP} K_f}$$

where:

$I_{CP}$  is the charge pump current and is a function of the  $R_{VCO}$  resistor and is obtained from Figure 21.

$K_f = 90\text{MHz/V}$  for VCO frequencies corresponding to the  $f_L$  curve.

$K_f = 140\text{MHz/V}$  for VCO frequencies corresponding to the  $f_H$  curve.

$N$  is the divider modulus

( $f_L$ ,  $f_H$  and  $N$  can be obtained from Table 1 or Table 2)

2. Choose  $R_{LF} = 2(3.14)f_{3dB}(0.78)L$
3. Choose  $C_{LF1} = 174L/(R_{LF})^2$
4. Choose  $C_{LF2} = L/4(R_{LF})^2$

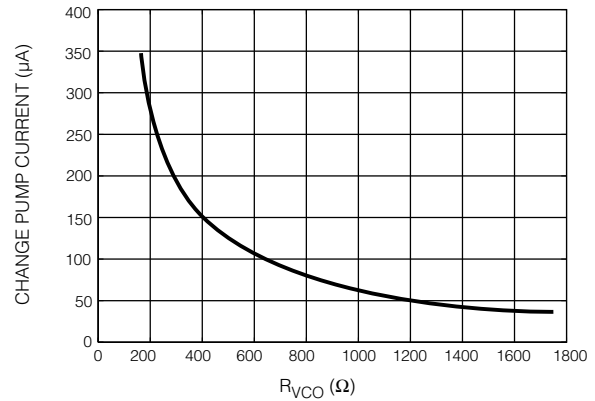
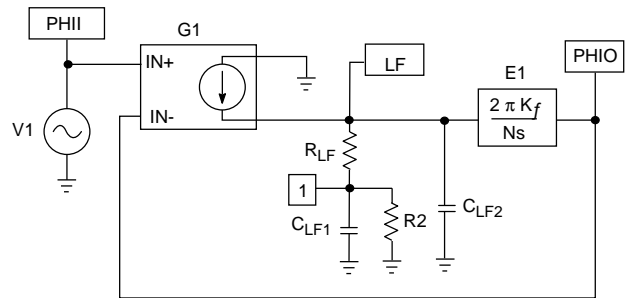

Fig. 20

### 11.4. SPICE Simulations

More detailed analysis of the GS9025 PLL can be done using SPICE. A SPICE model of the PLL is shown below:



NOTE: PHII, PHIO, LF, and 1 are node names in the SPICE netlist.

Fig. 21

The model consists of a voltage controlled current source (G1), the loop filter components ( $R_{LF}$ ,  $C_{LF1}$ , and  $C_{LF2}$ ), a voltage controlled voltage source (E1), and a voltage source (V1). R2 is necessary to create a DC path to ground for Node 1.

V1 is used to generate the input phase waveform. G1 compares the input and output phase waveforms and generates the charge pump current,  $I_{CP}$ . The loop filter components integrate the charge pump current to establish the loop filter voltage. E1 creates the output phase waveform (PHIO) by multiplying the loop filter voltage by the value of the Laplace transform ( $2\pi K_f/Ns$ ).

The net list for the model is given below. The .PARAM statements are used to set values for  $I_{CP}$ ,  $K_f$ ,  $N$ , and  $D$ .  $I_{CP}$  is determined by the  $R_{VCO}$  resistor and is obtained from Figure 20.

```

SPICE NETLIST * GS9025 PLL Model
.PARAM ICP = 165E-6 KF= 90E+6
.PARAM N = 1 D = 0.5
.PARAM PI = 3.14
.IC V(Phio) = 0
.ac dec 30 1k 10meg
RLF 1 LF 1000
CLF1 1 0 15n
CLF2 0 LF 15p
E_LAPLACE1 Phio 0 LAPLACE {V(LF)} {(2*PI*KF)/(N*s)}
G1 0 LF VALUE{D * ICP/(2*pi)*V(Phii, Phio)}
V1 2 0 DC 0V AC 1V
R2 0 1 1g
.END
    
```

**12. I/O DESCRIPTION**

**12.1. High Speed Analog Inputs (SDI/ $\overline{\text{SDI}}$ )**

SDI/ $\overline{\text{SDI}}$  are high impedance inputs which accept differential or single-ended input drive.

Figure 22 shows the recommended interface when a single-ended serial digital signal is used.

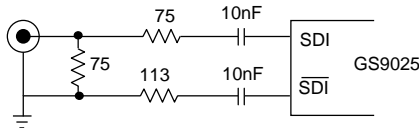

Fig. 22

**12.2. High Speed Digital Inputs (DDI/ $\overline{\text{DDI}}$ )**

DDI/ $\overline{\text{DDI}}$  are high impedance inputs which accept differential or single-ended input drive. Two conditions must be observed when interfacing to these inputs:

1. Input signal amplitudes are between 200 and 2000 mV
2. The common mode input voltage range is as specified in the DC Characteristics table.

Commonly used interface examples are shown in Figures 23 through 25.

Figure 23 illustrates the simplest interface to the GS9025 digital inputs. In this example, the driving device generates the PECL level signals (800mV amplitudes) having a common mode input range between 0.4 and 4.6V. This scheme is recommended when the trace lengths are less than 1in. The value of the resistors depends on the output driver circuitry.

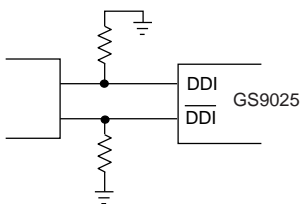

Fig. 23

When trace lengths become greater than 1in, controlled impedance traces should be used. The recommended interface is shown in Figure 25. In this case, a parallel resistor ( $R_{\text{LOAD}}$ ) is placed near the GS9025 inputs to terminate the controlled impedance trace. The value of  $R_{\text{LOAD}}$  should be 2 times the value of the characteristic impedance of the trace. In addition, series resistors,  $R_{\text{SOURCE}}$ , can be placed near the driving chip to serve as source terminations. They should be equal to the value of the trace impedance. Assuming 800mV output swings at the driver,  $R_{\text{LOAD}} = 100\Omega$ ,  $R_{\text{SOURCE}} = 50\Omega$  and  $Z_0 = 50\Omega$ .

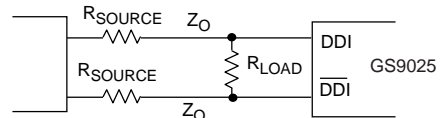

Fig. 24

Figure 25 shows the recommended interface when the GS9025 digital inputs are driven single-endedly. In this case, the input must be AC-coupled and a matching resistor ( $Z_0$ ) must be used.

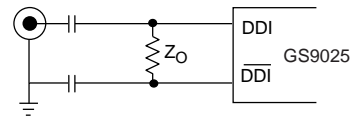

Fig. 25

When the DDI and the  $\overline{\text{DDI}}$  inputs are not used, either pins 44 and 1 or pins 2 and 3 should be connected to  $V_{\text{CC}}$  in order to saturate one input of the differential amplifier.

**12.3. High Speed Outputs ( $\overline{\text{SDO}}$ /SDO and  $\overline{\text{SCO}}$ /SCO)**

$\overline{\text{SDO}}$ /SDO and  $\overline{\text{SCO}}$ /SCO are current mode outputs that require external pullups (see Figure 26). The output signal swings are 800mV when 75 $\Omega$  resistors are used. A diode can be placed between  $V_{\text{CC}}$  and the pullups to shift the signal levels down by approximately 0.7 volts. When the output traces are longer than 1in, controlled impedance traces should be used. The pullup resistors should be placed at the end of the output traces as they terminate the trace in its characteristic impedance (75 $\Omega$ ).

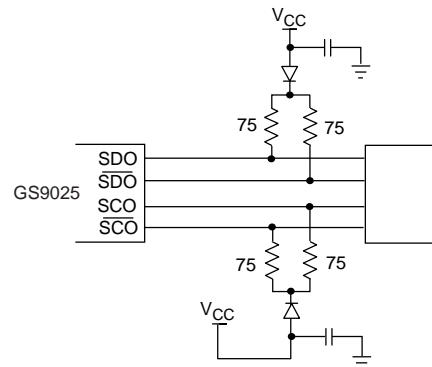
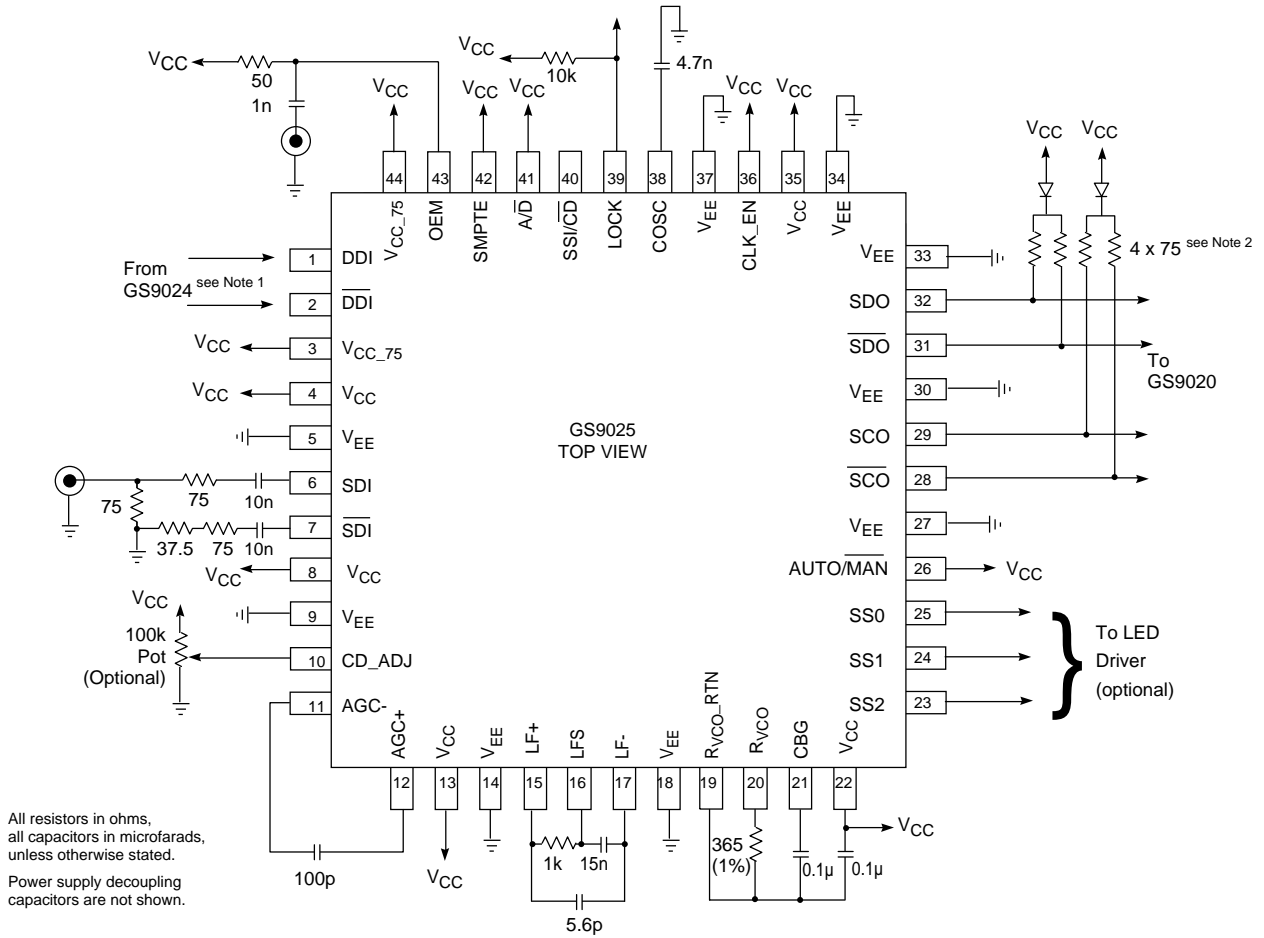

Fig. 26

TYPICAL APPLICATION CIRCUIT



All resistors in ohms, all capacitors in microfarads, unless otherwise stated. Power supply decoupling capacitors are not shown.

- NOTES
1. It is recommended that the DDI/DDI inputs are not driven when the SDI/SDI inputs are being used. This minimizes crosstalk between the DDI/DDI and SDI/SDI inputs and maximizes performance.
  2. These resistors are not needed if the internal pull-up resistors on the GS9020 are used.

TABLE 4:  $R_{VCO} = 365$ ,  $f_H = 540\text{MHz}$ ,  $f_L = 360\text{MHz}$

SMPTE	SS[2:0]	DATA RATE (Mb/s)	LOOP BANDWIDTH
1	000	143	850kHz
1	001	177	1.40MHz
1	010	270	1.70MHz
1	011	360	3.0MHz
1	100	540	4.0MHz

**PACKAGE DIMENSIONS**

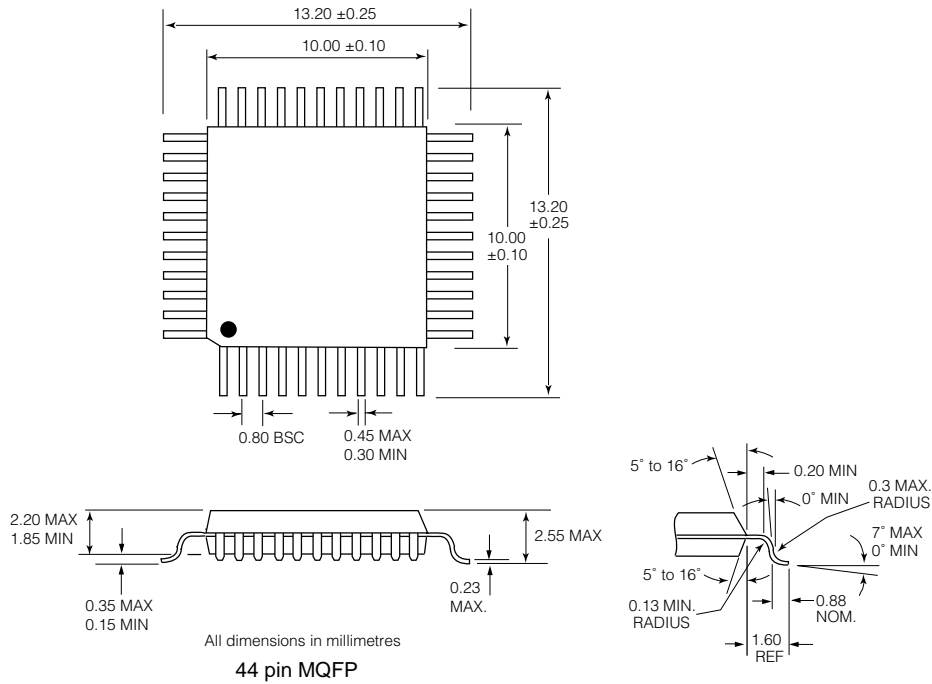

**CAUTION**  
ELECTROSTATIC  
SENSITIVE DEVICES  
DO NOT OPEN PACKAGES OR HANDLE  
EXCEPT AT A STATIC-FREE WORKSTATION

**DOCUMENT IDENTIFICATION**  
PRELIMINARY DATA SHEET  
The product is in a preproduction phase and specifications  
are subject to change.

**REVISION NOTES:**  
Clarified symbols for pin numbers 28, 29, 31, and 32;  
Changed SSI/CD to SSI/CD.  
  
*For latest product information, visit [www.gennum.com](http://www.gennum.com)*

**GENNUM CORPORATION**

MAILING ADDRESS:  
P.O. Box 489, Stn. A, Burlington, Ontario, Canada L7R 3Y3  
Tel. +1 (905) 632-2996 Fax. +1 (905) 632-5946

SHIPPING ADDRESS:  
970 Fraser Drive, Burlington, Ontario, Canada L7L 5P5

**GENNUM JAPAN CORPORATION**

C-101, Miyamae Village, 2-10-42 Miyamae, Suginami-ku  
Tokyo 168-0081, Japan  
Tel. +81 (03) 3334-7700 Fax. +81 (03) 3247-8839

**GENNUM UK LIMITED**

25 Long Garden Walk, Farnham, Surrey, England GU9 7HX  
Tel. +44 (0)1252 747 000 Fax +44 (0)1252 726 523

Gennum Corporation assumes no responsibility for the use of any circuits described herein and makes no representations that they are free from patent infringement.  
© Copyright August 1997 Gennum Corporation. All rights reserved. Printed in Canada.