



FEATURES

- **low & high frequency gain adjustment**
- **adjustable high frequency compression ratio (1:1 to 4:1)**
- **fixed low frequency compression ratio (3:1)**
- **twin average detection™**
- **24dB/octave band split filter**
- **8:1 output compression limiting**
- **notch filter to minimize acoustic feedback**
- **pre & post emphasis circuitry**
- **low level squelch control (1:2 expansion)**
- **multi memory (4)**
- **8 programmable parameters**

thinSTAX™ PACKAGING

Hybrid typical dimensions:

0.200 x 0.128 x 0.060in.
(5.08 x 3.25 x 1.52mm)

DESCRIPTION

The GA3203 programmable hybrid is composed of a DynamEQ®III Wide Dynamic Range Compression signal processor and the GP523 controller memory chip.

The hybrid has 8 programmable parameters including Low Frequency Gain, High Frequency Gain, High Frequency Compression Ratio, Band Split Filter Crossover Frequency, AGC-I Threshold Kneepoint, AGC-O Threshold, Volume Control and Notch Feedback Control.

The DynamEQ®III includes a squelch circuit which attenuates microphone and circuit noise in quiet environments and high gain conditions. It also includes low distortion compression limiting AGC-O, pre and post emphasis circuitry, and an acoustic feedback notch filter.

The GA3203 hybrid code programmed into the GP523 is "4".

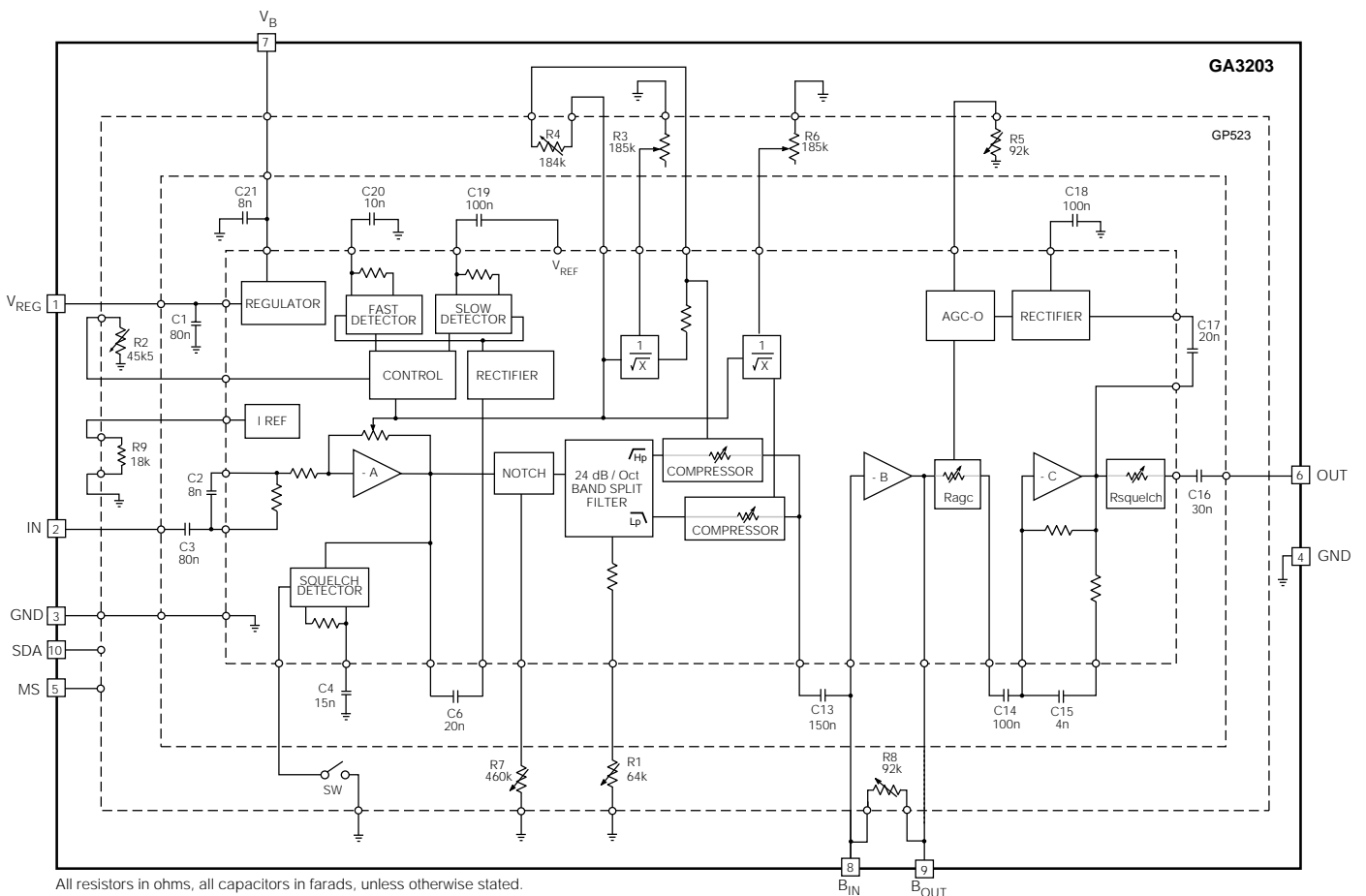

BLOCK DIAGRAM

ABSOLUTE MAXIMUM RATINGS

PARAMETER	VALUE
Supply Voltage	2VDC
Power Dissipation	25mW
Operating Temperature Range	-10°C to 40°C
Storage Temperature Range	-20°C to 70°C

CAUTION
ELECTROSTATIC
SENSITIVE DEVICES
DO NOT OPEN PACKAGES OR HANDLE
EXCEPT AT A STATIC FREE WORKSTATION



PAD CONNECTION

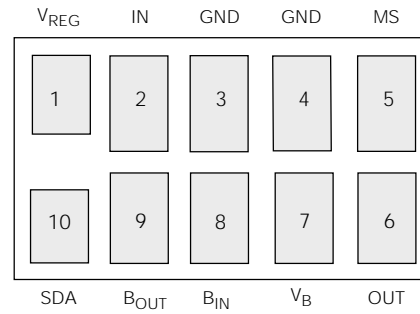

ELECTRICAL CHARACTERISTICS

Conditions: Supply Voltage $V_b = 1.3\text{VDC}$, Frequency = 3kHz, Temperature = 25°C

The programmable parameters are adjusted to the following set values unless otherwise specified:

(FC) R1 - Tap 15; (TH) R2 - Tap 15; (G_{th}) R3 - Tap 0; (CR_{th}) R4 - Tap 15; (MPO) R5 - Tap 4; (G_{LO}) R6 - Tap 15;

(NOTCH) R7 - Tap 24; (VC) R8 - Tap 23; (Squelch) SW - CLOSED (0).

PARAMETER	SYMBOL	CONDITIONS	MIN	TYP	MAX	UNITS
SYSTEM PERFORMANCE						
Hybrid Amplifier Current	I_{AMP}	$V_{IN} = 0\text{V}$, R6 - Tap 0, SW - Open (Squelch Enabled)	315	660	945	μA
Minimum Voltage	V_b		1.1	-	-	V
Regulator Voltage	V_{REG}	$V_{IN} = 0\text{V}$, R6 - Tap 0, $I_{REG} = 30\mu\text{A}$	890	940	1000	mV
Regulator Supply Rejection	PSRR		-	50	-	ratio
System Gain High Frequency	A_{VHIGH}	$V_{IN} = -95\text{dBV}$	48	51	54	dB
System Gain Low Frequency	A_{VLOW}	$V_{IN} = -95\text{dBV}$ @ 1kHz, R1 - Tap 0, R3 - Tap 15, R4 - Tap 0, R6 - Tap 0	43	46	49	dB
Input Referred Noise	IRN		-	3.0	-	μV
Total Harmonic Distortion	THD	$V_{IN} = -40\text{dBV}$ @ 1kHz, R1 - Tap 0, R6 - Tap 0	-	0.5	1	%
THD with Maximum Allowable Input	THD_{MAX}	$V_{IN} = -23\text{dBV}$ @ 1kHz, R1 - Tap 0, R6 - Tap 0	-	1	5	%
AGC-I (Note 1)						
Minimum Compression Knee Point	TK_{LOW}		-93	-89	-85	dBV
Maximum Compression Knee Point	TK_{HI}	R2 - Tap 0	-54	-50	-46	dBV
AGC - I Attack Time	τ_{ATT-I}	$V_{IN} = -65$ to -40dBV , (4dB from final value) $f = 2\text{kHz}$, R1 - Tap 0	4	8	12	ms
AGC - I Release Time	τ_{REL-I}	$V_{IN} = -40$ to -65dBV , (2dB from final value) $f = 2\text{kHz}$, R1 - Tap 0	300	450	600	ms
HIGH PASS (Note 1)						
Max. High Pass Compression Ratio	HP_{CRMAX}	$V_{IN} = -80$ to -60dBV	3.7	4.2	4.7	ratio
Min. High Pass Compression Ratio	HP_{CRMIN}	$V_{IN} = -80$ to -60dBV , R4 - Tap 0	0.8	1	1.2	ratio
Maximum Upper Threshold	HP_{UMAX}		-35	-31	-27	dBV
High Pass Gain Control Range	HP_{RANGE}	$V_{IN} = -95\text{dBV}$, R3 - Tap 0 to Tap 15	41	45	49	dB
LOW PASS (Note 1, R1 - Tap 0, R3 - Tap 15, R4 - Tap 0, R6 - Tap 0, $f = 1\text{kHz}$)						
Low Pass Compression Ratio	LP_{CR}	$V_{IN} = -80$ to -60dBV , R6 - Tap 15	2.5	3	3.5	ratio
Maximum Upper Threshold	LP_{UMAX}		-32	-28	-24	dBV
Low Pass Gain Control Range	LP_{RANGE}	$V_{IN} = -95\text{dBV}$, R6 - Tap 0 to Tap 15	36	40	44	dB

NOTE 1: Measured at output of Stage B

ELECTRICAL CHARACTERISTICS (CONTINUED)

Conditions: Supply Voltage $V_B = 1.3VDC$, Frequency = 3kHz, Temperature = 25°C

The programmable parameters are adjusted to the following set values unless otherwise specified:

(FC) R1 - Tap 15; (TH) R2 - Tap 15; (G_{HP}) R3 - Tap 0; (CR_{HP}) R4 - Tap 15; (MPO) R5 - Tap 4; (G_{LO}) R6 - Tap 15;

(NOTCH) R7 - Tap 24; (VC) R8 - Tap 23; (Squelch) SW - CLOSED (0).

PARAMETER	SYMBOL	CONDITIONS	MIN	TYP	MAX	UNITS
AGC - O (R3 - Tap 15, R4 - Tap 0, R6 - Tap 15)						
Compression Ratio	CR_{AGC-O}	$V_{IN} = -40$ to $-25dBV$, R5 - Tap15	6.7	7.7	8.7	ratio
Maximum Threshold	TH_{MAX}		-34	-31	-28	dBV
Minimum Threshold	TH_{MIN}	R5 - Tap15	-50	-47	-44	dBV
Threshold Range	ΔTH		12	15	18	dB
Attack Time	τ_{AT-O}	$V_{IN} = -50$ to $-25dBV$ (2dB from final value) $f = 2kHz$, R5 - Tap15, R1 - Tap 0	12	18	24	ms
Release Time	τ_{REL-O}	$V_{IN} = -25$ to $-50dBV$ (2dB from final value) $f = 2kHz$, R5 - Tap15, R1 - Tap 0	80	135	200	ms
SQUELCH						
Squelch Expansion Ratio	SQ_{EXP}	$V_{IN} = -95$ to $-92dBV$, SW - Open, R2 - Tap 8	1.8	2.2	3.0	ratio
Squelch Threshold	SQ_{TH}	SW - Open, R2 - Tap 8	-93	-89	-85	dBV
PRE and POST EMPHASIS						
Low Cut Corner Frequency (Pre-Emphasis)	PRE_{3dB}		-	1	-	kHz
Low Boost Corner Frequency (Post-Emphasis)	$POST_{3dB}$		-	1	-	kHz
STATE VARIABLE FILTER						
Minimum Crossover Frequency	FC_{MIN}	R1 - Tap 15	-	0.9	1.4	kHz
Maximum Crossover Frequency	FC_{MAX}	R1 - Tap 0	3	3.9	-	kHz
Nominal Crossover Frequency	FC_{NOM}	R1 - Tap 8	1.3	1.7	2.1	kHz
NOTCH FILTER						
Minimum Notch Frequency	FN_{MIN}	R7 - Tap 23	-	2.2	2.8	kHz
Maximum Notch Frequency	FN_{MAX}	R7 - Tap 0	5	7.5	-	kHz
Nominal Notch Frequency	FN_{NOM}	R7 - Tap 18	1.5	2.3	3.1	kHz
Notch Bandwidth	FN_{BW}	R7 - Tap 23	0.3	0.6	0.9	kHz
Notch Attenuation	FN_{ATTN}	R7 - Tap 23	7	12	17	dB

NOTE 1: Measured at output of Stage B

SUPPORT SOFTWARE

All support software for the GA3203 and the GP523 is available from Gennum's website:

www.gennum.com/hip/software

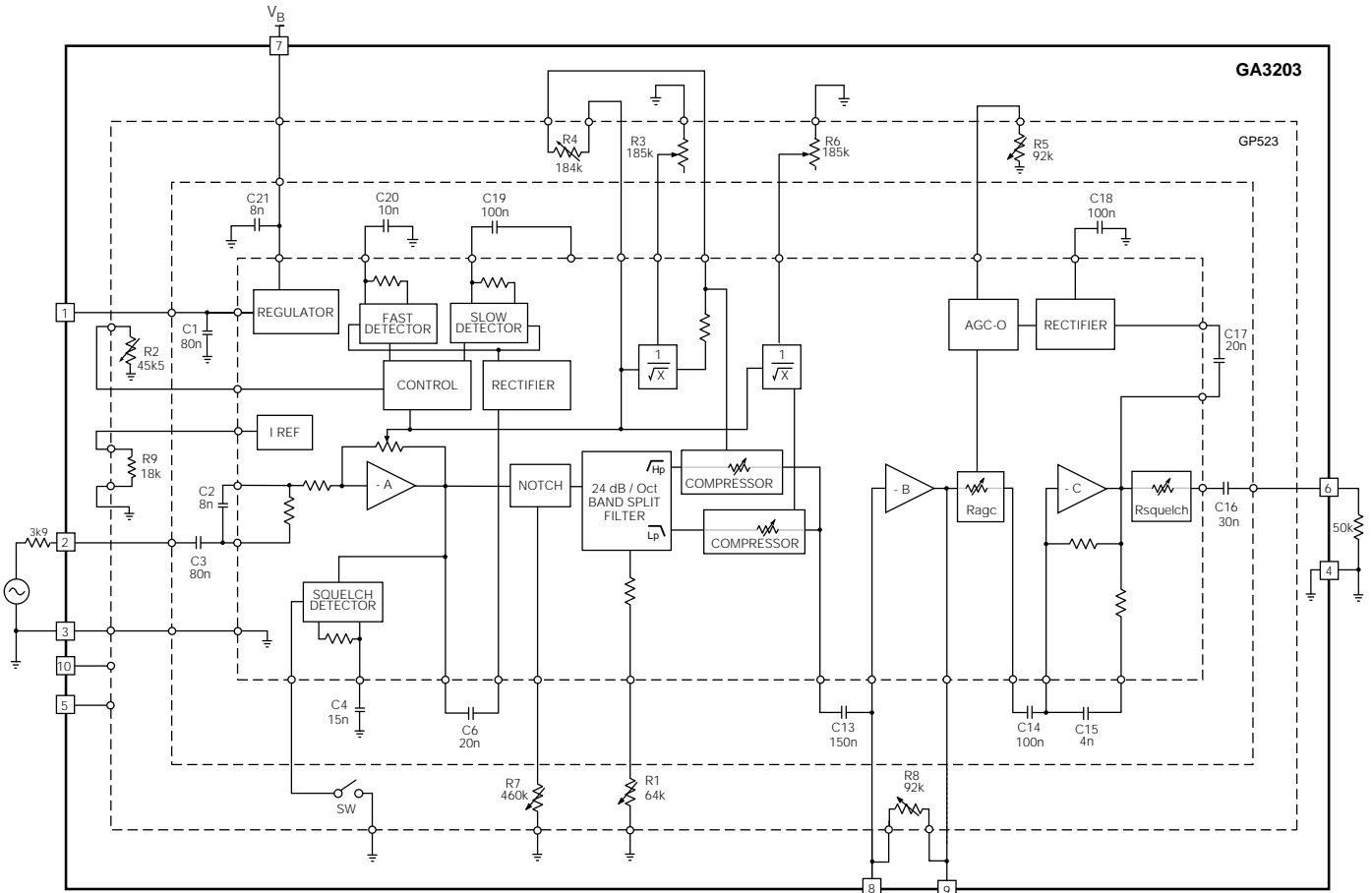

All resistors in ohms, all capacitors in farads, unless otherwise stated.

Fig. 1 Test Circuit

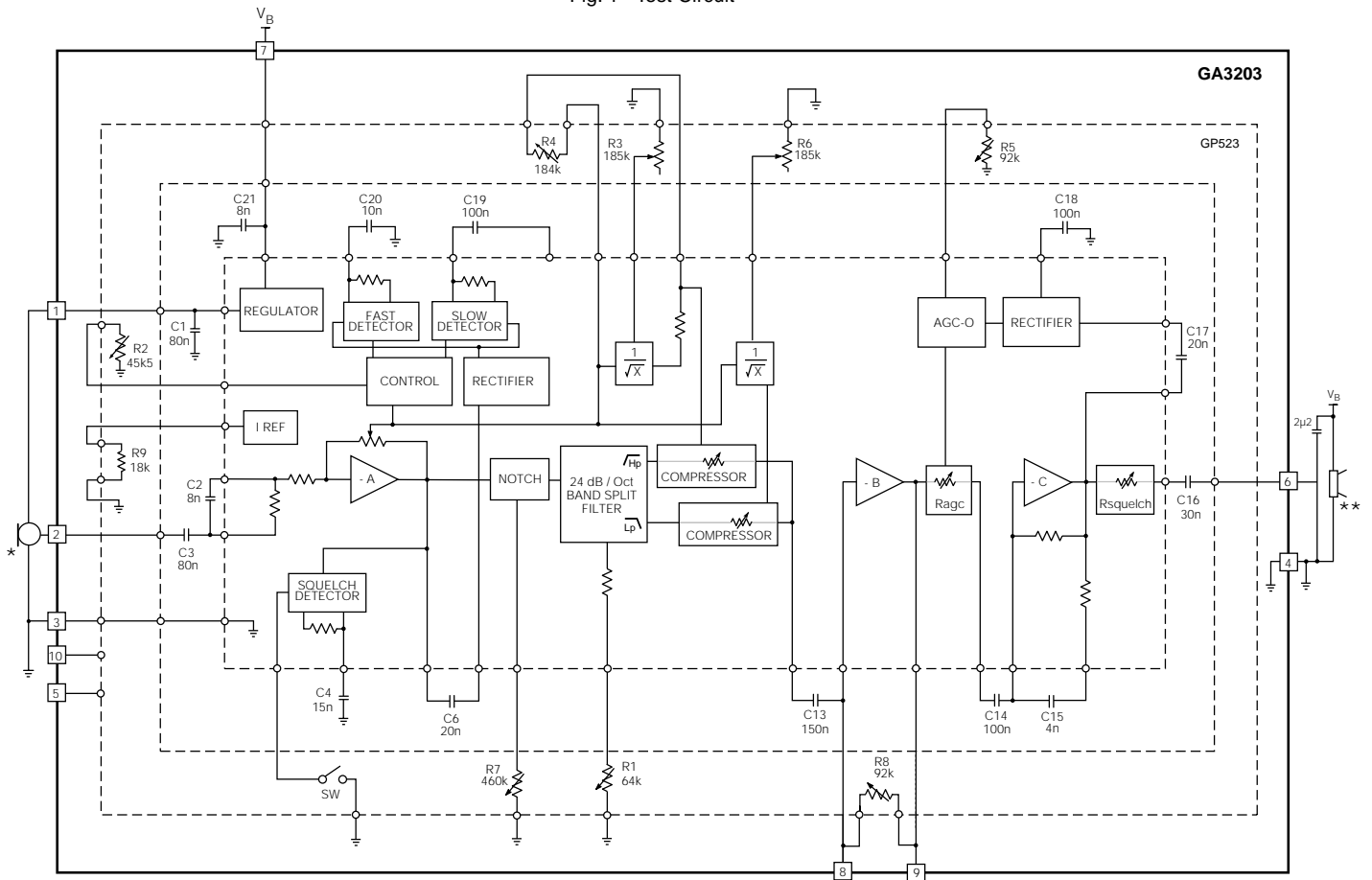

*Any Knowles or Microtronic microphone

**Any Knowles Class D integrated receiver

All resistors in ohms, all capacitors in farads, unless otherwise stated.

Fig. 2 Typical Application circuit

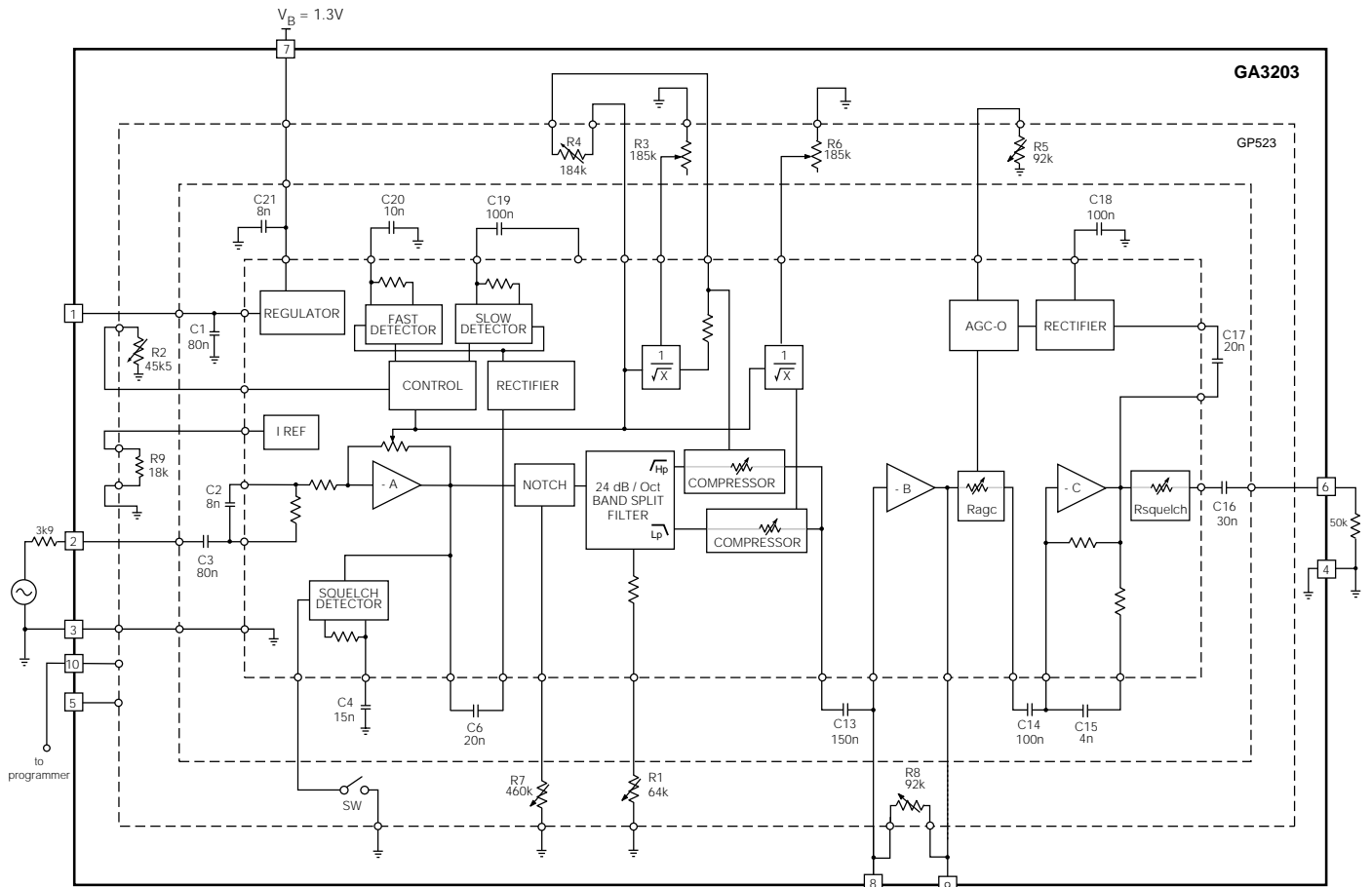

All resistors in ohms, all capacitors in farads, unless otherwise stated.

Fig. 3 Characterization circuit (used to generate typical curves)

TABLE OF DEFAULTS

R1 - Tap 15	R5 - Tap 4
R2 - Tap 15	R6 - Tap 0
R3 - Tap 0	R7 - Tap 24
R4 - Tap 15	R8 - Tap 23
SW - CLOSED	

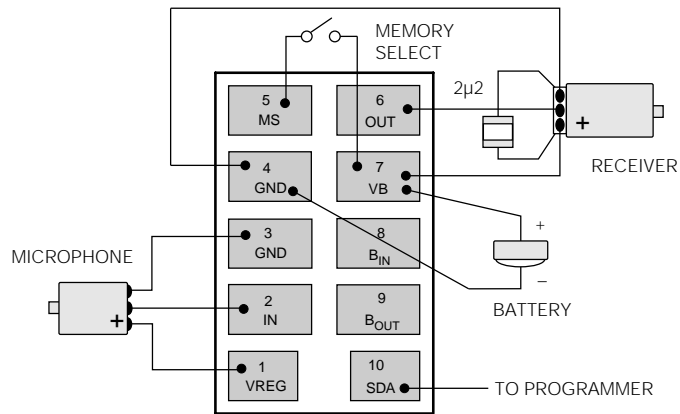

Fig. 4 Typical Assembly Diagram

TYPICAL PERFORMANCE CURVES

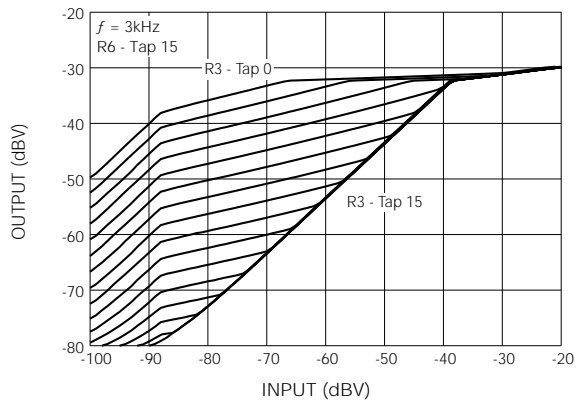

Fig. 5 High Frequency Gain Control
(Tap 0 - 185kΩ, Tap 15 - 0kΩ)

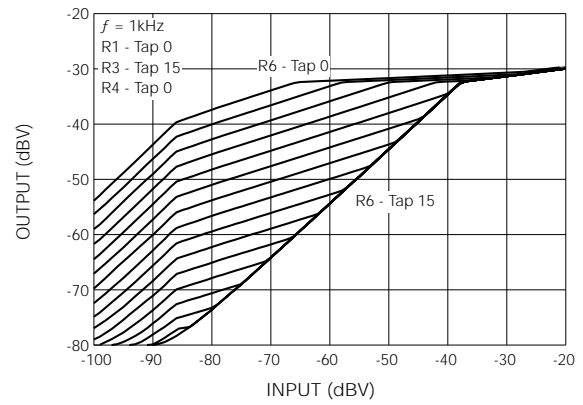

Fig. 6 Low Frequency Gain Control
(Tap 0 - 185kΩ, Tap 15 - 0kΩ)

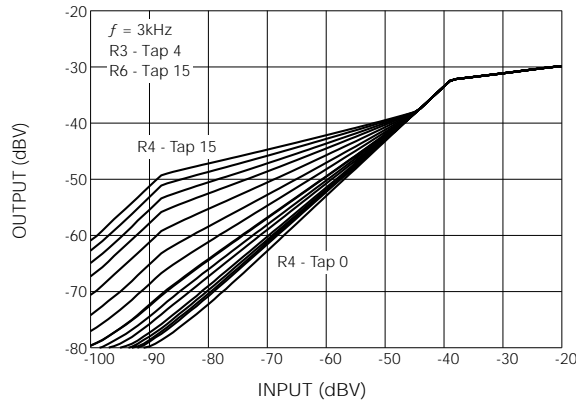

Fig. 7 High Frequency Compression Ratio Control
(Tap 0 - 0kΩ, Tap 15 - 184kΩ)

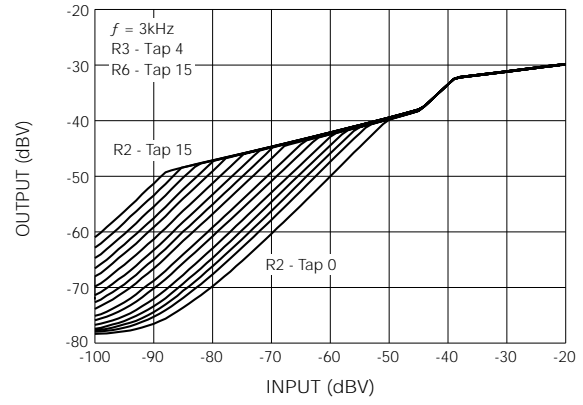

Fig. 8 AGC-I Threshold Control
(Tap 0 - 0kΩ, Tap 15 - 45.5kΩ)

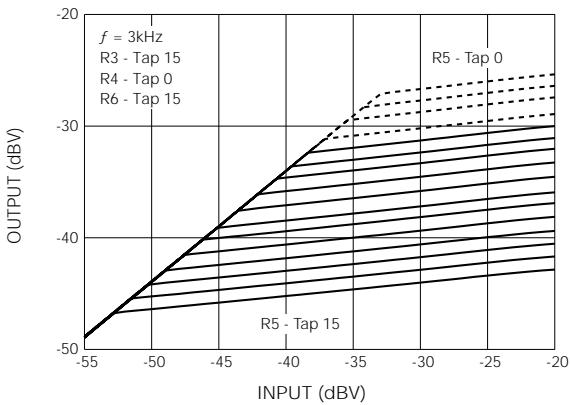

Fig. 9 AGC-O Threshold Control
(Tap 0 - 7.3kΩ, Tap 15 - 92kΩ)

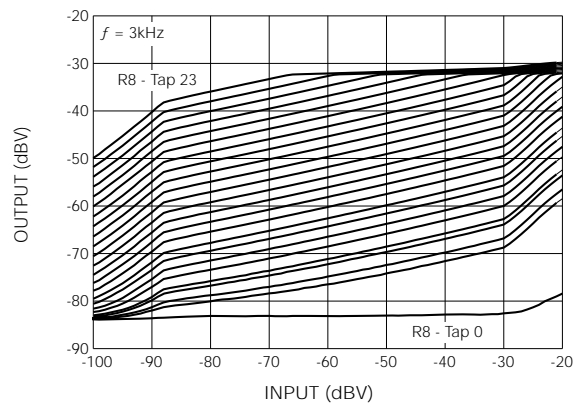

Fig. 10 System Volume Control
(Tap 0 - 0kΩ, Tap 23 - 92kΩ)

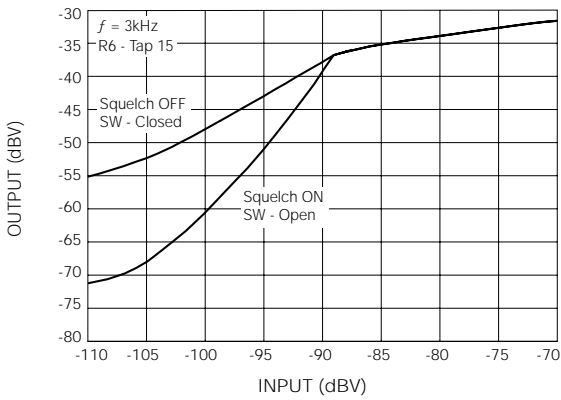

Fig. 11 Low Level Squelch Control

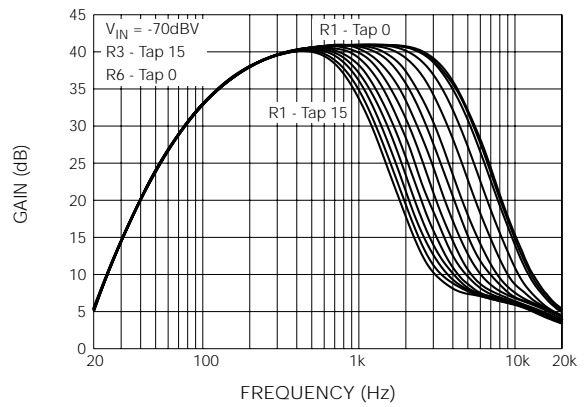

Fig. 12 SVF Crossover Frequency - Low Pass (Tap 0 - 0kΩ, Tap 15 - 64kΩ)

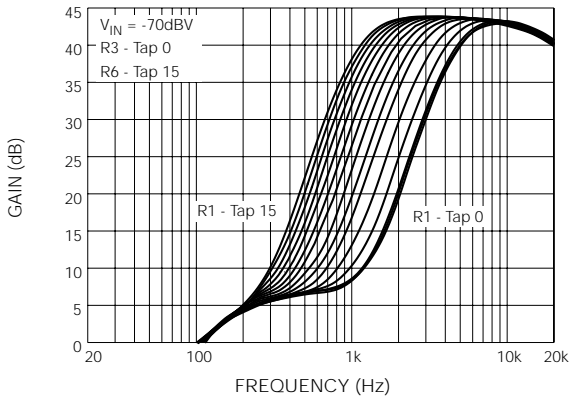

Fig. 13 SVF Crossover Frequency - High Pass (Tap 0 - 0kΩ, Tap 15 - 64kΩ)

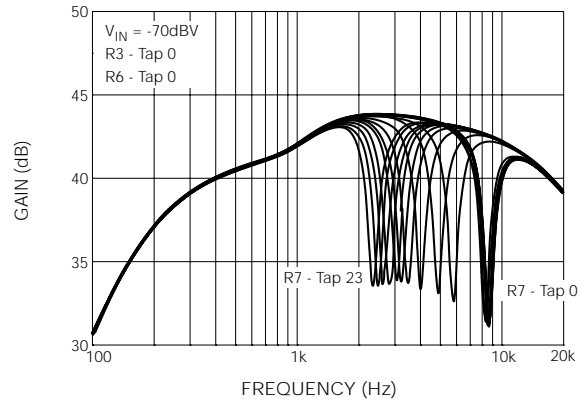

Fig. 14 Notch Frequency Control (Tap 0 - 0kΩ, Tap 15 - 460kΩ)

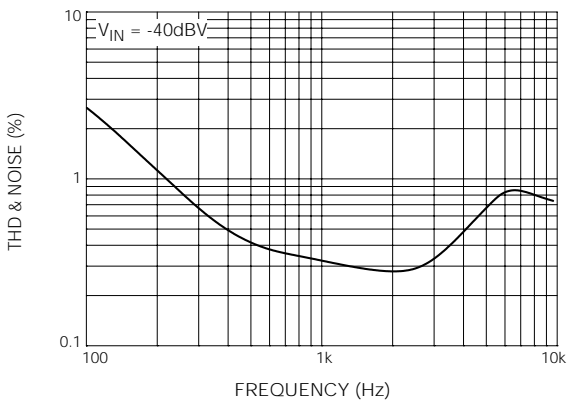

Fig. 15 THD and Noise vs. Frequency

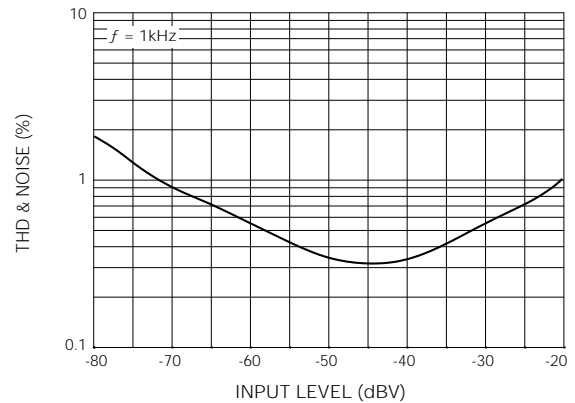

Fig. 16 THD and Noise vs. Input Level

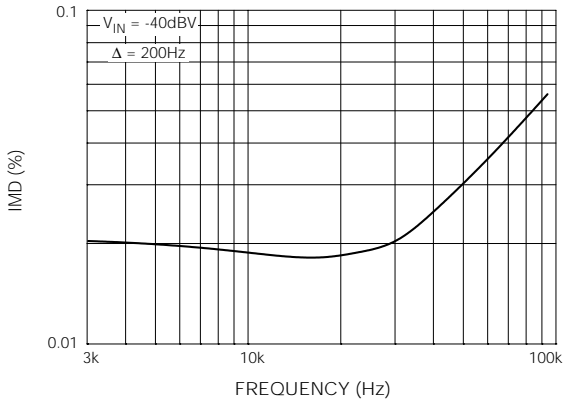

Fig. 17 Intermodulation Distortion (CCIF) vs. Frequency

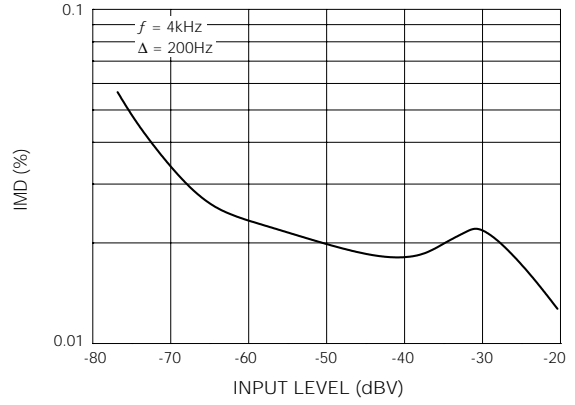

Fig. 18 Intermodulation Distortion (CCIF) vs. Input Level

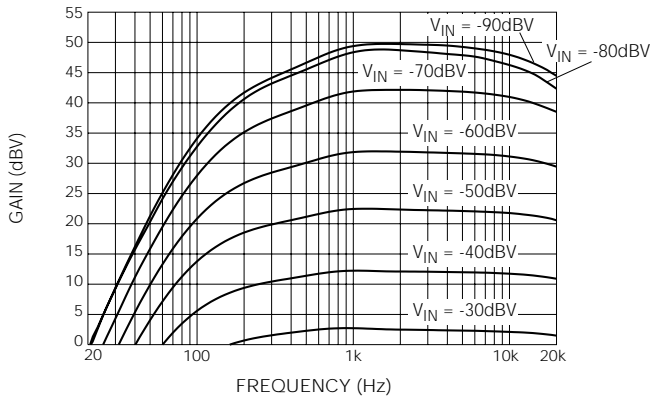

Fig. 19 Frequency Response for Different Input Levels

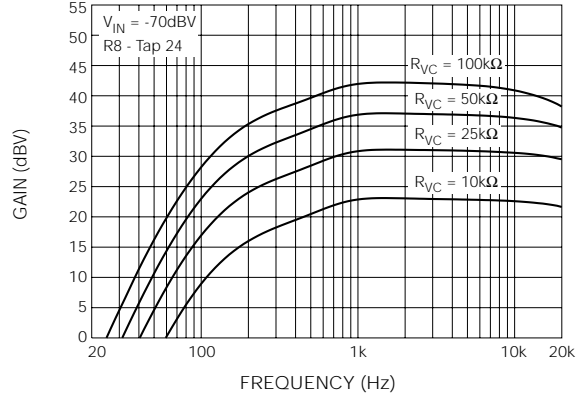
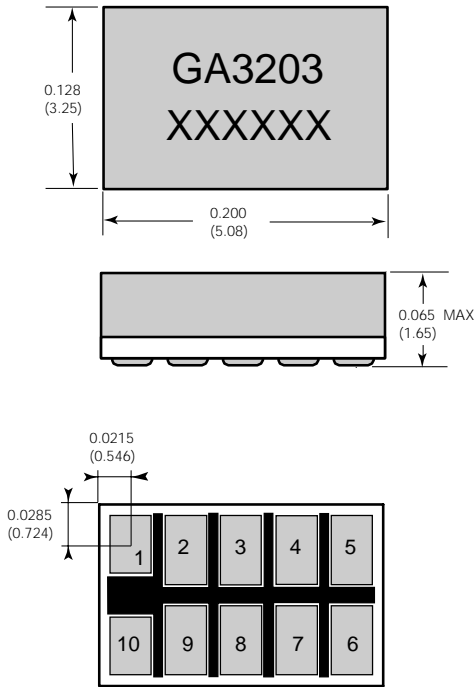

Fig. 20 Frequency Response for Different External Volume Control Resistor Values

PACKAGE DIMENSIONS



PAD LOCATIONS

PAD NO.	PAD POSITION		PAD DIMENSION		
	X	Y	Xdim	Ydim	
1	0	0	29.0	41.0	MIL
2	39.5	-4.0	30.0	49.0	
3	78.5	-4.0	28.0	49.0	
4	117.0	-4.0	29.0	49.0	
5	156.5	-4.0	30.0	49.0	
6	156.5	-67.5	30.0	48.0	
7	117.0	-67.5	29.0	48.0	
8	78.5	-67.5	28.0	48.0	
9	39.5	-67.5	30.0	48.0	
10	0	-71.5	29.0	40.0	
1	0	0	0.737	1.041	mm
2	1.003	-0.102	0.762	1.245	
3	1.994	-0.102	0.711	1.245	
4	2.972	-0.102	0.737	1.245	
5	3.975	-0.102	0.762	1.245	
6	3.975	-1.715	0.762	1.219	
7	2.972	-1.715	0.737	1.219	
8	1.994	-1.715	0.711	1.219	
9	1.003	-1.715	0.762	1.219	
10	0	-1.816	0.737	1.016	

GA3203

Dimensions are in inches.

Dimensions in parenthesis are in millimetres converted from inches and include minor rounding errors.

1.0000 inches = 25.400mm

Dimension tolerances: ± 0.003 (±0.08) unless otherwise stated.

Minimum pad sizes: 0.0290 x 0.0400 (0.737 x 1.016).

XXXXXX: work order number.

This hybrid is designed for either point-to-point soldering or reflow according to Gennum's recommended reflow process (Information Note 521-45).

GENNUM CORPORATION

MAILING ADDRESS:
 P.O. Box 489, Stn A, Burlington Ontario, Canada L7R 3Y3
 Tel. +1 (905) 632-2996 fax: +1 (905) 632-2814
 SHIPPING ADDRESS:
 970 Fraser Drive, Burlington, Ontario, Canada L7L 5P5

GENNUM JAPAN CORPORATION

C-101, Miyamae Village, 2-10-42 Miyamae, Suginami-ku, Tokyo 168-0081, Japan
 Tel. +81 (3) 3334-7700 Fax: +81 (3) 3247-8839

REVISION NOTES:
 Error Correction.
 For latest product information, visit www.gennum.com

DOCUMENT IDENTIFICATION
 PRELIMINARY DATA SHEET
 The product is in pre-production phase and specifications are subject to change without notice.