

FEATURES

- 6 programmable parameters
- 38dB maximum system gain
- 8:1 compression ratio
- output compression threshold, adjustable over 22dB range
- 2nd order active low cut filter adjustable from 530Hz to 2.0kHz
- low frequency boost
- 1st order high cut filter
- programmable or manual volume control
- multimemory
- averaging detector

thinSTAX™ PACKAGING

Hybrid typical dimensions:

0.195 x 0.110 x 0.070in.
(4.95 x 2.79 x 1.78 mm)

DESCRIPTION

The GA3206 programmable hybrid is composed of an AGC amplifier and the GP523 controller memory chip. The hybrid features AGC-O capability for low distortion output limiting and offers a package size suitable for CIC instruments.

The compression circuit operates with an 8:1 compression ratio and uses an averaging detector with a time constant of 270ms, selected to provide optimal sound quality over a full range of sound and listening environments. The actual attack and release times are typically 40ms and 150ms respectively when the circuit is fully in the compression region of operation (measured times will vary depending on gain and threshold settings).

The GA3206 features six programmable parameters: VC adjustment, threshold adjustment, high and low cut filters, gain trim and low frequency boost.

Four independent memories add to the flexibility of this hybrid.

The output stage is designed as a preamplifier for the class D integrated receiver.

The GA3206 hybrid code programmed into the GP523 is "3".

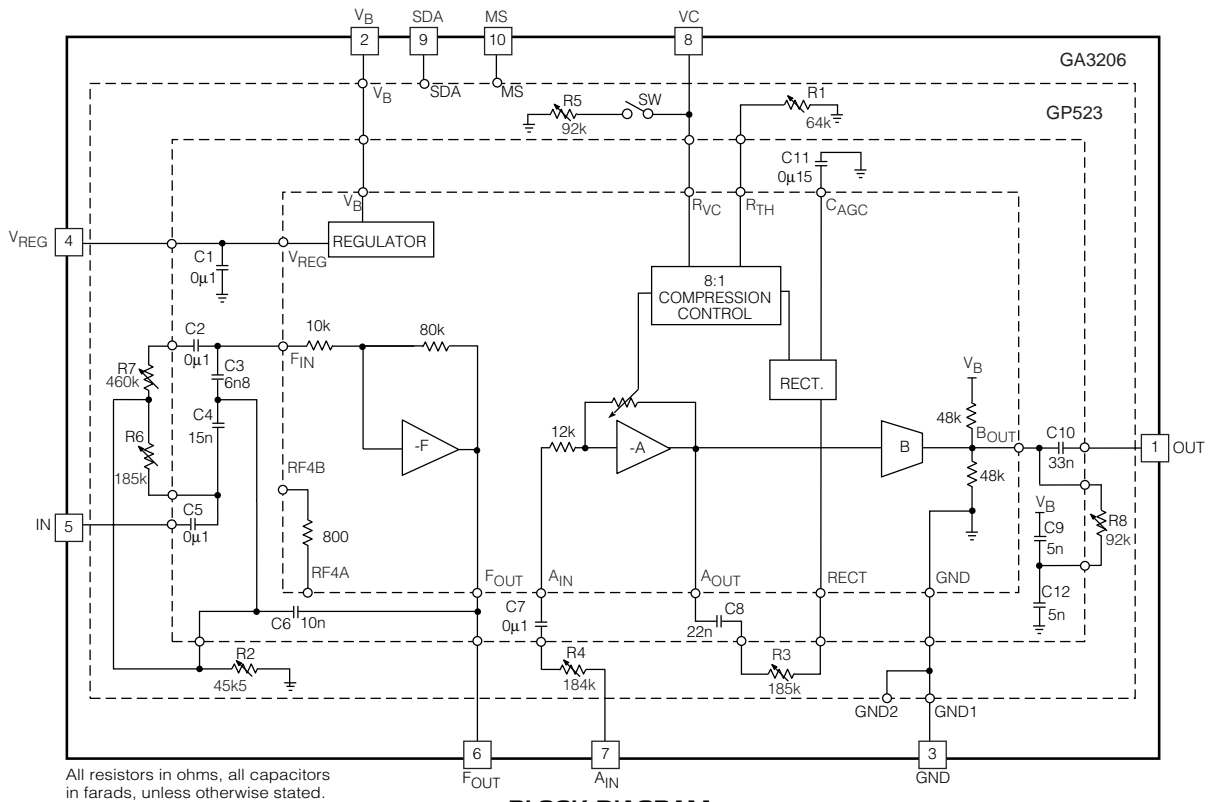

BLOCK DIAGRAM

ABSOLUTE MAXIMUM RATINGS

PARAMETER	VALUE
Supply Voltage	2VDC
Power Dissipation	25mW
Operating Temperature Range	-10°C to 40°C
Storage Temperature Range	-20°C to 70°C

CAUTION
ELECTROSTATIC
SENSITIVE DEVICES
DO NOT OPEN PACKAGES OR HANDLE
EXCEPT AT A STATIC-FREE WORKSTATION

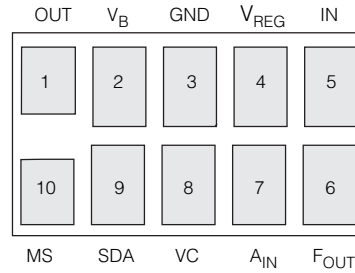
**PAD CONNECTION****ELECTRICAL CHARACTERISTICS**

Conditions: Frequency = 1 kHz, Temperature = 25°C, Supply Voltage $V_B = 1.3V$

The programmable parameters are adjusted to the following set values unless otherwise specified.

(THR) R1 - Tap 0, R3 - Tap 0; (VC) R5 - Tap 15; (Gain) R4 - Tap 0; (LPF) R8 - Tap 24; (HPF) R2 - Tap 15; (LF Boost) R6 - Tap 15, R7 - Tap 24; SW closed.

PARAMETER	SYMBOL	CONDITIONS	MIN	TYP	MAX	UNITS
Hybrid Current	I_{AMP}		-	275	380	μA
Minimum Supply Voltage	V_B		-	1.1	-	V
Total Harmonic Distortion	THD	$V_{IN} = -60dBV$	-	0.5	1	%
Input Referred Noise	IRN	A Weighted	-	4.4	-	μV_{RMS}
System Gain	A_S		34	37	40	dB
System Gain at Acoustic Peak	A_V	Frequency = 2.8kHz, R2 - Tap15	33	36	39	dB
Relative Gain at Acoustic Peak, Low Cut, Note 2	ΔA_V	Frequency = 2.8kHz, R2 - Tap1	-	-1	-	dB
Relative Gain at 500Hz, Note 2	ΔA_{LF}	Frequency = 500Hz, R2 - Tap15	-	-1	-	dB
Relative Gain at 500Hz, Low Cut, Note 2	ΔA_{LC}	Frequency = 500Hz, R2 - Tap1	-22	-19	-16	dB
Relative Gain at 5kHz, Note 2	ΔA_{HF}	Frequency = 5kHz, R2 - Tap15	-	-3	-	dB
Gain Trim Adjustment	ΔA_{VTRIM}	R4 - Tap 0 to R4 - Tap 15	21	24	27	dB
Regulator Voltage	V_{REG}		890	935	1000	mV
Power Supply Rejection Ratio	PSRR		49	56	-	dB
AGC						
Maximum Threshold (O/P Referred)	TH_{MAX}	R1 - Tap 0, R3 - Tap 15	-21	-19	-17	dBV
Minimum Threshold (O/P Referred)	TH_{MIN}	R1 - Tap 15, R3 - Tap 0	-50	-47	-44	dBV
VC Gain Range	ΔA_{VC}	R5 - Tap 0, R5 - Tap 15	17	20	23	dB
Compression Ratio High Threshold	CMP-H	$V_{IN} = -60dBV$ to $-30dBV$, R1 - Tap 0	7.5	8.5	9.5	ratio
Compression Ratio Low Threshold	CMP-L	$V_{IN} = -70dBV$ to $-40dBV$, R1 - Tap 15	6.3	7.3	8.3	ratio
Stage A Gain	A_A	$V_{IN} = -70dBV$	24	27	30	dB
Compression Gain Range	A_{RANGE}	Note 1	45	49	53	dB
AGC Time Constant	τ_{AGC}		-	270	-	ms

All parameters and switches remain as shown in the Test Circuit unless otherwise stated in CONDITIONS column.

Note: 1. $A_{RANGE} = A_A - A_A [V_{IN} = -20dBV, R1 - Tap 15]$

2. Relative to System Gain at Acoustic Peak.

ELECTRICAL CHARACTERISTICS continued

Conditions: Frequency = 1 kHz, Temperature = 25°C, Supply Voltage $V_B = 1.3V$

The programmable parameters are adjusted to the following set values unless otherwise specified.

(THR) R1 - Tap 0, R3 - Tap 0; (VC) R5 -Tap 15; (Gain) R4 - Tap 0; (LPF) R8 - Tap 24; (HPF) R2 - Tap 15; (LF Boost) R6 - Tap 15, R7 - Tap 24; SW closed.

PARAMETER	SYMBOL	CONDITIONS	MIN	TYP	MAX	UNITS
OUTPUT STAGE						
Gain	A_B		-	11	-	dB
Output Resistance	R_{OP}		-	24	-	k Ω
HIGH PASS FILTER						
Minimum Corner Frequency	f_{C-MIN}	R2 - Tap15	-	530	-	Hz
Maximum Corner Frequency	f_{C-MAX}	R2 - Tap1	-	2.0	-	kHz
Low Frequency Boost	A_{BOOST}	at 300Hz, R6 - Tap 0, R7 - Tap 0	14	17	20	dB
LOW PASS FILTER						
Filter Adjustment Range	A_{LPF}	at 5kHz, R8 - Tap 0 to R8 - Tap 24	12	15	18	dB

All parameters and switches remain as shown in the Test Circuit unless otherwise stated in CONDITIONS column.

SUPPORT SOFTWARE

All support software for the GA3206 and the GP523 is available from Gennum's web site:

www.gennum.com/hip/software

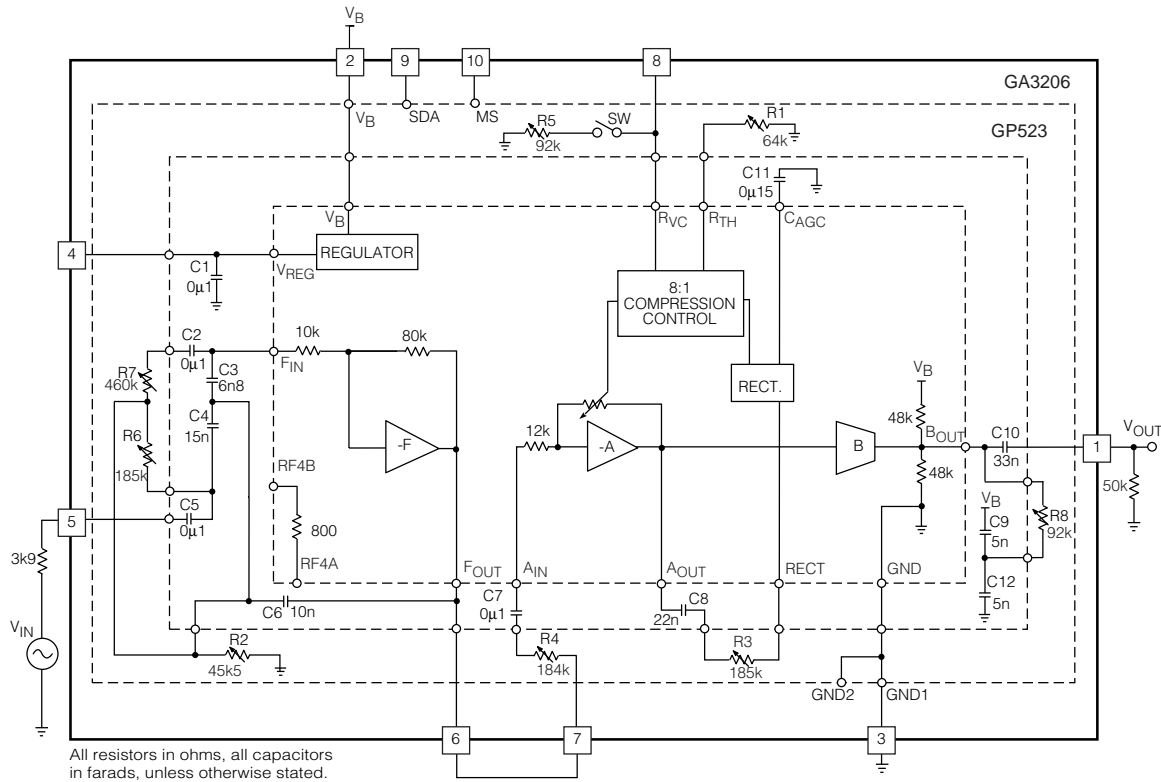

Fig. 1 Production Test Circuit

TABLE OF DEFAULTS

R1 - Tap 0	R5 - Tap15
R2 - Tap 15	R6 - Tap 15
R3 - Tap 0	R7 - Tap 24
R4 - Tap 0	R8 - Tap 24
SW Closed	

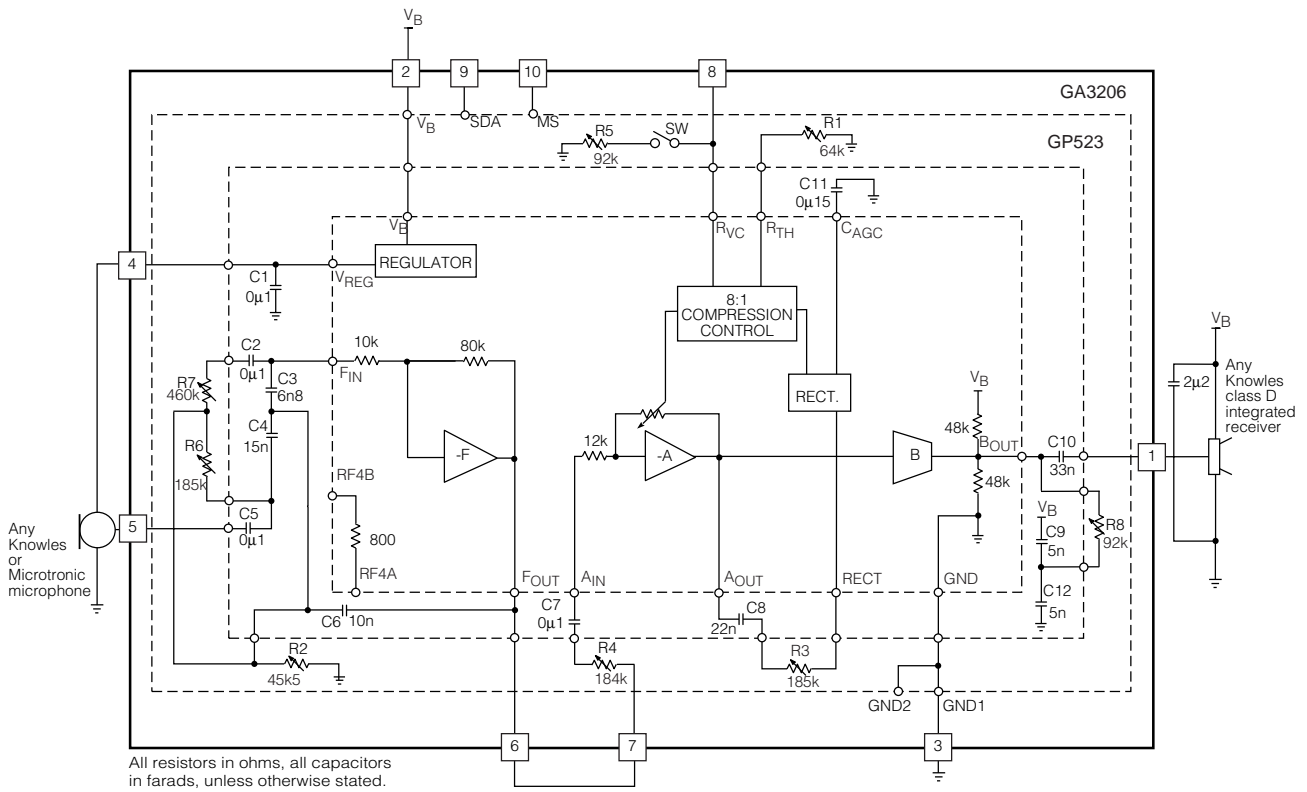

Fig. 2 Typical Application Circuit

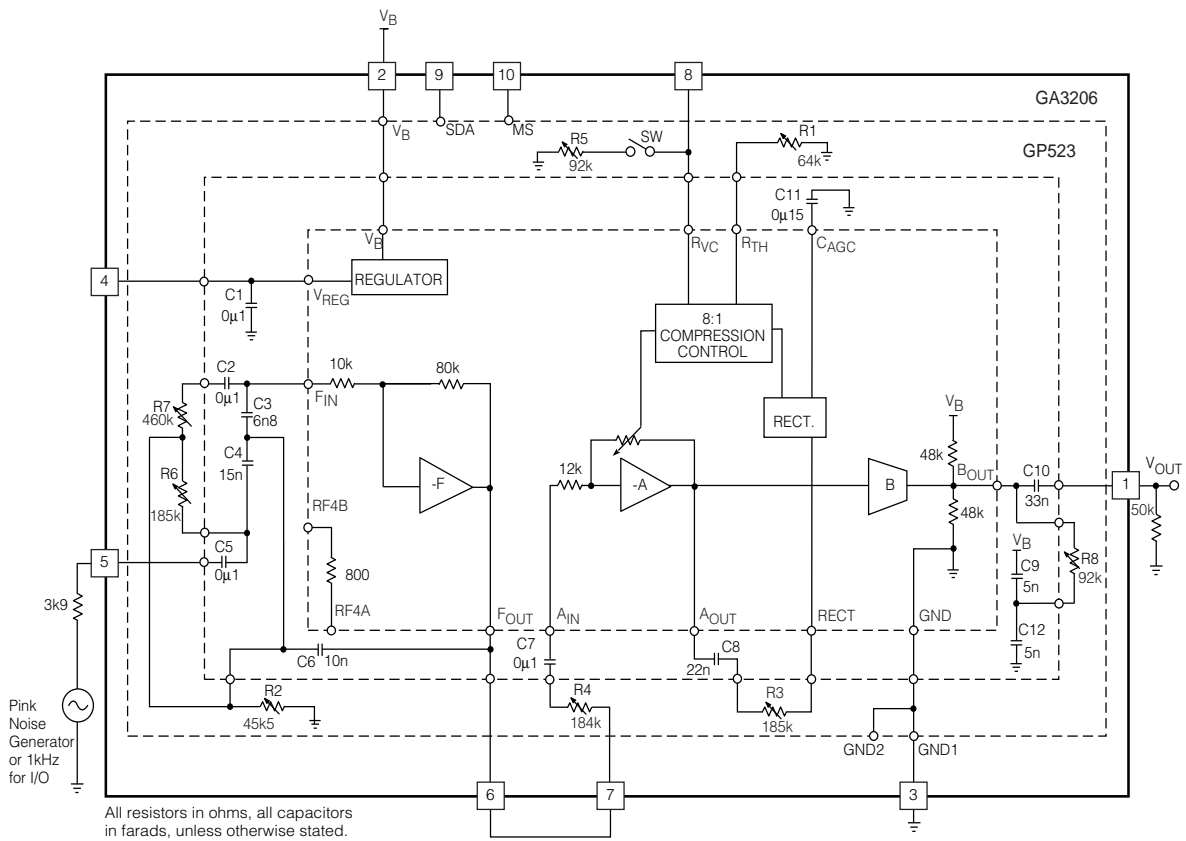

Fig. 3 Characterization Circuit (used to generate typical curves)

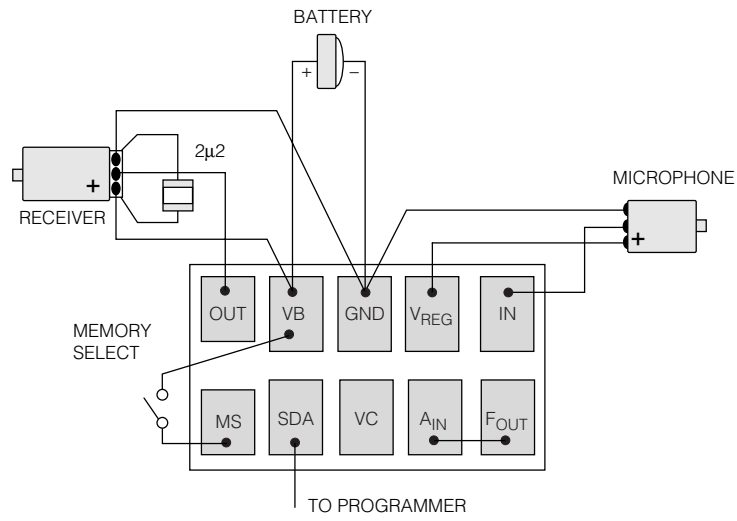

Fig. 4 Typical Hearing Instrument Assembly Diagram

TYPICAL PERFORMANCE CURVES

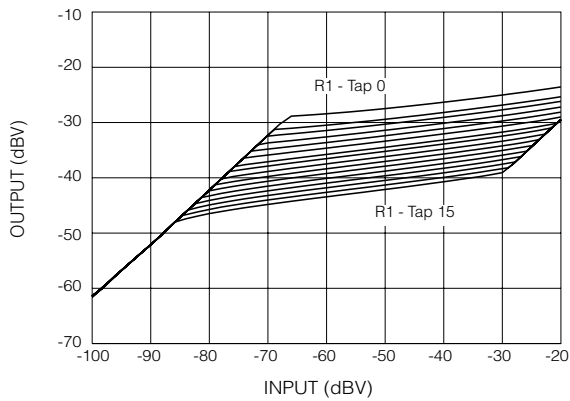

Fig. 5 Input vs Output Threshold Settings using R1 (Tap 0 – 0kΩ, Tap 15 – 64kΩ)

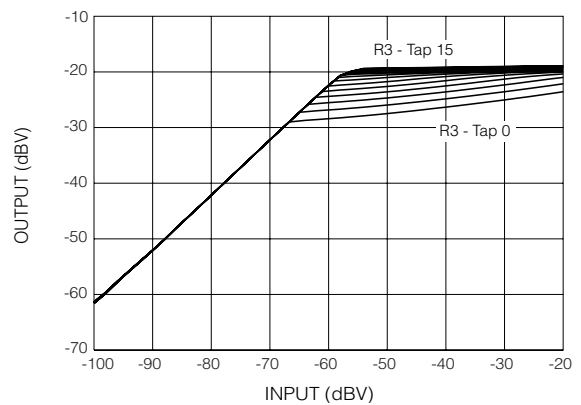

Fig. 6 Input vs Output Threshold Settings using R3 (Tap 0 – 0kΩ, Tap 15 – 185kΩ)

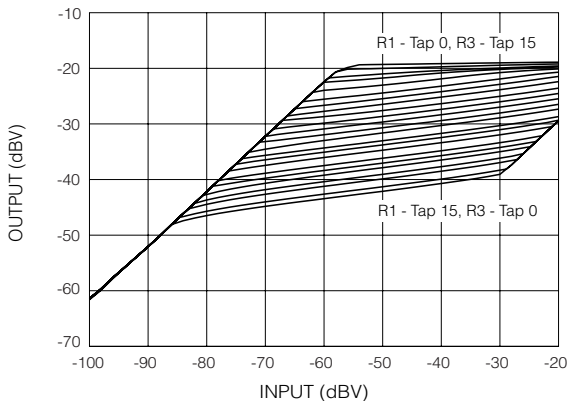

Fig. 7 Input vs Output Threshold Settings in 1dB Steps using R1 and R3
(See GA3206 Application Note, Document 522-56)

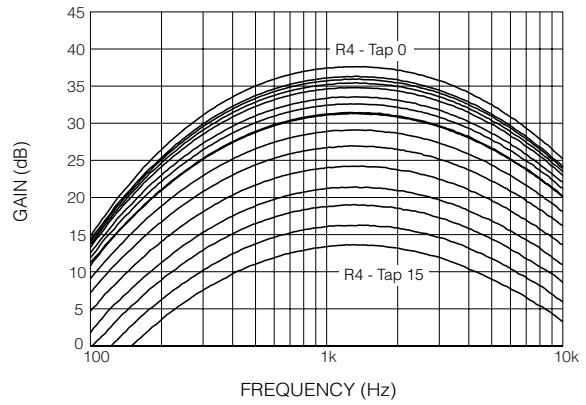

Fig. 8 Frequency Response vs R4 Gain Trim Settings
(Tap 0 – 0kΩ, Tap 15 – 184kΩ)

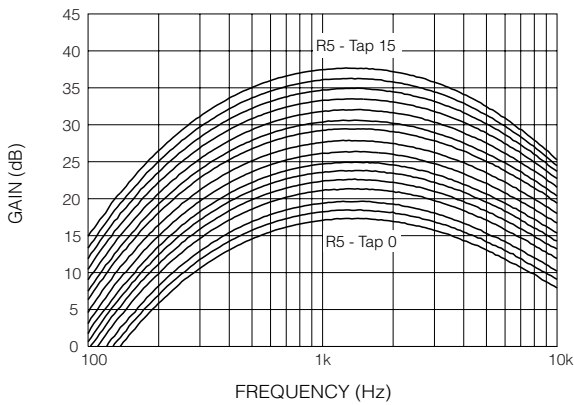

Fig. 9 Frequency Response vs R5 Volume Control Settings
(Tap 0 – 7.3kΩ, Tap 15 – 92kΩ)

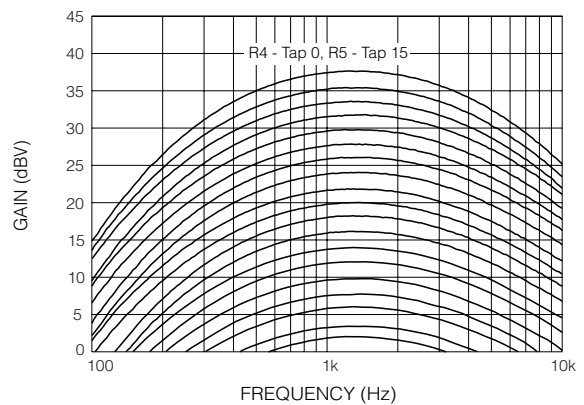

Fig. 10 Gain Adjustment in 2dB Steps using R4 and R5
(See GA3206 Application Note, Document 522-56)

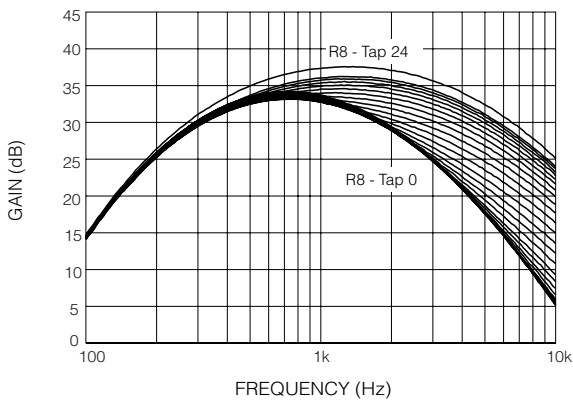

Fig. 11 Frequency Response vs R8 High Cut Settings
(Tap 0 – 0kΩ, Tap 24 – OPEN)

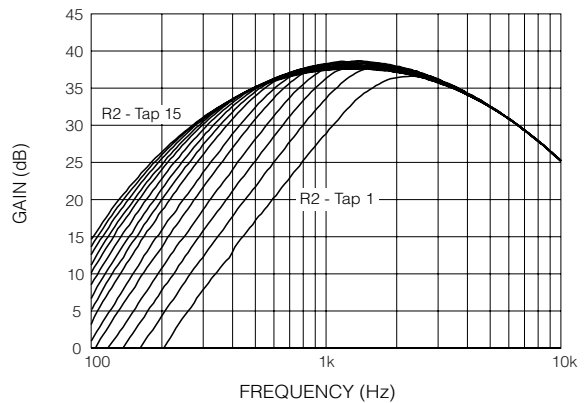

Fig. 12 Frequency Response vs R2 Low Cut Settings
(Tap 0 – 0kΩ, Tap 15 – 45.5kΩ)

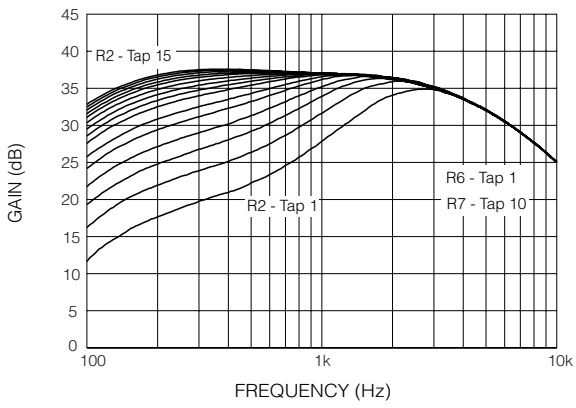

Fig. 13 Frequency Response vs R2 Low Cut Settings with Low Frequency Boost
(See GA3206 Application Note, Document 522-56)

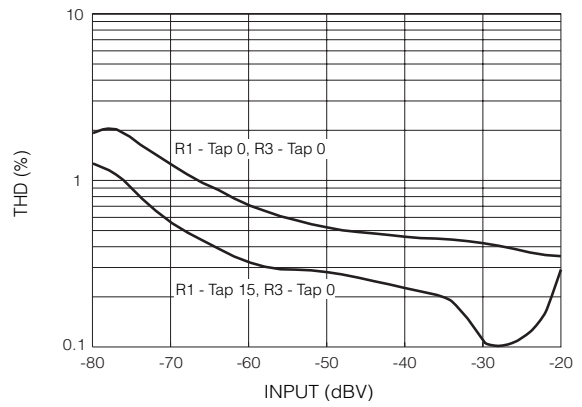

Fig. 14 THD vs Input

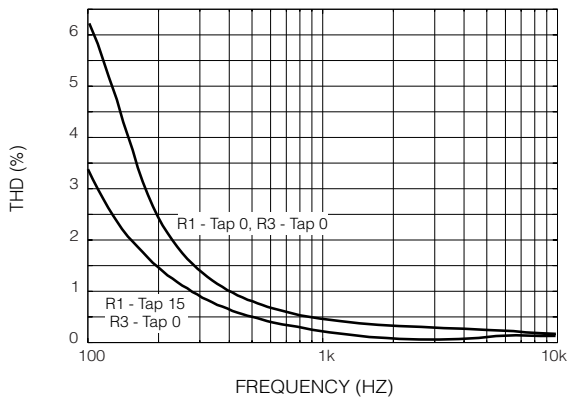

Fig. 15 THD vs Frequency

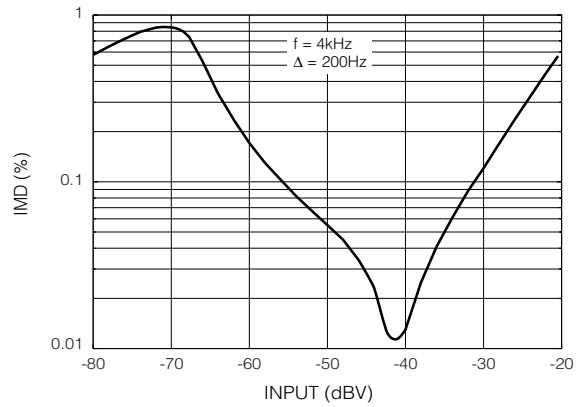

Fig. 16 Intermodulation Distortion vs Input

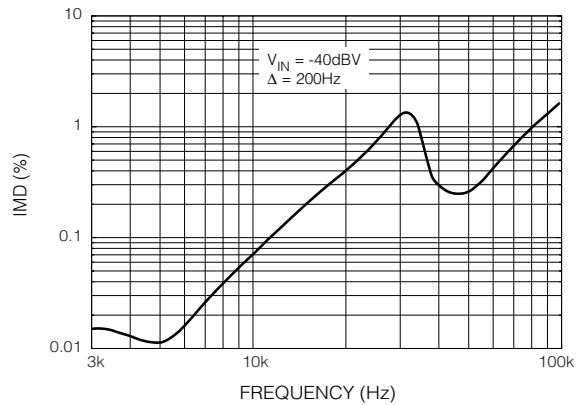
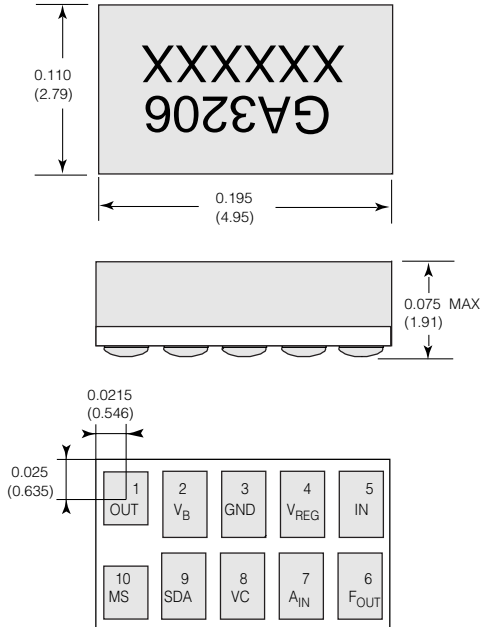

Fig. 17 Intermodulation Distortion vs Frequency

GA3206

PACKAGE DIMENSIONS



PAD LOCATIONS

PAD NO.	PAD POSITION		PAD DIMENSION		
	X	Y	Xdim	Ydim	
1	0	0	28.0	35.0	MIL
2	38.0	-2.5	28.0	40.0	
3	76.0	-2.5	28.0	40.0	
4	114.0	-2.5	28.0	40.0	
5	152.0	-2.5	28.0	40.0	
6	152.0	-57.5	28.0	40.0	
7	114.0	-57.5	28.0	40.0	
8	76.0	-57.5	28.0	40.0	
9	38.0	-57.5	28.0	40.0	
10	0	-60.0	28.0	35.0	
1	0	0	0.711	0.889	mm
2	0.965	-0.064	0.711	1.016	
3	1.930	-0.064	0.711	1.016	
4	2.896	-0.064	0.711	1.016	
5	3.861	-0.064	0.711	1.016	
6	3.861	-1.461	0.711	1.016	
7	2.896	-1.461	0.711	1.016	
8	1.930	-1.461	0.711	1.016	
9	0.965	-1.461	0.711	1.016	
10	0	-1.524	0.711	0.889	

Note: Centre of pad 1 has coordinates 0, 0.

Dimensions are in inches.
 Dimensions shown in parenthesis are in millimetres converted from inches and include minor rounding errors.
 1.000 inches = 25.4mm.
 Dimension tolerances: ±0.003 (+0.08) unless otherwise stated.
 Smallest pad size: 0.035 x 0.028in (0.89 x 0.71mm).
 XXXXXX: work order number.
 This hybrid is designed for either point-to-point manual soldering or for reflow according to Gennum's recommended reflow process (Information Note 521-45).

GENNUM CORPORATION
 MAILING ADDRESS:
 P.O. Box 489, Stn. A, Burlington, Ontario, Canada L7R 3Y3
 Tel. +1 (905) 632-2996 Fax +1 (905) 632-2814
 SHIPPING ADDRESS:
 970 Fraser Drive, Burlington, Ontario, Canada L7L 5P5

GENNUM JAPAN CORPORATION
 C-101, Miyamae Village, 2-10-42 Miyamae, Suginami-ku, Tokyo 168-0081,
 Japan Tel. +81 (3) 3334-7700 Fax: +81 (3) 3247-8839

DOCUMENT IDENTIFICATION:
 PRELIMINARY DATA SHEET
 The product is in pre-production phase and specifications are subject to change without notice.

REVISION NOTES:
 Existing diagrams adjusted; characterization diagram added; graphs and table added; dimension diagram replaced.