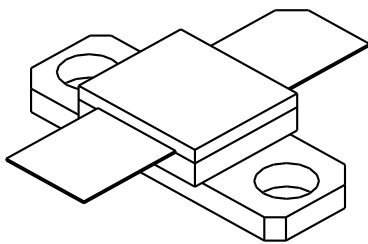

2015 M

15 Watts - 28 Volts, Class C
Microwave 2000 MHz

<p>GENERAL DESCRIPTION The 2015M is a COMMON BASE transistor capable of providing 15 Watts Class C, RF output power at 2000 MHz. It includes input prematching and utilizes Gold metalization and diffused ballasting are used to provide high reliability and supreme ruggedness. The transistor uses a fully hermetic High Temperature Solder Sealed package.</p>	<p>CASE OUTLINE 55NV, Style 1</p> 
<p>ABSOLUTE MAXIMUM RATINGS</p> <p>Maximum Power Dissipation @ 25°C 50 Watts</p> <p>Maximum Voltage and Current</p> <p>BVces Collector to Emitter Voltage 50 Volts BVebo Emitter to Base Voltage 3.5 Volts Ic Collector Current 3.0 A</p> <p>Maximum Temperatures</p> <p>Storage Temperature - 65 to + 200°C Operating Junction Temperature + 200°C</p>	

ELECTRICAL CHARACTERISTICS @ 25 °C

SYMBOL	CHARACTERISTICS	TEST CONDITIONS	MIN	TYP	MAX	UNITS
P _{out}	Power Out	F = 2 GHz	15.0			Watt
P _{in}	Power Input	V _{cb} = 28 Volts			3.75	Watt
P _g	Power Gain	P _o = 15 Watts	6.0	7.0		dB
η _c	Collector Efficiency	As Above		40		%
VSWR ₁	Load Mismatch Tolerance	F = 2 GHz, P _o = 15 W			10:1	

BVces	Collector to Emitter Breakdown	I _c = 60 mA	50			Volts
BVcbo	Collector to Base Breakdown	I _c = 6 mA	45			Volts
BVebo	Emitter to Base Breakdown	I _e = 6 mA	3.5			Volts
Icbo	Collector to Base Current	V _{cb} = 28 Volts			3	mA
h _{FE}	Current Gain	V _{ce} = 5 V, I _c = 600 mA	15		120	
Cob	Output Capacitance	F = 1 MHz, V _{cb} = 28 V		22		pF
θ _{jc}	Thermal Resistance				3.5	°C/W

Issue August 1996

GHz TECHNOLOGY INC. RESERVES THE RIGHT TO MAKE CHANGES WITHOUT FURTHER NOTICE. GHz RECOMMENDS THAT BEFORE THE PRODUCT(S) DESCRIBED HEREIN ARE WRITTEN INTO SPECIFICATIONS, OR USED IN CRITICAL APPLICATIONS, THAT THE PERFORMANCE CHARACTERISTICS BE VERIFIED BY CONTACTING THE FACTORY.

POWER OUTPUT VS FREQUENCY

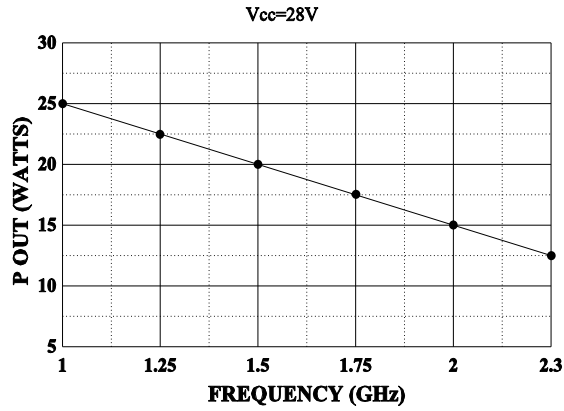

EFFICIENCY VS FREQUENCY

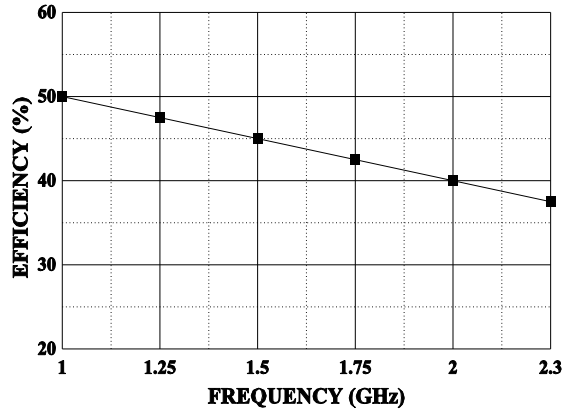

POWER OUTPUT VS POWER INPUT

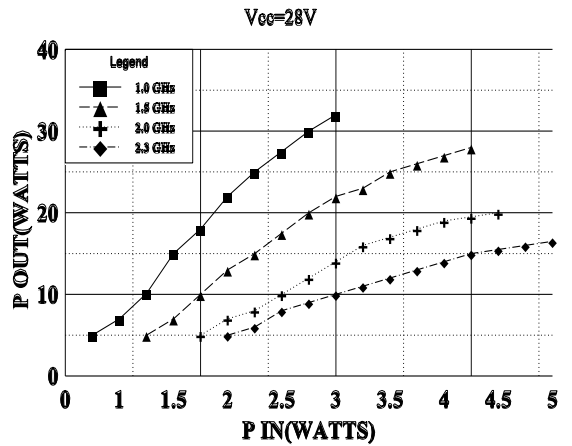

SMITH CHART

NORMALIZED IMPEDANCE AND ADMITTANCE COORDINATES
Vcc= 28V

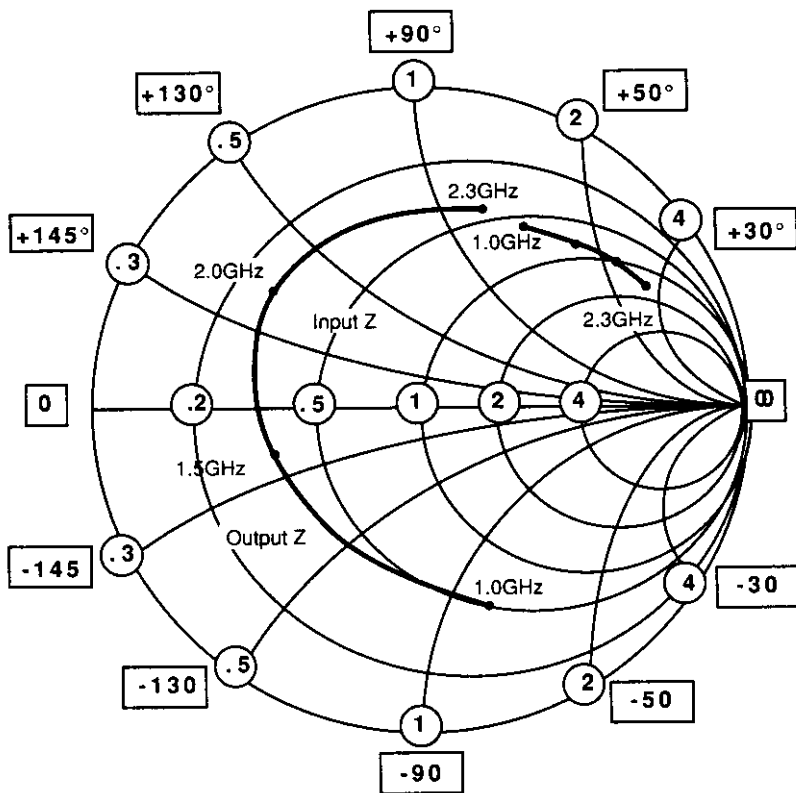

NORMALIZED TO A 5 OHM SYSTEM.

REVISIONS

ZONE	REV	DESCRIPTION	DATE	APPROVED
------	-----	-------------	------	----------

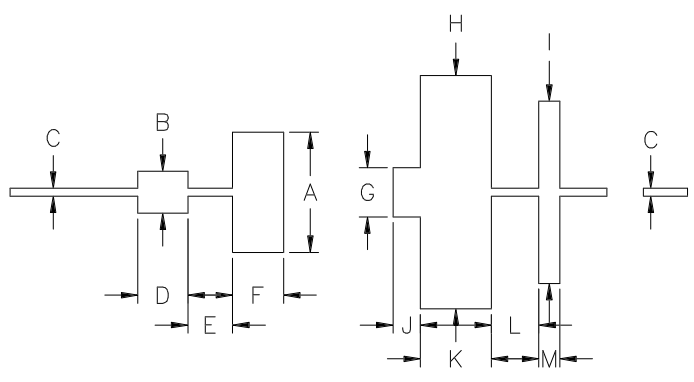

DIM	INCHES
A	.660
B	.230
C	.043
D	.275
E	.245
F	.280
G	.370
H	1.280
I	1.000
J	.150
K	.390
L	.260
M	.115

2015M TEST AMPLIFIER
(NA) MHz BANDWIDTH

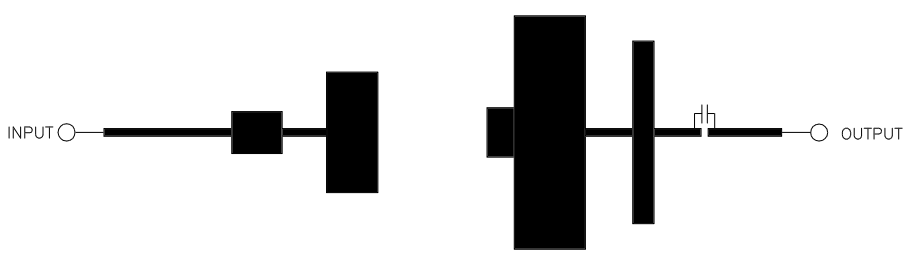

— = Microstrip on 0.015" Duroid, Er=2.3



CAGE OPJR2	DWG NO. 2015M	REV A
	SCALE 1/1	SHEET