

Micro-power Step-Up DC/DC Converters in SOT23-5

Features

- Configurable Output Voltage Up to 28V
- 20 μ A Quiescent Current
- <1 μ A Shutdown Current
- <1 μ A Shutdown Pin Current
- Supply Range from 2.5V to 6.5V
- Low $V_{DS(on)}$: 250mV ($I_{SW}=300mA$)
- Tiny SOT23-5 Package

Applications

- STN/TFT LCD Bias
- Personal Digital Assistants (PDAs)
- Handheld Computers
- Digital Still Cameras
- Cellular Phones
- WebPad
- White LED Driver
- Local 3V to 5V Conversion

General Description

The G5111 boost converter is designed for small/ medium size LCD panel of high bias voltage.

Due to a typical 20 μ A quiescent current and 2.5V~6.5V supply voltage range, it is suitable for battery powered portable applications. Such as PDAs and Handheld Computers. When the IC sets to shutdown mode, it only consumes less than 1 μ A.

Furthermore, the 350mA current limit, 500ns fixed minimum off-time and tiny SOT23-5 package facilitates the use of smaller inductor and other surface-mount components to minimize the PCB size in those space-conscious applications.

To control the IC, no other external current is needed for the shutdown pin. It typically consumes less than 1 μ A of full supply range.

Ordering Information

PART	TEMP. RANGE	PIN-PACKAGE	TOP MARK
G5111 T11	-40°C ~ +85°C	SOT23-5	51xx
G5111 T12	-40°C ~ +85°C	SOT23-5	52xx

Pin Configuration

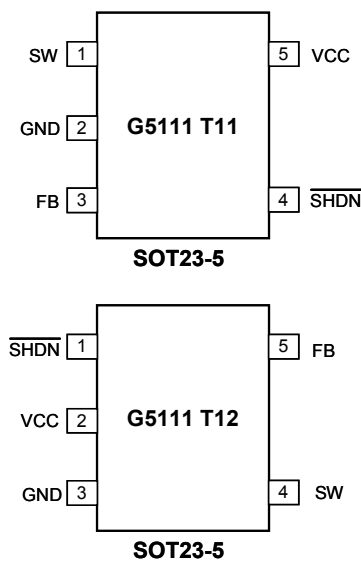

Typical Application Circuit

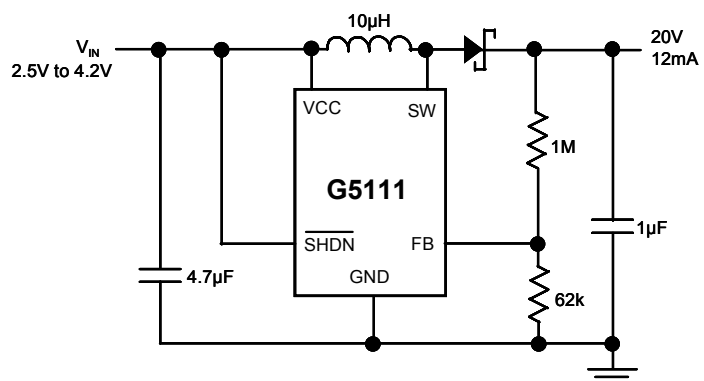

Absolute Maximum Ratings

SW to GND.....	-0.3V to +30V	Junction Temperature	+125°C
FB to GND.....	-0.3V to V_{CC}	Storage Temperature.....	-65°C to +150°C
V_{CC} , SHDN to GND.....	-0.3V to +7V	Lead Temperature (Soldering, 10 sec).....	+300°C
Operating Temperature Range (Note 1) ..	-40°C to +85°C		

Stress beyond those listed under "Absolute Maximum Rating" may cause permanent damage to the device.

Electrical Characteristics

($V_{CC} = 3.6V$, $V_{SHDN} = 3.6V$, $T_A = 25^\circ C$)

PARAMETER	CONDITIONS	MIN	TYP	MAX	UNITS
Input Voltage Range		2.5		6.5	V
Quiescent Current	Not Switching		20	30	μA
	$V_{SHDN} = 0V$		0.1	1	μA
FB Comparator Trip Point		1.18	1.2	1.22	V
Output Voltage Line Regulation	$2.5V < V_{IN} < 6.5V$		-0.05		%/V
FB Pin Bias Current (Note 2)	$V_{FB} = 1.2V$		30	80	nA
Switch Off Time	$V_{FB} > 1V$		500		ns
	$V_{FB} < 0.6V$		1.6		μs
Switch $V_{DS(ON)}$	$I_{SW} = 300mA$		250	350	mV
Switch Current Limit		300	350	400	mA
SHDN Pin Current			0.1	1	μA
SHDN Input Voltage High		0.9			V
SHDN Input Voltage Low				0.25	V
Switch Leakage Current	Switch Off, $V_{SW} = 28V$		0.01	5	μA

Note 1: The G5111 are guaranteed to meet performance specifications from 0°C to 85°C. Specifications over the -40°C to 85°C operating temperature range are assured by design, characterization and correlation with statistical process controls.

Note 2: Bias current flows into the FB pin.

Block Diagram

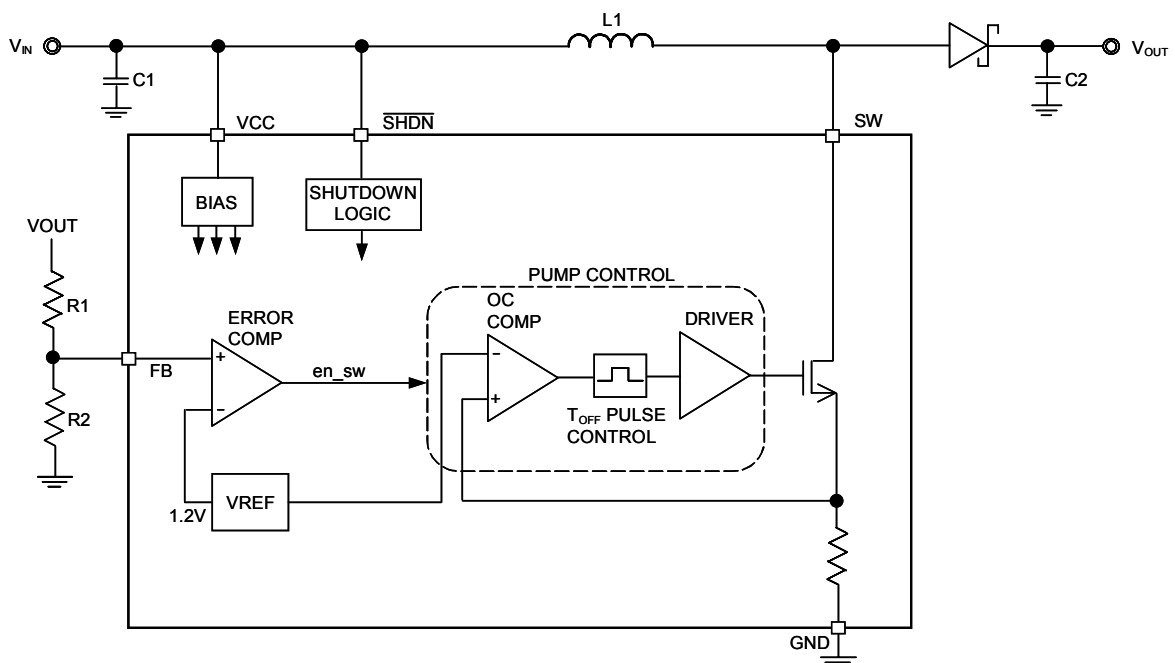

Typical Performance Characteristics

($V_{CC}=+3.6V$, $V_{SHDN}=+3.6V$, $L=10\mu H$, $T_A=25^\circ C$, unless otherwise noted.)

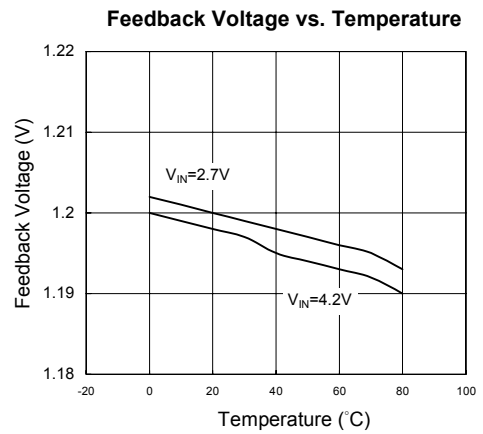
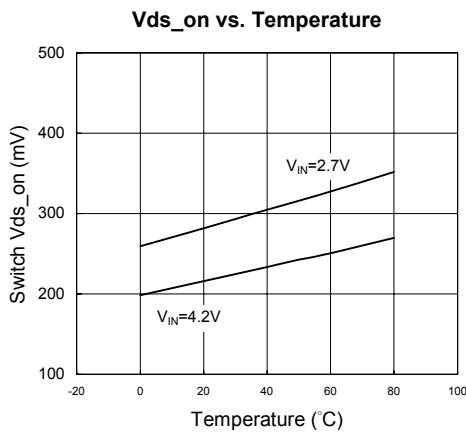
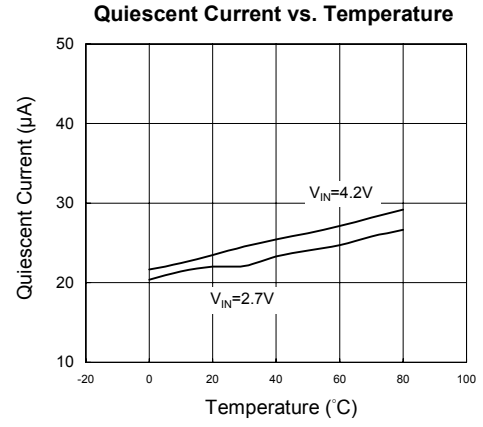
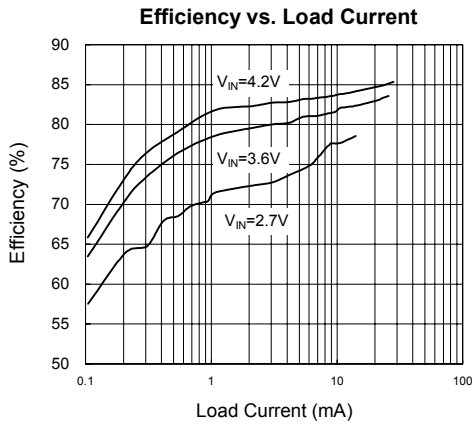
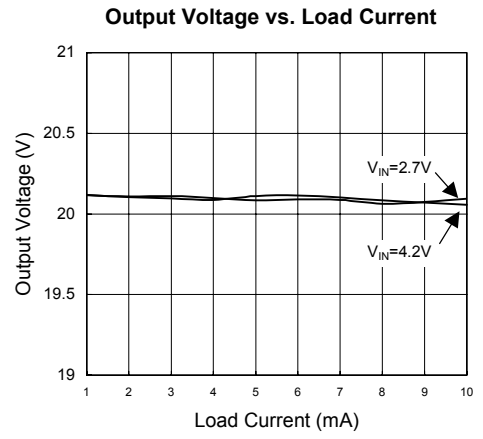
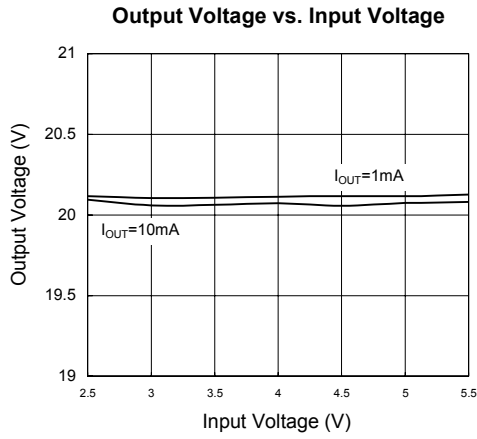

Typical Performance Characteristics (Continued)

FB Bias Current vs. Temperature

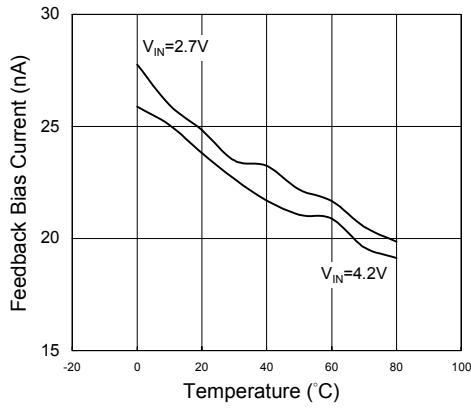

Switch Current Limit vs. Temperature

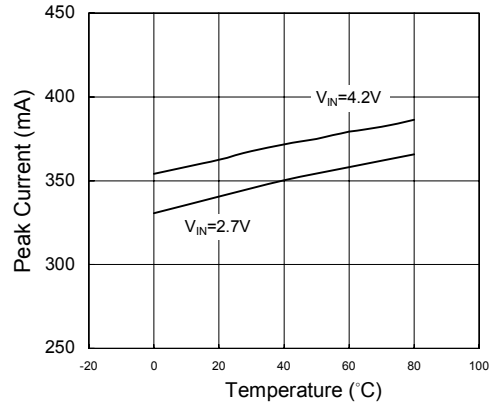

Line Transient

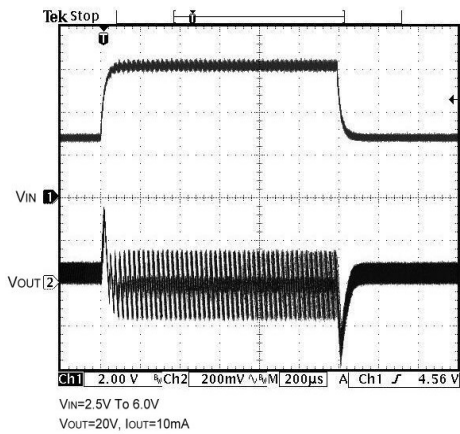

Load Transient

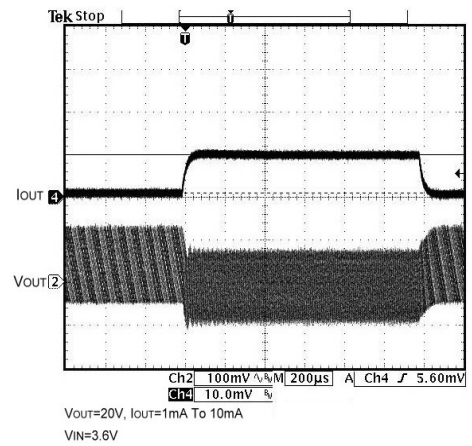

Pin Description

PIN		NAME	FUNCTION
T11	T12		
1	4	SW	Switch Pin. The drain of the internal NMOS power switch. Connect this pin to inductor.
2	3	GND	Ground.
3	5	FB	Feedback Pin. Set the output voltage by selecting values for R1 and R2 (see Block Diagram): $R1 = R2 \left(\frac{V_{OUT}}{1.2} - 1 \right)$
4	1	SHDN	Active-Low Shutdown Pin. Tie this pin to logic-high to enable the device or tied it to logic-low to turn this device off.
5	2	VCC	Input Supply Pin. Bypass this pin with a capacitor as close to the device as possible.

Function Description

The G5111 is a boost converter with a NMOS switch embedded (refer to Block Diagram). The boost cycle is getting started when FB pin voltage drop below 1.2V as the NMOS switch turns on. During the switch on period, the inductor current ramps up until 350mA current limit is reached. Then turns the switch off, while the inductor current flows through external schottky diode, and ramps down to zero. During the switch off period, the inductor current charges output capacitor and the output voltage is boosted up. This pumping mechanism continues cycle by cycle until the FB pin voltage exceed 1.2V and entering the none switching mode. In this mode, the G5111 consumes as low as 20uA typically to save battery power.

Applications Information

Choosing an Inductor

There are several recommended inductors that work well with the G5111 in Table 1. Use the equations and recommendations in the next few sections to find the proper inductance value for your design.

Table 1. Recommended Inductors

PART	VALUE(μH)	MAX DCR (Ω)	VENDOR
LQH3C4R7	4.7	0.26	Murata www.murata.com
LQH3C100	10	0.30	
LQH3C220	22	0.92	
CD43-4R7	4.7	0.11	Sumida www.sumida.com
CD43-100	10	0.18	
CDRH4D18-4R7	4.7	0.16	
CDRH4D18-100	10	0.20	
DO1608-472	4.7	0.09	Coilcraft www.coilcraft.com
DO1608-103	10	0.16	
DO1608-223	22	0.37	

Inductor Selection—Boost Regulator

The appropriate inductance value for the boost regulator application may be calculated from the following equation. Select a standard inductor close to this value.

$$L = \frac{V_{OUT} - V_{IN(MIN)} + V_D}{I_{LIM}} \times t_{OFF}$$

Where $V_D = 0.4V$ (Schottky diode voltage), $I_{LIM} = 350mA$ and $t_{OFF} = 500ns$. A larger value can be used to lightly increase the available output current, but limit it to about twice the calculating value. When too large of an inductor will increase the output voltage ripple without providing much additional output current. In varying V_{IN} condition such as battery power applications, use the minimum V_{IN} value in the above equation. A smaller value can be used to give smaller physical size, but the inductor current overshoot will be occurs (see Current Limit Overshoot section).

Inductor Selection—SEPIC Regulator

For a SEPIC regulator using the G5111, the approximate inductance value can be calculated by below formula. As for the boost inductor selection, a larger or smaller value can be used.

$$L = 2 \left(\frac{V_{OUT} + V_D}{I_{LIM}} \right) \times t_{OFF}$$

Current Limit Overshoot

The G5111 use a constant off-time control scheme, the power switch is turned off after the 350mA current limit is reached. When the current limit is reached and when the switch actually turns off, there is a 100ns delay time. During this time, the inductor current exceeds the current limit by a small amount. The formula below can calculate the peak inductor current.

$$I_{PEAK} = I_{LIM} + \left(\frac{V_{IN(MAX)} - V_{SAT}}{L} \right) \times 100ns$$

Where $V_{SAT} = 0.25V$ (switch saturation voltage). When the systems with high input voltages and uses smaller inductance value, the current overshoot will be most apparent. This overshoot can be useful as it helps increase the amount of available output current. To use small inductance value for systems design, the current limit overshoot can be quite high. Even if it is internally current limited to 350mA, the power switch of the G5111 can operate larger currents without any problem, but the total efficiency will suffer. The I_{PEAK} is keep below 500mA for the G5111 will be obtained best performance.

Capacitor Selection

Low ESR (Equivalent Series Resistance) capacitors should be used at the output to minimize the output ripple voltage and the peak-to-peak transient voltage. Multilayer ceramic capacitors (MLCC) are the best choice, as they have a very low ESR and are available in very small packages. Their small size makes them a good match with the G5111's SOT-23 package. If solid tantalum capacitors (like the AVX TPS, Sprague 593D families) or OS-CON capacitors are used, they will occupy more volume than a ceramic ones and the higher ESR increases the output ripple voltage. Notice that use a capacitor with a sufficient voltage rating.

A low ESR surface-mount ceramic capacitors also make a good selection for the input bypass capacitor, which should be placed as close as possible to the G5111. A 4.7 μ F input capacitor is sufficient for most applications.

Diode Selection

For most G5111 applications, the high switching frequency requires a high-speed rectifier Schottky diodes, such as the Motorola MBR0530 (0.5A, 30V) with their low forward voltage drop and fast switching speed, are

recommended. Many different manufacturers make equivalent parts, but make sure that the component is rated to operate at least 0.35A. To achieve high efficiency, the average current rating of the Schottky diodes should be greater than the peak switching current. Choose a reverse breakdown voltage greater than the output voltage.

Lowering Output Voltage Ripple

The G5111 supplies energy to the load in bursts by ramping up the inductor current, then delivering that current to the load. To use low ESR capacitors will help minimize the output ripple voltage, but proper selection of the inductor and the output capacitor also plays a big role. If a larger inductance value or a smaller capacitance value is used, the output ripple voltage will increase because the capacitor will be slightly overcharged each burst cycle. To reduce the output ripple, increase the output capacitance value or add a 10pF feed-forward capacitor in the feedback network of the G5111 (see the circuits in the Typical Applications section). To add this small, inexpensive 10pF capacitor will greatly reduce the output voltage ripple.

Typical Applications

Boost Converter

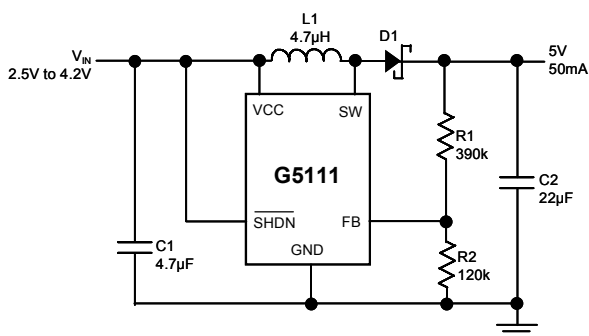

L1: MURATA LQH3C4R7M24
D1: MOTOROLA MBR0520

SEPIC Converter

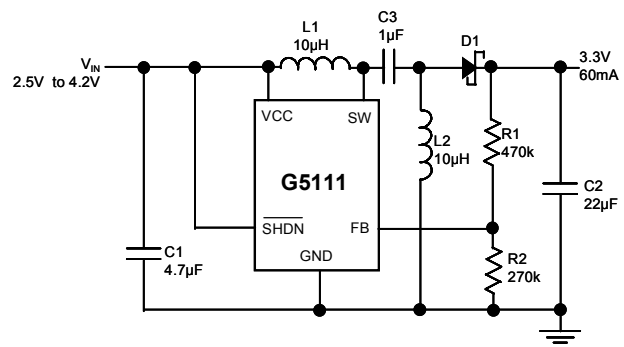

L1, L2: MURATA LQH3C100K24
D1: MOTOROLA MBR0520

White LED Driver

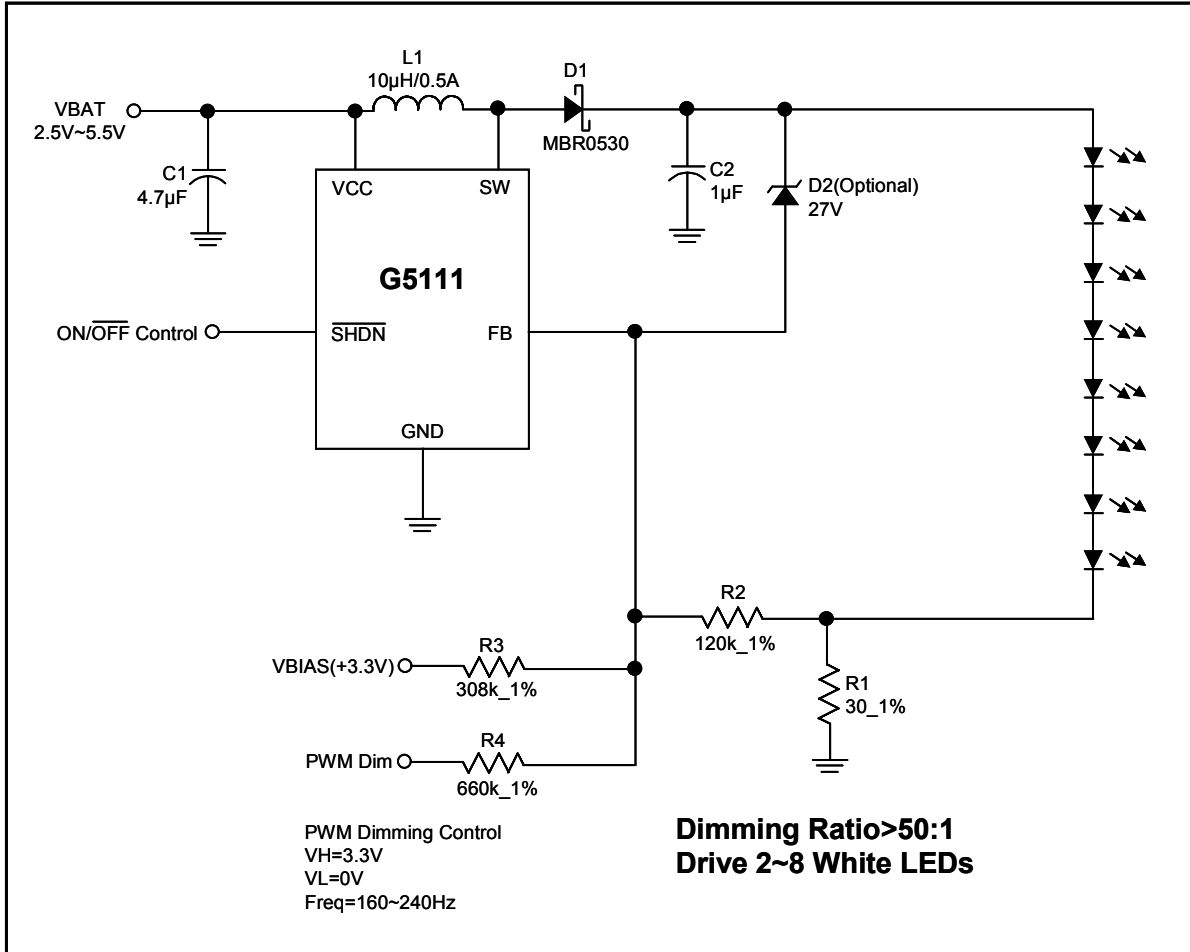

Package Information

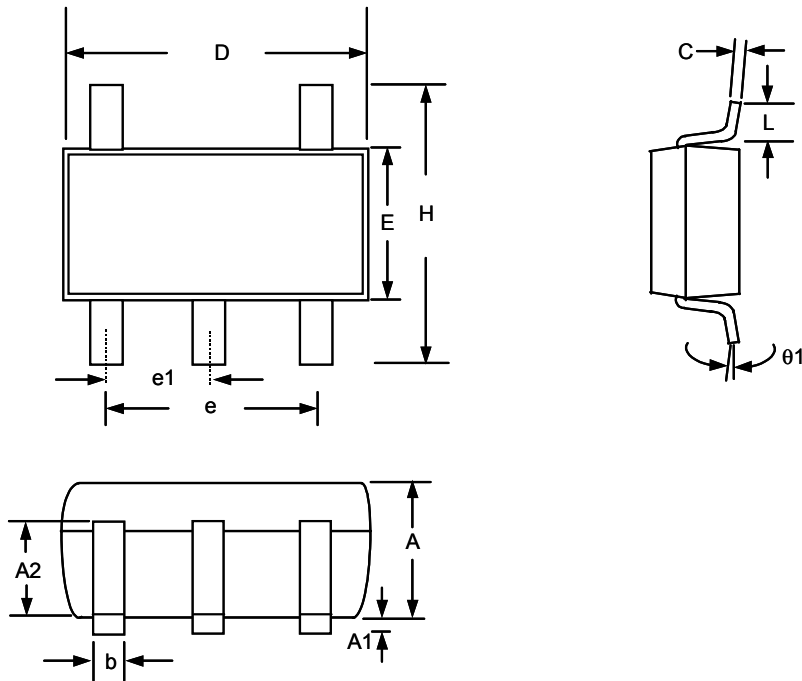

Note:

1. Package body sizes exclude mold flash protrusions or gate burrs
2. Tolerance ± 0.1000 mm (4mil) unless otherwise specified
3. Coplanarity: 0.1000mm
4. Dimension L is measured in gage plane

SYMBOLS	DIMENSIONS IN MILLIMETERS		
	MIN	NOM	MAX
A	1.00	1.10	1.30
A1	0.00	----	0.10
A2	0.70	0.80	0.90
b	0.35	0.40	0.50
C	0.10	0.15	0.25
D	2.70	2.90	3.10
E	1.40	1.60	1.80
e	----	1.90(TYP)	----
e1	----	0.95	----
H	2.60	2.80	3.00
L	0.37	----	----
$\theta 1$	1°	5°	9°

Taping Specification

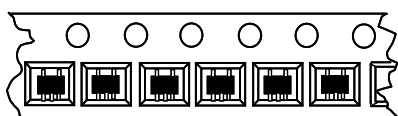

Feed Direction
SOT23-5 Package Orientation

GMT Inc. does not assume any responsibility for use of any circuitry described, no circuit patent licenses are implied and GMT Inc. reserves the right at any time without notice to change said circuitry and specifications.