



Dual USB High-Side Power Switch

Features

- Compliant to USB specifications
- Low MOSFET on resistance at 5.0V 140mΩ max. per channel
- 500mA minimum continuous load current per channel
- 3.0V to 5.5V input
- 110μA typical on-state supply current
- 1μA typical off-state supply current
- Output can be forced higher than input (off-state)
- 1.25A maximum current limit
- Thermal shutdown
- 2.4V typical undervoltage lockout (UVLO)
- Open-drain fault flag pins
- 1ms turn-on (soft-start) and fast turnoff
- Available with active-high or active-low enable

Applications

- USB host and self-powered hubs
- Bus-powered hubs
- Hot plug-in power supplies
- Battery-charger circuits

Description

The G526 is a dual integrated high-side power switch with independent enable and flag functions, optimized for self-powered and bus-powered Universal Serial Bus (USB) applications.

The G526 satisfies the following USB requirements: the switch's low on-resistance meets USB voltage drop requirements; fault current is limited to typically 750mA, well below the UL 25VA safety requirement; and flag outputs are available to indicate fault conditions to the local USB controller. Soft start eliminates the momentary voltage drop on the upstream port that may occur when the switch is enabled in bus-powered applications.

Additional features include thermal shutdown to prevent catastrophic switch failure from high-current loads, under-voltage lockout (UVLO) ensuring that the device remains off unless there is a valid input voltage present, and an enable input that is compatible with both 3.3V and 5V logic.

The G526 is available in active-high and active-low enable versions in 8-pin SOIC packages.

Ordering Information

PART	ENABLE	TEMP. RANGE	PACKAGE
G526-1	Active High	-40°C to +85°C	8-Pin SOP
G526-2	Active Low	-40°C to +85°C	8-Pin SOP

Pin Configuration

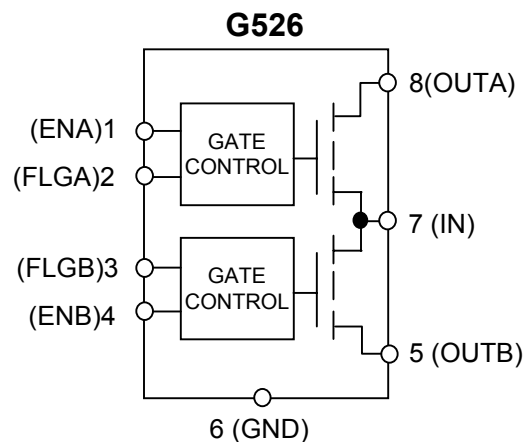
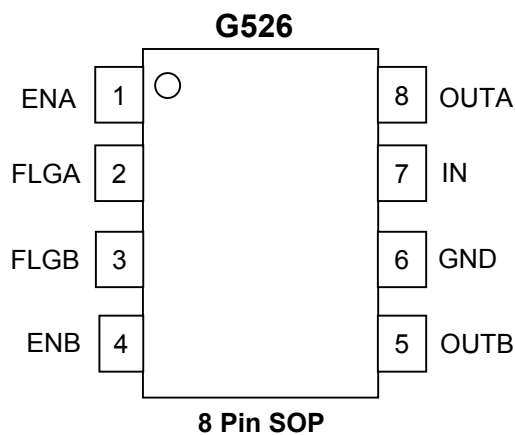

**Absolute Maximum Ratings**

Supply Voltage (VIN).....	+6.0V
Fault Flag Voltage (VFLG).....	+6.0V
Fault flag current (IFLG).....	50mA
Output Voltage (VOUT).....	+6.0V
Output Current (IOUT).....	Internally Limited
Control Input (VEN).....	-0.3V to 6V
Storage Temperature (TS).....	-65°C to +150°C
Lead Temperature (Soldering 5 sec.).....	260°C
ESD protection.....	1KV

Operating Ratings

Supply Voltage (VIN).....	+3V to +5.5V
Ambient Operating Temperature (TA)....	-40°C to +85°C
Thermal Resistance	
SOIC (θ JA).....	160°C/W

Electrical Characteristics ($V_{IN}=+5V$; $T_A=25^\circ C$; unless noted.)

PARAMETER	CONDITION	MIN	TYP	MAX	UNITS
Supply Current	Note *, switch off, OUT = open		25		μA
	Note *, switch on, OUT = open		110		μA
Enable Input Threshold	low to high transition		2.4	2.5	V
	high to low transition, Note *	1.0	2.2		V
Enable Input Current	$V_{EN} = V_{OH}(\min) = 2.4V$		0.01	1	μA
	$V_{EN} = V_{OL}(\max) = 0.8V$		0.01	1	μA
Enable Input Capacitance			1		pF
Switch Resistance	$V_{IN} = 5V$		100		m Ω
	$V_{IN} = 3V$		140		m Ω
Output Turn-On Delay	$R_L = 10\Omega$ each output		1		ms
Output Turn-On Rise Time	$R_L = 10\Omega$ each output		0.5		ms
Output Turn-Off Delay	$R_L = 10\Omega$ each output		1	20	μs
Output Turn-Off Fall Time	$R_L = 10\Omega$ each output		1	20	μs
Output Leakage Current	each output			10	μA
Short Circuit Current Limit	each output	0.5	0.75	1.25	A
Overtemperature shutdown Threshold	T_J increasing		135		$^\circ C$
	T_J decreasing		125		$^\circ C$
Error Flag Output Resistance	$V_{IN} = 5V, I_L = 10mA$		10		Ω
	$V_{IN} = 3.3V, I_L = 10mA$		15		Ω
Error Flag Off Current	$V_{FLAG} = 5V$		0.01	1	μA
UVLO Threshold	$V_{IN} =$ increasing		2.5		V
	$V_{IN} =$ decreasing		2.3		V

General Note: Devices are ESD protected, however, handling precautions recommended.

Note *: Off is ≤ 1.0 and on is $\geq 2.4V$ for the G526-1. Off is $\geq 2.4V$ and on is $\leq 1.0V$ for the G526-2. The enable input has approximately 200mV of hysteresis. See control threshold charts.

Pin Description

PIN NUMBER	PIN NAME	PIN FUNCTION
1/4	EN(A/B)	Enable (input): Logic-compatible enable input. High input $>2.1V$ typical. Low input $<1.9V$ typical (-1 active high, -2 active low). Do not float.
2/3	FLG(A/B)	Fault Flag (Output): Active-low, open-drain output. Indicates overcurrent, UVLO, and thermal shutdown.
6	GND	Ground: Supply return.
7	IN	Supply Input: Output MOSFET source. Also supplies IC's internal circuitry. Connect to positive supply.
8/5	OUT(A/B)	Switch Output: Output MOSFET drain. Typically connect to switched side of load.

Typical Applications

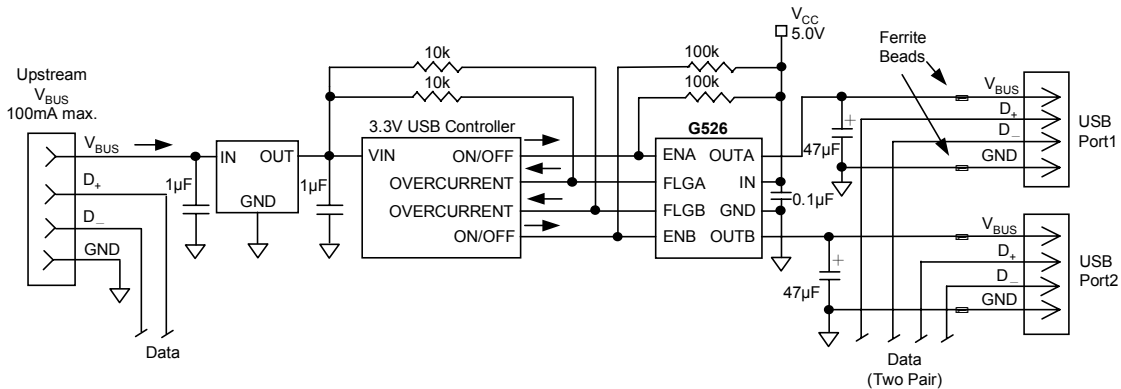

Block Diagrams

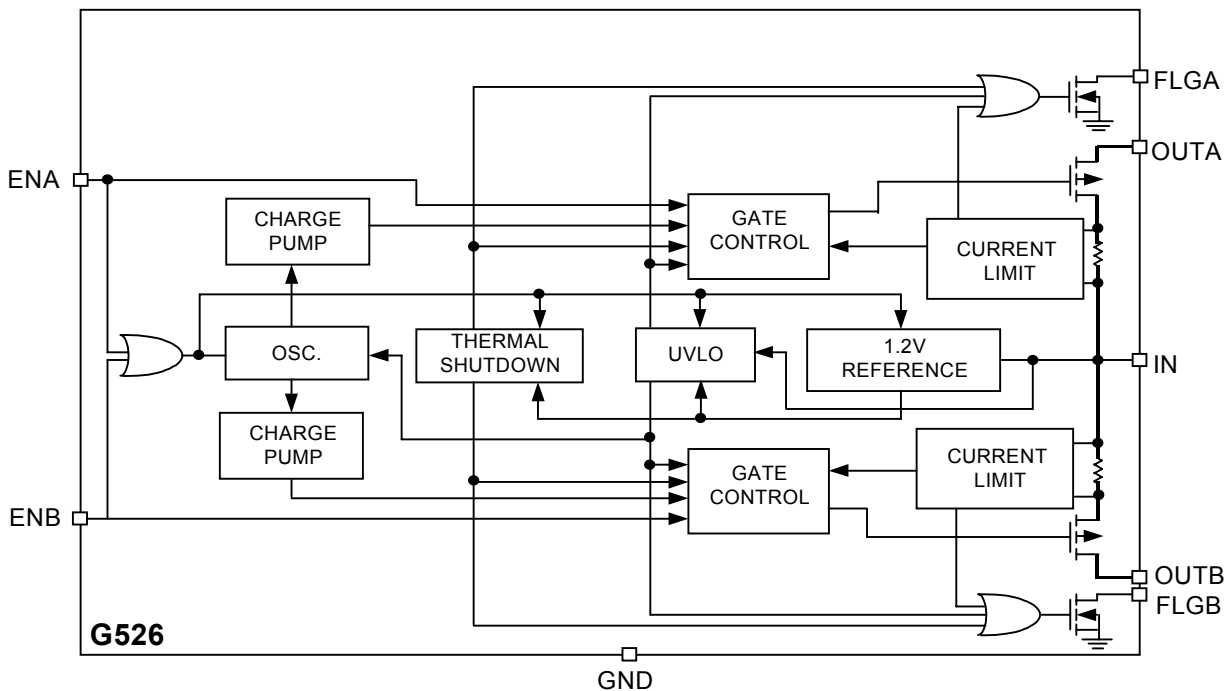

Functional Description

The G526-1 and G526-2 are dual high-side switches with active-high and active-low enable inputs, respectively. Fault conditions turn off or inhibit turn-on one or both of the output transistors, depending upon the type of fault, and activate the open-drain error flag transistors to pull FLG pin to ground.

Input and Output

IN (input) is the power supply connection to the logic circuitry and the source of the output MOSFET. OUTx (output) is the drain of the output A or B MOSFET. In a typical circuit, current flows through the switch from IN to OUT toward the load.

The output MOSFET and driver circuitry are also de-

signed to allow the MOSFET drain to be externally forced to a higher voltage than the source ($V_{OUT} > V_{IN}$) when the output is off. In this situation, the G526 avoids undesirable drain-to-body diode current flow by connecting the body to the most positive voltage. If $V_{OUT} > V_{IN}$ when switch is enabled, current will flow from V_{OUT} to V_{IN} .

Thermal Shutdown

Thermal shutdown shuts off both output MOSFETs and signals both fault flags if the die temperature exceeds 135°C. 10°C of hysteresis prevents the switch from turning on until the die temperature drops to 125°C. Overtemperature detection functions only when at least one switch is enabled.

Undervoltage Lockout

UVLO (undervoltage lockout) prevents the output MOSFET from turning on until IN (input voltage) exceeds 2.5V typical. After the switch turns on, if the voltage drops below 2.3V typical, UVLO shuts off the output MOSFET and signals the fault flag. Undervoltage detection functions only when at least one switch is enabled.

Current Sensing and Limiting

The current limit threshold is preset internally. The preset level prevents damage to the output MOSFET and external load but allows a minimum current of 0.5A through the output MOSFET.

A current sense circuit senses the output current of MOSFET switch. If output current exceeds the current limit threshold, the output MOSFET switch is shut off and a fault flag is pulled low. The reaction to an over-current is measured with the following scenarios:

Switch Enable into Heavy Load

If a switch is powered-on or enabled into a heavy load or short-circuit, the switch immediately goes into a constant-current mode, reducing output voltage. The fault flag goes low until the load is reduced or thermal shutdown occurs.

Heavy Load Applied Suddenly to Enabled Switch

When a heavy load is applied, a large current may flow from the output capacitor and the switch. The current limit circuit may shut the switch off briefly, then fold back into constant-current mode. In that case, the fault flag falls until the load is reduced.

Fault Flag

FLG is an N-channel, open-drain MOSFET output. The fault-flag is active (low) for one or more of the following conditions: undervoltage, current limit, or thermal shutdown. The flag output MOSFET is capable of sinking a 10mA load to typically 100mV above ground. Both flag pins may be "wire-NORed" to a common pullup resistor.

Applications Information

Supply filtering

A 0.1µF to 1µF bypass capacitor from IN to GND, located at the G526, is strongly recommended to control supply transients. Without a bypass capacitor, an output short may cause sufficient ringing on the input (from supply lead inductance) to damage internal control circuitry.

Input or output transients must not exceed the absolute maximum supply voltage (VIN max = 6V) even for a short duration.

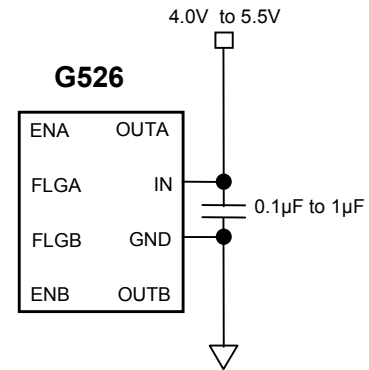

Figure 1. Supply Bypassing

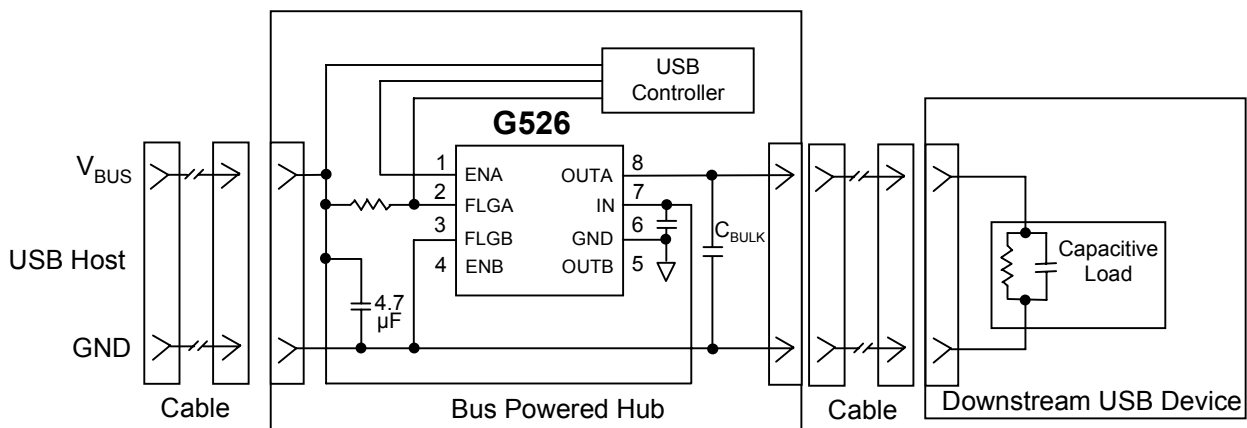

Figure 2. Soft Start (Single Channel)

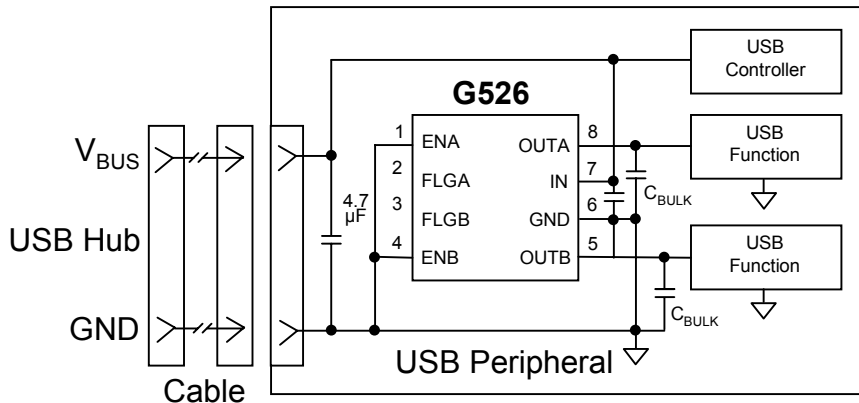

Figure 3. Inrush Current-Limit Application

Enable Input

EN must be driven logic high or logic low, or be pulled high or low for a clearly defined input. Floating the input may cause unpredictable operation. EN should not be allowed to go negative with respect to GND.

Soft Start

The G526 presents a high impedance when off, and slowly becomes a low impedance as it turns on. This reduces inrush current and related voltage drop that results from charging a capacitive load, satisfying the USB voltage drop requirements, for bus-powered applications as shown in Figure 2.

The soft start circuit shown in Figure 3 can be utilized to meet USB transient regulation specifications with large load capacitances ($C_{BULK} > 10\mu F$). The G526 will provide inrush current limiting for these applications.

Transient Overcurrent Filter

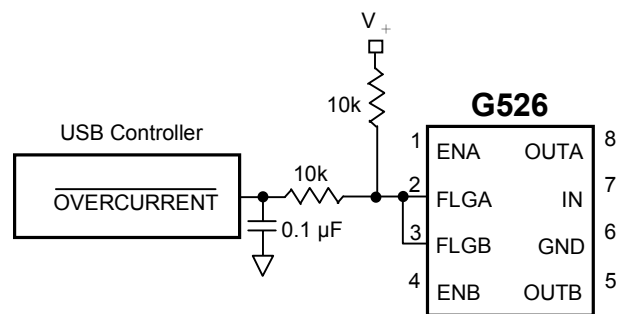
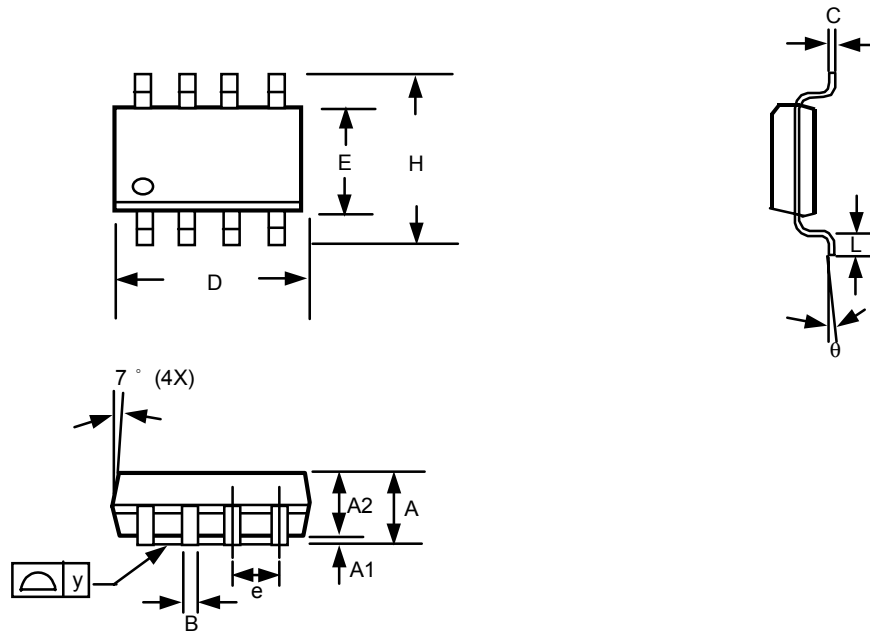

Figure 4. Transient Filter

The inrush current from the connection of a heavy capacitive load may cause the fault flag to fall for a short duration while the switch is in a constant-current mode, for charging the capacitance. In needed, a simple 1ms RC low-pass filter in series with the fault flag circuit will prevent erroneous overcurrent reporting (see Figure 4).

Package Information



Note:

1. Package body sizes exclude mold flash and gate burrs
2. Dimension L is measured in gage plane
3. Tolerance 0.10mm unless otherwise specified
4. Controlling dimension is millimeter converted inch dimensions are not necessarily exact.

SYMBOL	DIMENSION IN MM			DIMENSION IN INCH		
	MIN.	NOM.	MAX.	MIN.	NOM.	MAX.
A	1.35	1.60	1.75	0.053	0.063	0.069
A1	0.10	----	0.25	0.004	----	0.010
A2	----	1.45	----	----	0.057	----
B	0.33	----	0.51	0.013	----	0.020
C	0.19	----	0.25	0.007	----	0.010
D	4.80	----	5.00	0.189	----	0.197
E	3.80	----	4.00	0.150	----	0.157
e	----	1.27	----	----	0.050	----
H	5.80	----	6.20	0.228	----	0.244
L	0.40	----	1.27	0.016	----	0.050
y	----	----	0.10	----	----	0.004
θ	0°	----	8°	0°	----	8°

Taping Specification

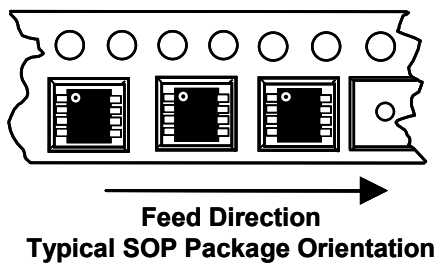

GMT Inc. does not assume any responsibility for use of any circuitry described, no circuit patent licenses are implied and GMT Inc. reserves the right at any time without notice to change said circuitry and specifications.