

4-Pin μ P Voltage Monitors with Manual Reset Input

Features

- Precision Monitoring of +3V, +3.3V, and +5V Power-Supply Voltages
- Fully Specified Over Temperature
- Available in Three Output Configurations
 - Push-Pull $\overline{\text{RESET}}$ Output (G692L)
 - Push-Pull RESET Output (G692H)
 - Open-Drain $\overline{\text{RESET}}$ Output (G693L)
- 140ms min Power-On Reset Pulse Width
- 5 μ A Supply Current
- Guaranteed Reset Valid to $V_{CC} = +1V$
- Power Supply Transient Immunity
- No External Components
- Manual Reset Input
- 4-Pin SOT143 Package

Applications

- Computers
- Controllers
- Intelligent Instruments
- Critical μ P and μ C Power Monitoring
- Portable / Battery-Powered Equipment
- Automotive

General Description

The G692/G693 are microprocessor (μ P) supervisory circuits used to monitor the power supplies in μ P and digital systems. They provide excellent circuit reliability and low cost by eliminating external components and adjustments when used with +5V, +3.3V, +3.0V- powered circuits. The G692/G693 also provide a de-bounced manual reset input.

These circuits perform a single function: they assert a reset signal whenever the V_{CC} supply voltage declines below a preset threshold, keeping it asserted for at least 140ms after V_{CC} has risen above the reset threshold. Reset thresholds suitable for operation with a variety of supply voltages are available.

The G693L has an open-drain output stage, while the G692 have push-pull outputs. The G693L's open-drain $\overline{\text{RESET}}$ output requires a pull-up resistor that can be connected to a voltage higher than V_{CC} . The G692L have an active-low $\overline{\text{RESET}}$ output, while the G692H has an active-high RESET output. The reset comparator is designed to ignore fast transients on V_{CC} , and the outputs are guaranteed to be in the correct logic state for V_{CC} down to 1V.

Low supply current makes the G692/G693 ideal for use in portable equipment. The G692/G693 are available in a 4-pin SOT143 packages.

Ordering Information

PART	TEMP. RANGE	PIN-PACKAGE
G692H(L)xxxTC	-40°C ~ +105°C	SOT143
G693LxxxTC	-40°C ~ +105°C	SOT143

* xxx specifies the threshold voltage.

e.g. 263 denotes the 2.63V threshold voltage.

Pin Configuration

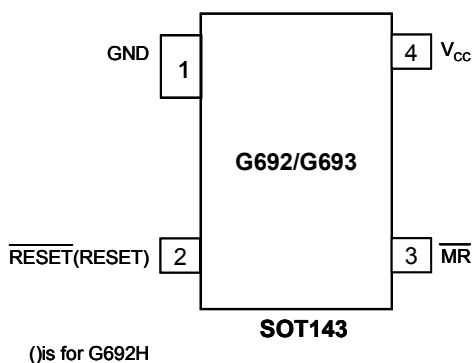

Typical Operating Circuit

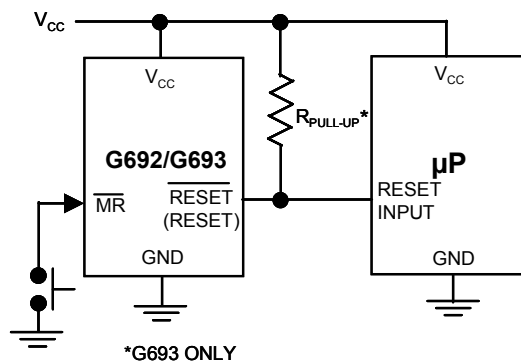



Absolute Maximum Ratings

Terminal Voltage (with respect to GND)
 V_{CC}-0.3V to +6.0V
 RESET, \overline{RESET} (push-pull).....-0.3V to ($V_{CC} + 0.3V$)
 \overline{RESET} (open drain).....-0.3V to +6.0V
 Input Current, V_{CC} 20mA
 Output Current, RESET, \overline{RESET} 20mA

Continuous Power Dissipation ($T_A = +70^\circ C$)
 SOT 143 (derate 4mW/ $^\circ C$ above +70 $^\circ C$).....320mW
 Operating Temperature Range-40 $^\circ C$ to +105 $^\circ C$
 Storage Temperature Range.....-65 $^\circ C$ to +150 $^\circ C$
 Lead Temperature (soldering, 10s)+300 $^\circ C$

Stresses beyond those listed under “Absolute Maximum Ratings” may cause p’ermanent damage to the device. These are stress ratings only, and functional operation of the device at these or any other conditions beyond those indicated in the operational sections of the specifications is not implied. Exposure to absolute maximum rating conditions for extended periods may affect device reliability.

Electrical Characteristics

(V_{CC} = full range, $T_A = -40^\circ C$ to +105 $^\circ C$, unless otherwise noted. Typical values are at $T_A = +25^\circ C$, $V_{CC} = 5V$ for 463/438/400 versions, $V_{CC} = 3.3V$ for 308/293 versions, and $V_{CC} = 3V$ for 263 version.) (Note 1)

PARAMETER	SYMBOL	CONDITION	MIN	TYP	MAX	UNITS	
V _{CC} Range		T _A = 0 $^\circ C$ +70 $^\circ C$	1.0		5.5	V	
		T _A = -40 $^\circ C$ +105 $^\circ C$	1.2		5.5		
Supply Current	I _{CC}	T _A = -40 $^\circ C$ +105 $^\circ C$	V _{CC} <5.5V, G69_ _463/438/400_	5.5	9	μA	
			V _{CC} <3.6V, G69_ _308/293/263_	5	8		
Reset Threshold	V _{TH}	G69_ 463	T _A = +25 $^\circ C$	4.537	4.63	4.722	V
		G69_ 438	T _A = +25 $^\circ C$	4.292	4.38	4.467	
		G69_ 400	T _A = +25 $^\circ C$	3.92	4.00	4.08	
		G69_ 308	T _A = +25 $^\circ C$	3.018	3.08	3.141	
		G69_ 293	T _A = +25 $^\circ C$	2.871	2.93	2.988	
		G69_ 263	T _A = +25 $^\circ C$	2.577	2.63	2.682	

**Electrical Characteristics (Continued)**

(V_{CC} = full range, T_A = -40°C to $+105^{\circ}\text{C}$, unless otherwise noted. Typical values are at T_A = $+25^{\circ}\text{C}$, V_{CC} = 5V for 463/438/400 versions, V_{CC} = 3.3V for 308/293 versions, and V_{CC} = 3V for 263 version.) (Note 1)

PARAMETER	SYMBOL	CONDITION	MIN	TYP	MAX	UNITS
Reset Threshold Tempco				70		ppm/ $^{\circ}\text{C}$
V_{CC} to Reset Delay (Note 2)		$V_{CC} = V_{TH}$ to $(V_{TH} - 100\text{mV})$		15		
Reset Active Timeout Period		$V_{CC} = V_{TH}$ max, G69__ 463/438/400	250	510	720	ms
		$V_{CC} = V_{TH}$ max, G69__ 308/293/263	140	310	520	
$\overline{\text{MR}}$ Minima Pulse Width	t_{MR}			10		μs
$\overline{\text{MR}}$ Glitch Immunity (Note 3)				100		ns
$\overline{\text{MR}}$ to Reset Propagation Delay (Note 2)	t_{MD}			0.5		μs
$\overline{\text{MR}}$ Input Threshold	V_{IH}	$V_{CC} > V_{TH(\text{max})}$	0.6 x V_{CC}			V
	V_{IL}				0.25 x V_{CC}	
$\overline{\text{MR}}$ Pull-up Resistance			10	20	30	K Ω
RESET Output Current Low (push-pull active low, and open-drain active-low, G692L and G693L)	I_{OL}	$V_{CC} = 2.5\text{V}$, $V_{\overline{\text{RESET}}} = 0.5\text{V}$	8			mA
RESET Output Current High (push-pull active low, G692L)	I_{OH}	$V_{CC} = 5\text{V}$, $V_{\overline{\text{RESET}}} = 4.5\text{V}$, G692L463/438/400	4.5			mA
		$V_{CC} = 3.3\text{V}$, $V_{\overline{\text{RESET}}} = 2.8\text{V}$, G692L308/293	3			
		$V_{CC} = 3\text{V}$, $V_{\overline{\text{RESET}}} = 2.5\text{V}$, G692L263	2			
RESET Output Current Low (push-pull active high, G692H)	I_{OL}	$V_{CC} = 5\text{V}$, $V_{\overline{\text{RESET}}} = 0.5\text{V}$, G692H463/438/400	16			mA
		$V_{CC} = 3.3\text{V}$, $V_{\overline{\text{RESET}}} = 0.5\text{V}$, G692H308/293	12			
		$V_{CC} = 3\text{V}$, $V_{\overline{\text{RESET}}} = 0.5\text{V}$, G692H263	10			
RESET Output Current High (push-pull active high, G692H)	I_{OH}	$V_{CC} = 2.5\text{V}$, $V_{\overline{\text{RESET}}} = 2\text{V}$	2			mA
RESET Open-Drain Output Leakage Current (G693L)		$V_{CC} > V_{TH}$, $\overline{\text{RESET}}$ deasserted			1	μA

Note 1: Production testing done at T_A = $+25^{\circ}\text{C}$; limits over temperature guaranteed by design.

Note 2: $\overline{\text{RESET}}$ output is for G692L/G693L; While RESET output is for G692H.

Note 3: "Glitches" of 100ns or less typically will not generate a reset pulse.

Selector Guide

PART/SUFFIX	RESET THRESHOLD (V)	OUTPUT TYPE	TOP MARK
G693L463T_	4.63	Open-Drain $\overline{\text{RESET}}$	693Fx
G693L438T_	4.38	Open-Drain $\overline{\text{RESET}}$	693Ex
G693L400T_	4.00	Open-Drain $\overline{\text{RESET}}$	693Dx
G693L308T_	3.08	Open-Drain $\overline{\text{RESET}}$	693Cx
G693L293T_	2.93	Open-Drain $\overline{\text{RESET}}$	693Bx
G693L263T_	2.63	Open-Drain $\overline{\text{RESET}}$	693Ax
G692H463T_	4.63	Push-Pull RESET	692Lx
G692H438T_	4.38	Push-Pull RESET	692Kx
G692H400T_	4.00	Push-Pull RESET	692Jx
G692H308T_	3.08	Push-Pull RESET	692Ix
G692H293T_	2.93	Push-Pull RESET	692Hx
G692H263T_	2.63	Push-Pull RESET	692Gx
G692L463T_	4.63	Push-Pull $\overline{\text{RESET}}$	692Fx
G692L438T_	4.38	Push-Pull $\overline{\text{RESET}}$	692Ex
G692L400T_	4.00	Push-Pull $\overline{\text{RESET}}$	692Dx
G692L308T_	3.08	Push-Pull $\overline{\text{RESET}}$	692Cx
G692L293T_	2.93	Push-Pull $\overline{\text{RESET}}$	692Bx
G692L263T_	2.63	Push-Pull $\overline{\text{RESET}}$	692Ax



Typical Operating Characteristics

(V_{CC} = full range, T_A = -40°C to $+105^{\circ}\text{C}$, unless otherwise noted. Typical values are at T_A = $+25^{\circ}\text{C}$, V_{CC} = 5V for 463/438/400 versions, V_{CC} = 3.3V for 308/293 versions, and V_{CC} = 3V for 263 version.)

Supply Current vs. Temperature (No Load)

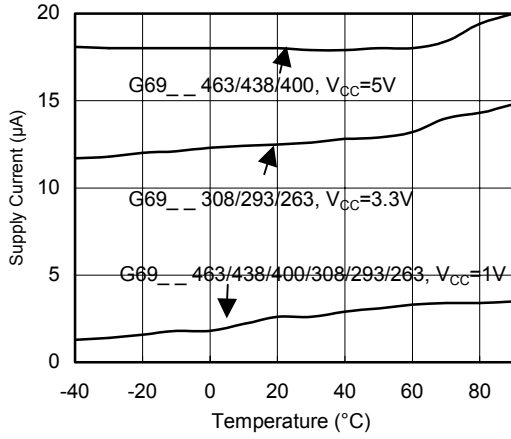

Power-down Reset Delay vs. Temperature (G69_ 308/293/263)

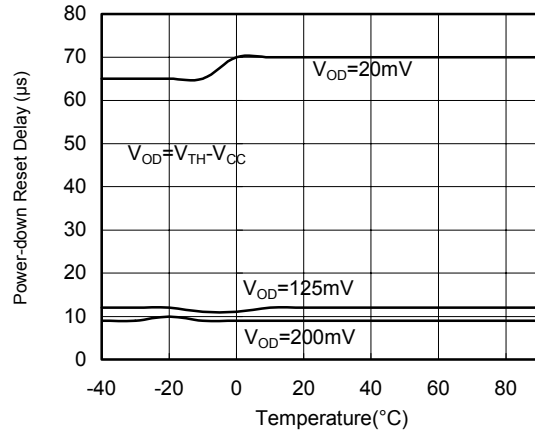

Power-up Reset Timeout vs. Temperature

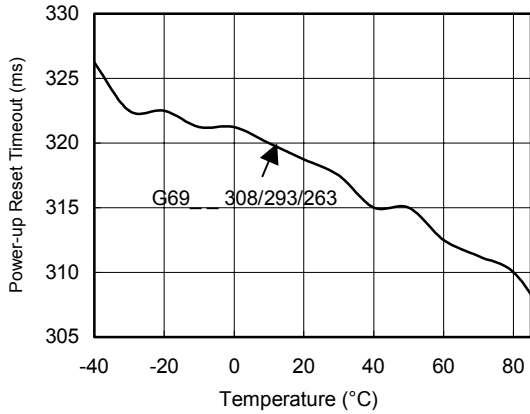

Normalized Reset Threshold vs. Temperature

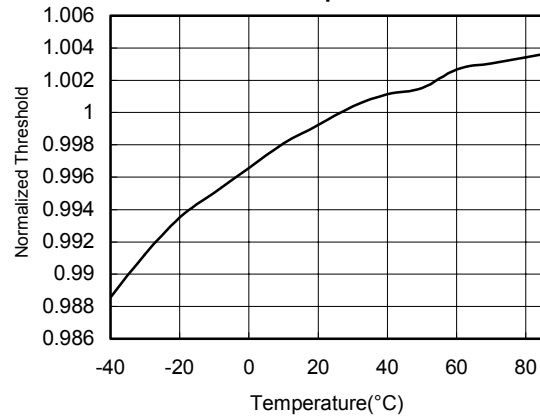

Pin Description

PIN	NAME	FUNCTION
1	GND	Ground
2	RESET (G693L/G692L)	RESET Output remains low while V_{CC} is below the reset threshold, and for at least 140ms after V_{CC} rises above the reset threshold.
	RESET (G692H)	RESET Output remains high while V_{CC} is below the reset threshold, and for at least 140ms after V_{CC} rises above the reset threshold.
3	\overline{MR}	Manual Reset Input. A logic low on \overline{MR} asserts reset. Reset remains asserted as long as \overline{MR} is low and for at least 140ms after \overline{MR} returns high. This active-low input has an internal 20k Ω pull-up resistor. It can be driven from a TTL or CMOS-logic line, or shorted to ground with a switch. Leave open if unused.
4	V_{CC}	Supply Voltage (+5V, +3.3V, +3.0V)

Detailed Description

A microprocessor's (μP 's) reset input starts the μP in a known state. The G693L/G692L/G692H assert reset to prevent code-execution errors during power-up, power-down, or brownout conditions. They assert a reset signal whenever the V_{CC} supply voltage declines below a preset threshold, keeping it asserted for at least 140ms after V_{CC} has risen above the reset threshold. The G693L uses an open-drain output, and the G692L/G692H have a push-pull output stage. Connect a pull-up resistor on the G693L's RESET output to any supply between 0 and 5.5V.

The manual reset input (\overline{MR}) can also initiate a reset. See the Manual Reset Input Section.

Manual Reset Input

Many μP -based products require manual reset capability, allowing the operator, a test technician, or external logic circuitry to initiate a reset. A logic low on \overline{MR} asserts reset. Reset remains asserted while \overline{MR} is low, and for the Reset Active Timeout Period (t_{RP}) after \overline{MR} returns high. This input has an internal 20k Ω pull-up resistor, so it can be left open if it is not used. \overline{MR} can be driven with TTL or CMOS-logic levels, or with open-drain / collector outputs. Connect a normally open momentary switch from \overline{MR} to GND to create a manual-reset function; external debounce circuitry is not required. If \overline{MR} is driven from long cables or if the device is used in a noisy environment, connecting a 0.1 μF capacitor from \overline{MR} to ground provides additional noise immunity.

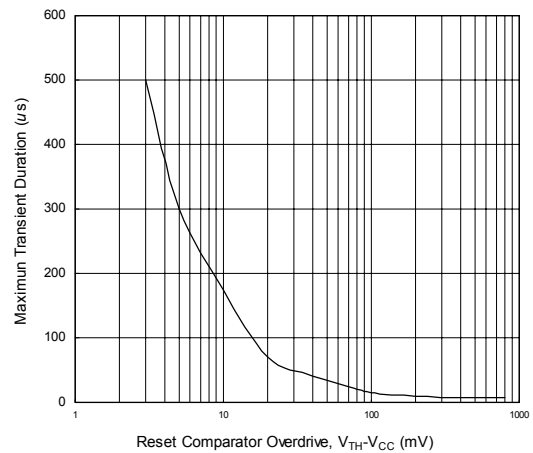

Figure 1. Maximum Transient Duration Without Causing a Reset Pulse vs. Reset Comparator Overdrive

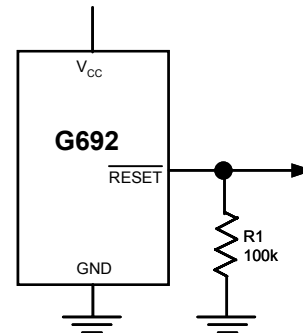

Figure 2. \overline{RESET} Valid to $V_{CC} = \text{Ground}$ Circuit

Applications Information

Negative-Going V_{CC} Transients

In addition to issuing a reset to the μP during power-up, power-down, and brownout conditions, the G693L/G692H/G692L are relatively immune to short-duration negative-going V_{CC} transients (glitches).

Figure 1 shows typical transient duration vs. reset comparator overdrive, for which the G693L/G692H/G692L do not generate a reset pulse. The graph was generated using a negative-going pulse applied to V_{CC} , starting 0.5V above the actual reset threshold and ending below it by the magnitude indicated (reset comparator overdrive). The graph indicates the maximum pulse width a negative-going V_{CC} transient can have without causing a reset pulse. As the magnitude of the transient increases (goes farther below the reset threshold), the maximum allowable pulse width decreases. Typically, for the G69_463 and G69_438, a V_{CC} transient that goes 100mV below the reset threshold and lasts 15 μs or less will not cause a reset pulse. A 0.1 μF bypass capacitor mounted as close as possible to the V_{CC} pin provides additional transient immunity.

Ensuring a Valid Reset Output Down to $V_{CC} = 0$

When V_{CC} falls below 1V, the G692 \overline{RESET} output no longer sinks current—it becomes an open circuit. Therefore, high-impedance CMOS logic inputs connected to \overline{RESET} can drift to undetermined voltages. This presents no problem in most applications since most μP and other circuitry is inoperative with V_{CC} below 1V. However, in applications where \overline{RESET} must be valid down to 0V, adding a pull-down resistor to \overline{RESET} causes any stray leakage currents to flow to ground, holding \overline{RESET} low (Figure 2). R1's value is not critical; 100k Ω is large enough not to load \overline{RESET} and small enough to pull \overline{RESET} to ground.

A 100k Ω pull-up resistor to V_{CC} is also recommended for the G693L if \overline{RESET} is required to remain valid for $V_{CC} < 1V$.

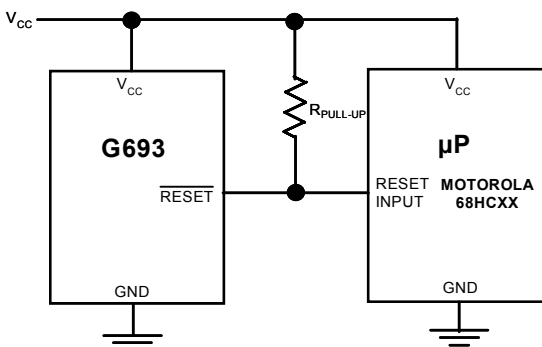

Figure 3. Interfacing to μP s with Bidirectional Reset I/O

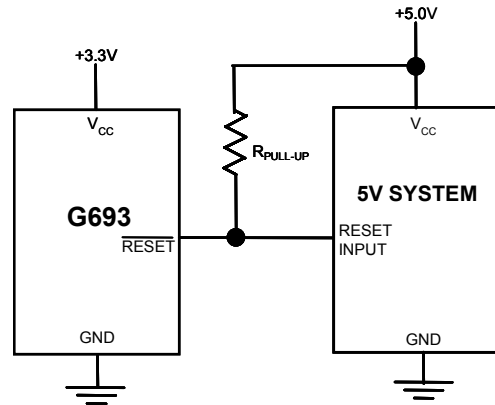

Figure 4. G693L Open-Drain \overline{RESET} Output Allows Use with Multiple Supplies

Interfacing to μP s with Bidirectional Reset Pins

Since the \overline{RESET} output on the G693L is open drain, this device interfaces easily with μP s that have bidirectional reset pins, such as the Motorola 68HC11. Connecting the μP supervisor's \overline{RESET} output directly to the microcontroller's (μC 's) \overline{RESET} pin with a single pull-up resistor allows either device to assert reset (Figure 3).

G693L Open-Drain \overline{RESET} Output Allows Use with Multiple Supplies

Generally, the pull-up connected to the G693L will connect to the supply voltage that is being monitored at the IC's V_{CC} pin. However, some systems may use the open-drain output to level-shift from the monitored supply to reset circuitry powered by some other supply (Figure 4). Note that as the G693L's V_{CC} decreases below 1V, so does the IC's ability to sink current at \overline{RESET} . Also, with any pull-up, \overline{RESET} will be pulled high as V_{CC} decays toward 0. The voltage where this occurs depends on the pull-up resistor value and the voltage to which it is connected.

Benefits of Highly Accurate Reset Threshold

Most μP supervisor ICs have reset threshold voltages between 5% and 10% below the value of nominal supply voltages. This ensures a reset will not occur within 5% of the nominal supply, but will occur when the supply is 10% below nominal.

When using ICs rated at only the nominal supply $\pm 5\%$, this leaves a zone of uncertainty where the supply is between 5% and 10% low, and where the reset may or may not be asserted.

The G69_463/G69_308 use highly accurate circuitry to ensure that reset is asserted close to the 5% limit, and long before the supply has declined to 10% below nominal.

Package Information

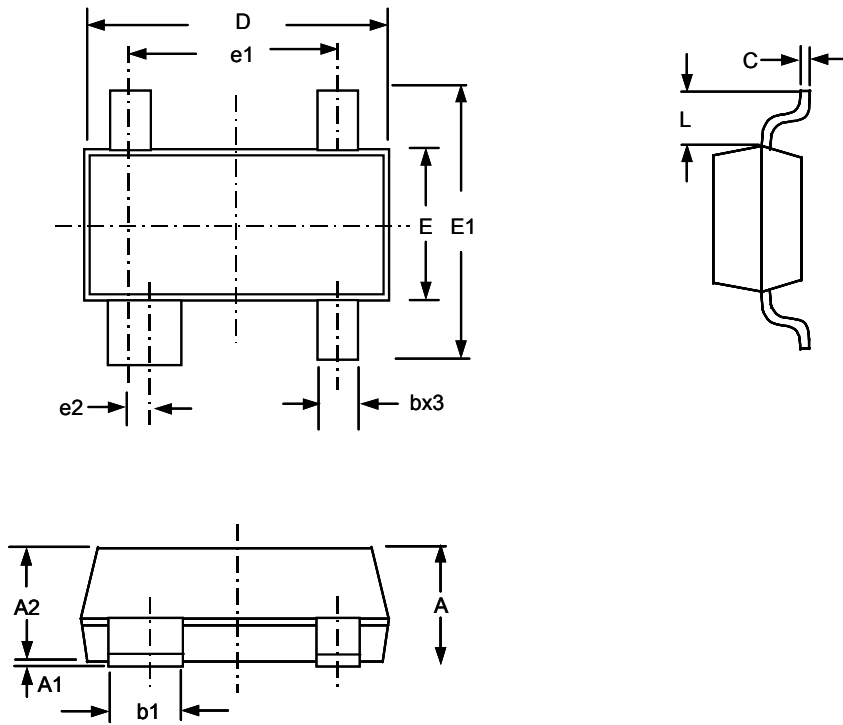

SOT 143 Package

SYMBOL	DIMENSION IN MILLIMETERS		DIMENSION IN INCHS	
	MIN.	MAX.	MIN.	MAX.
A	0.95	1.20	0.037	0.047
A1	0.05	0.10	0.002	0.004
A2	0.90	1.10	0.035	0.043
b	0.37	0.46	0.145	0.018
b1	0.76	0.89	0.030	0.035
C	0.10	0.18	0.004	0.007
D	2.80	3.04	0.110	0.120
E	1.20	1.40	0.047	0.055
E1	2.30	2.50	0.091	0.098
e1	1.92 BSC.		0.75 BSC.	
e2	0.20 BSC.		0.078 BSC.	
L	0.69 REF.		0.27 REF.	

Package Orientation

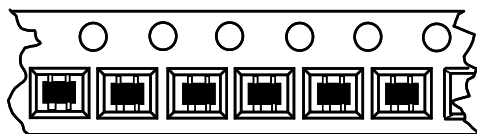

Feed Direction
SOT 143 Package Orientation

GMT Inc. does not assume any responsibility for use of any circuitry described, no circuit patent licenses are implied and GMT Inc. reserves the right at any time without notice to change said circuitry and specifications.